

# Intel<sup>®</sup> Carrier Grade Server T1GH2U

Technical Product Specification

---

*April 2008*

Rev 1.2



INFORMATION IN THIS DOCUMENT IS PROVIDED IN CONNECTION WITH INTEL® PRODUCTS. NO LICENSE, EXPRESS OR IMPLIED, BY ESTOPPEL OR OTHERWISE, TO ANY INTELLECTUAL PROPERTY RIGHTS IS GRANTED BY THIS DOCUMENT. EXCEPT AS PROVIDED IN INTEL'S TERMS AND CONDITIONS OF SALE FOR SUCH PRODUCTS, INTEL ASSUMES NO LIABILITY WHATSOEVER, AND INTEL DISCLAIMS ANY EXPRESS OR IMPLIED WARRANTY, RELATING TO SALE AND/OR USE OF INTEL PRODUCTS INCLUDING LIABILITY OR WARRANTIES RELATING TO FITNESS FOR A PARTICULAR PURPOSE, MERCHANTABILITY, OR INFRINGEMENT OF ANY PATENT, COPYRIGHT OR OTHER INTELLECTUAL PROPERTY RIGHT. Intel products are not intended for use in medical, life saving, life sustaining, critical control or safety systems, or in nuclear facility applications.

Intel may make changes to specifications and product descriptions at any time, without notice.

Intel Corporation may have patents or pending patent applications, trademarks, copyrights, or other intellectual property rights that relate to the presented subject matter. The furnishing of documents and other materials and information does not provide any license, express or implied, by estoppel or otherwise, to any such patents, trademarks, copyrights, or other intellectual property rights.

Designers must not rely on the absence or characteristics of any features or instructions marked "reserved" or "undefined." Intel reserves these for future definition and shall have no responsibility whatsoever for conflicts or incompatibilities arising from future changes to them.

Intel processor numbers are not a measure of performance. Processor numbers differentiate features within each processor family, not across different processor families. See [http://www.intel.com/products/processor\\_number](http://www.intel.com/products/processor_number) for details.

The Intel® Carrier Grade Server TIGH2U may contain design defects or errors known as errata which may cause the product to deviate from published specifications. Current characterized errata are available on request.

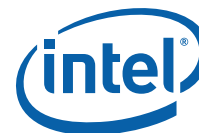
Contact your local Intel sales office or your distributor to obtain the latest specifications and before placing your product order.

Copies of documents which have an order number and are referenced in this document, or other Intel literature may be obtained by calling 1-800-548-4725 or by visiting Intel's website at <http://www.intel.com>.

BunnyPeople, Celeron, Celeron Inside, Centrino, Centrino logo, Core Inside, FlashFile, i960, InstantIP, Intel, Intel logo, Intel386, Intel486, Intel740, IntelDX2, IntelDX4, IntelSX2, Intel Core, Intel Inside, Intel Inside logo, Intel Leap ahead., Intel Leap ahead. logo, Intel NetBurst, Intel NetMerge, Intel NetStructure, Intel SingleDriver, Intel SpeedStep, Intel StrataFlash, Intel Viiv, Intel vPro, Intel XScale, Itanium, Itanium Inside, MCS, MMX, Oplus, OverDrive, PDCharm, Pentium, Pentium Inside, skool, Sound Mark, The Journey Inside, VTune, Xeon, and Xeon Inside are trademarks of Intel Corporation in the U.S. and other countries.

\*Other names and brands may be claimed as the property of others.

Copyright © 2008, Intel Corporation. All Rights Reserved.



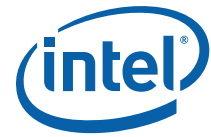
# Contents

---

- 1.0 Introduction** ..... 10
  - 1.1 Document Structure and Outline ..... 10
  - 1.2 Related Information..... 11
- 2.0 System Overview**..... 12
  - 2.1 Product Overview ..... 12
    - 2.1.1 Features ..... 14
  - 2.2 External Chassis Features..... 17
    - 2.2.1 TIGH2U System Front Views ..... 17
    - 2.2.2 Front Panel Features..... 18
    - 2.2.3 Hard Drives and Optical Drive ..... 19
      - 2.2.3.1 Hard Drive Tray Assembly..... 20
      - 2.2.3.2 Optical Drive ..... 21
    - 2.2.4 TIGH2U System Chassis Rear Panel ..... 22
  - 2.3 Internal Chassis Features ..... 22
    - 2.3.1 Intel® Server Board T5000PAL..... 22
    - 2.3.2 PCI/PCI Express Subsystem..... 23
    - 2.3.3 Power Subsystem..... 24
    - 2.3.4 Cooling Subsystem ..... 25
      - 2.3.4.1 CPU 1 and Memory Cooling Area ..... 26
      - 2.3.4.2 CPU 2 and Chipset Cooling Area..... 26
      - 2.3.4.3 PCI Cooling Area..... 26
      - 2.3.4.4 Hard Disk Drive and Power Supply Cooling ..... 26
      - 2.3.4.5 Fan Speed Control ..... 26
      - 2.3.4.6 Cooling Summary ..... 27
  - 2.4 Server Management ..... 27
  - 2.5 Specifications ..... 29
    - 2.5.1 Environmental Specifications ..... 29
    - 2.5.2 Physical Specifications ..... 30
- 3.0 Cables and Connectors** ..... 31
  - 3.1 System Interconnect Block Diagram ..... 31
  - 3.2 Cable and System Interconnect Descriptions..... 32
    - 3.2.1 Flex Circuit ..... 33
    - 3.2.2 IDE Signal Cable ..... 34
    - 3.2.3 SAS Backplane Power Cable..... 36
    - 3.2.4 TAM Board Signal Cable ..... 36
    - 3.2.5 Telco Alarms Signal Cable..... 38
    - 3.2.6 Intel® Z-U130 Value Solid State Drive Signal and Power Cable ..... 39
    - 3.2.7 SAS RAID Battery Power Cable..... 39
    - 3.2.8 Front Panel Serial Port Cable..... 40
  - 3.3 User-Accessible Interconnects ..... 41
    - 3.3.1 Keyboard and Mouse Ports ..... 41
    - 3.3.2 Serial Port B ..... 42
    - 3.3.3 Video Port ..... 43
    - 3.3.4 Universal Serial Bus (USB) Interface ..... 44
    - 3.3.5 Ethernet Connectors ..... 44
    - 3.3.6 External SAS 4X Hard Disk Drive Connector ..... 45
    - 3.3.7 AC Power Input for AC-Input Power Supply..... 46
    - 3.3.8 DC Power Input for DC-Input Power Supply ..... 46
    - 3.3.9 Alarms Connector..... 47



- 4.0 SAS Front Panel (SFP) Board ..... 48
  - 4.1 Features ..... 48
  - 4.2 Overview ..... 49
  - 4.3 Component Location ..... 50
  - 4.4 Power Distribution ..... 52
    - 4.4.1 Battery Backup Power Control ..... 52
    - 4.4.2 12 V to 1.8 V VRM ..... 53
    - 4.4.3 12 V to 1.5 V VRM ..... 53
    - 4.4.4 3.3 V to 1.35 V DC-to-DC Linear Converter ..... 53
    - 4.4.5 1.8 V to 1.2 V DC-to-DC Linear Converter ..... 53
  - 4.5 I/O Processor Subsystem ..... 53
    - 4.5.1 PCI-X to PCI Express Bridge ..... 53
    - 4.5.2 RAID Controller ..... 54
    - 4.5.3 Intel® 80333 I/O Processor ..... 54
    - 4.5.4 Flash Memory ..... 55
    - 4.5.5 NVRAM ..... 55
    - 4.5.6 PCI-X Buses ..... 55
    - 4.5.7 PCI Express Bus ..... 55
    - 4.5.8 DDR2 Bus ..... 55
    - 4.5.9 Intel® RAID Smart Battery ..... 55
    - 4.5.10 GPIOs ..... 56
    - 4.5.11 Intel® RAID Activation Key ..... 56
    - 4.5.12 I<sup>2</sup>C ..... 56
  - 4.6 SAS Controller (LSISAS1068) ..... 56
    - 4.6.1 PCI-X Interface ..... 57
    - 4.6.2 SAS Interface ..... 57
    - 4.6.3 Flash Memory ..... 57
    - 4.6.4 I<sup>2</sup>C ..... 57
    - 4.6.5 Indicator Buzzer ..... 57
  - 4.7 Clock Generation / Distribution ..... 57
    - 4.7.1 75 MHz Sourced Clock ..... 58
    - 4.7.2 133 MHz Sourced Clock ..... 58
    - 4.7.3 200 MHz Sourced Clock ..... 58
    - 4.7.4 100 MHz Sourced Clock ..... 58
    - 4.7.5 PLD Sourced Clock ..... 58
  - 4.8 Programmable Logic Device (PLD) ..... 59
    - 4.8.1 Power-on / Reset ..... 59
    - 4.8.2 Buzzer Control ..... 59
    - 4.8.3 Intel® RAID Smart Battery Control ..... 59
  - 4.9 Hardware RAID ..... 59
    - 4.9.1 Description ..... 59
    - 4.9.2 DDR-2 Support ..... 60
    - 4.9.3 Intel® 80333 I/O Processor NVRAM ..... 60
    - 4.9.4 ROMB Battery Backup ..... 60
  - 4.10 Software RAID ..... 60
    - 4.10.1 80333 Processor in Software RAID ..... 60
    - 4.10.2 LSISAS1068 in Software RAID ..... 60
  - 4.11 Debug Features ..... 61
    - 4.11.1 UART ..... 61
  - 4.12 Power Good Circuit ..... 61
    - 4.12.1 Power Good Outputs ..... 61
    - 4.12.2 Power Good Inputs ..... 61
  - 4.13 Reset Control ..... 61
  - 4.14 Connector Information ..... 62
    - 4.14.1 Baseboard Bridge Connector (J2C1) ..... 62



4.14.2	Intel® RAID Smart Battery Connector (J8B2) .....	65
4.14.3	DDR2 DIMM Connector (J6D1) .....	65
4.14.4	SAS Flex Connector (J2B1) .....	67
4.14.5	Serial Cable Header from Server Board (J8B1) .....	68
4.14.6	Power Connectors .....	69
4.14.7	External USB / Serial (J8E1) .....	69
4.14.8	80333 Processor UART Connector (J3B1) .....	70
4.14.9	Fan Connectors .....	70
4.14.10	Intel® Z-U130 Value Solid State Drive Connector .....	72
<b>5.0</b>	<b>SAS Backplane</b> .....	<b>73</b>
5.1	Overview .....	73
5.2	SFP Board Interface .....	74
5.3	SAS HDD Interface .....	76
5.4	IDE CD ROM / DVD to Server Board Interface .....	76
5.5	IDE CD-ROM / DVD-ROM Drive Interface .....	77
5.6	Power Connector Interface to Front Panel .....	78
<b>6.0</b>	<b>TAM Board</b> .....	<b>79</b>
6.1	Features .....	79
6.2	Overview .....	79
6.2.1	Front Panel Switches .....	80
6.2.2	Front Panel LEDs .....	81
6.2.2.1	System Status LEDs .....	81
6.2.2.2	System Fault LEDs .....	82
6.2.3	System Fault Relays .....	82
6.3	Connector Information .....	82
6.3.1	SFP Interface Connector .....	82
6.3.2	Alarms Connector .....	83
<b>7.0</b>	<b>Intel® Z-U130 Value Solid State Drive</b> .....	<b>85</b>
7.1	Functional Description .....	85
7.2	SFP Board Connector .....	87
7.3	Architecture .....	87
7.4	Installation .....	87
<b>8.0</b>	<b>PCI Riser Cards</b> .....	<b>88</b>
8.1	PCI-X and PCIe Add-in Card Options .....	90
8.2	PCI Express Riser Card Mechanical Specifications .....	90
<b>9.0</b>	<b>Power Subsystem</b> .....	<b>93</b>
9.1	Features .....	93
9.2	Power Supply Cage .....	93
9.2.1	Power Supply Cage Mechanical Specification .....	94
9.2.2	Power Supply Cage System Interface .....	95
9.2.3	P1 Server Board Power Connector .....	96
9.2.4	P2 Processor Power Connector .....	96
9.2.5	P3 Power Signal Cable .....	97
9.2.6	P4 SFP Board Power Connector .....	97
9.2.7	P5 SFP Board Power Connector .....	97
9.2.8	Output Current Requirements .....	98
9.2.9	Hot Swapping Power Modules .....	98
9.2.10	Intelligent Cage Functions .....	98
9.2.11	FRU Data .....	99
9.3	Power Supply Module Characteristics .....	99
9.3.1	Power Supply Module to Cage Interconnect .....	99
9.3.2	Output Current Ratings .....	100



- 9.3.3 Air Flow ..... 100
- 9.3.4 Thermal Protection ..... 100
- 9.4 AC-input Power Supply Module ..... 101
  - 9.4.1 AC-Input PSU Mechanical Specification ..... 101
  - 9.4.2 AC-Input PSU Power Input Connector ..... 101
  - 9.4.3 AC-Input PSU LED Indicators ..... 101
- 9.5 DC-input Power Supply Module ..... 102
  - 9.5.1 DC-Input PSU Mechanical Specification ..... 102
  - 9.5.2 DC-Input PSU Power Input Connector ..... 103
  - 9.5.3 DC-Input PSU LED Indicators ..... 103
- 10.0 Regulatory Specifications** ..... 104
  - 10.1 Safety Compliance ..... 104
  - 10.2 Electromagnetic Compatibility ..... 104
  - 10.3 CE Mark ..... 104
- A Glossary** ..... 105

## Figures

- 1 Intel® Carrier Grade Server TIGH2U with Top Cover On ..... 12
- 2 Intel® Carrier Grade Server TIGH2U with Top Cover Removed ..... 13
- 3 Carrier Grade Server TIGH2U Block Diagram ..... 16
- 4 Front View of System (Bezel Installed) ..... 17
- 5 Front View of System (Bezel Removed) ..... 17
- 6 Front Panel Details ..... 18
- 7 Hard Drive and Optical Drive ..... 20
- 8 Hard Drive Tray Assembly ..... 20
- 9 Optical Drive and Engagement Tab ..... 21
- 10 Rear View ..... 22
- 11 Removing and Installing the PCI Riser Assembly ..... 25
- 12 Installing Add-in Cards in PCI Riser Assembly ..... 25
- 13 Cooling Fans ..... 26
- 14 Carrier Grade Server TIGH2U System Interconnect Block Diagram ..... 33
- 15 Flex Circuit Cable ..... 34
- 16 IDE Signal Cable Physical Details ..... 36
- 17 SAS Backplane Power Cable ..... 37
- 18 TAM Board Signal Cable ..... 38
- 19 Telco Alarms Signal Cable ..... 39
- 20 Intel® Z-U130 Value Solid State Drive Signal and Power Cable Physical Details ..... 40
- 21 SAS RAID Battery Power Cable Physical Details ..... 40
- 22 Front-Panel Serial Port Cable Physical Details ..... 41
- 23 Keyboard and Mouse Connectors ..... 42
- 24 Serial Port Connector ..... 43
- 25 Video Connector ..... 44
- 26 External USB Connector ..... 45
- 27 Ethernet Connectors ..... 46
- 28 External SAS 4X Hard Disk Drive Connector ..... 46
- 29 AC Power Input Connector ..... 47
- 30 DC Power Input Connector ..... 47
- 31 Alarms Connector ..... 48
- 32 SAS Front Panel Board Functional Block Diagram ..... 51
- 33 SFP Board Component Locations ..... 52
- 34 SFP Board Front View ..... 52
- 35 SFP Board Power Conversion ..... 53



36	I/O Subsystem Block Diagram .....	56
37	I <sup>2</sup> C Circuit .....	58
38	LSISAS1068 Circuit .....	59
39	SFP Board Clock Generation and Distribution Circuit .....	60
40	Reset Control .....	64
41	SAS Backplane Block Diagram .....	75
42	TAM Board on Mounting Bracket.....	81
43	Intel® Z-U130 Value Solid State Drive Connection to Interposer Board.....	87
44	Intel® Z-U130 Value Solid State Drive Dimensions .....	87
45	Full-Height PCI-X / PCIe Riser Card .....	90
46	Low-Profile PCIe Riser Card .....	90
47	Low-Profile Passive PCIe Riser Card Mechanical Specification .....	92
48	Full-Height PCI-X / PCIe Riser Card Mechanical Specification .....	93
49	Power Supply Cage Mechanical Specification .....	95
50	Power Supply Cage Output Wire Harness Detail.....	96
51	Power Supply Module Output Connector .....	100
52	AC-Input Power Supply Module Mechanical Specification.....	102
53	AC-Input Power Supply Module Input Connector.....	102
54	DC-Input Power Supply Module Mechanical Specification .....	103
55	DC-Input Power Supply Module Input Connector .....	104

**Tables**

1	Carrier Grade Server TIGH2U Feature List .....	14
2	Front Panel Features .....	18
3	Rear Panel Components .....	22
4	Full-Height Riser Card Configurations and Throughput.....	23
5	Low-profile PCI Add-in Card Configurations and Throughput.....	23
6	Fan Speed Settings .....	27
7	Server Management Features .....	29
8	Environmental Specifications Summary .....	30
9	Physical Dimensions .....	31
10	Shipping Weights .....	31
11	Front Panel Flex Connector Pin-Out .....	34
12	IDE Signal Cable Connector J3G1 Pin-out .....	36
13	SAS Backplane Power Cable Connections.....	37
14	TAM Board Signal Cable Connections .....	38
15	Alarms Connection Pinout.....	39
16	Intel® Z-U130 Value Solid State Drive 2 X 3 Connector Pin-Out.....	40
17	Battery Backup Unit Power Cable Connector .....	41
18	Front Panel Serial Cable Connections .....	42
19	Keyboard and Mouse Port Pin-Out .....	42
20	Rear Panel Serial Port (RJ45) Connector Pinout .....	43
21	Front Panel Serial Port (RJ45) Connector Pinout .....	44
22	Video Connector Pin-Out .....	44
23	USB Connector Pin-Out .....	45
24	Ethernet Connector Pin-Out .....	46
25	External SAS 4X Hard Disk Drive Connector Pin-Out .....	46
26	Alarms Connector Pin-Out .....	48
27	Power Good Table .....	63
28	Baseboard Bridge Connector Pinout .....	64
29	Intel® RAID Smart Battery Connector (J8B2) Pinout .....	66
30	DDR2 DIMM Connector (J6D1) Pinout .....	66
31	SAS Flex Connector (J2B1) Pinout .....	68
32	Serial Cable Header (J8B1) Pinout .....	69



33	SAS Backplane Power Connector (J1D2) .....	70
34	PDB Power Connector (J2D2) Pinout.....	70
35	PDB Power Connector (J2D1) Pinout.....	70
36	External USB / Serial Port Connector (J8E1) Pinout .....	71
37	80333 Processor UART Connector (J3B1) Pinout .....	71
38	Upper Fan Connector (J1D1) Pinout .....	71
39	Lower Fan Connector (J1C1) Pinout.....	72
40	CPU1 Fan Connector (J7A1) Pinout.....	72
41	CPU2 Fan Connector (J7A2) Pinout.....	72
42	Intel® Z-U130 Value Solid State Drive Connector Pinout .....	73
43	2 x 40 Flex Cable Connector (J5A1) Pinout.....	76
44	Hard Drive Connectors (J5C2, J5C1, J5B1, J2C2, J2C1, J2B1) Pinout .....	77
45	2 x 22 Slim-Line IDE Optical Drive Connector (J6M1) Pinout.....	77
46	50-pin Connector to Slim-Line Optical Device (J2A1) Pinout.....	78
47	12-pin Power Connector to Front Panel Board (J3L1) Pinout .....	79
48	Front Panel Switches.....	81
49	Front Panel LEDs.....	82
50	System Status LEDs.....	82
51	System Fault LEDs.....	83
52	SFP Interface Connector Pinout .....	83
53	Alarms Connector Pinout .....	84
54	2 x 3 Connector Pinout.....	88
55	Full-Height Riser Card Configurations and Throughput .....	91
56	Low-Profile Riser Card Configurations and Throughput .....	91
57	Power Supply Cage Wiring Harness Cable Lengths .....	96
58	24-pin Server Board Power Connector Pinout .....	97
59	P2 Processor Power Connector Pinout .....	97
60	P3 Power Signal Cable Pinout .....	98
61	P4 SFP Board Power Connector Pinout .....	98
62	P5 SFP Board Power Connector Pinout .....	98
63	+12V Outputs Load Ratings .....	99
64	DC/DC Converters Load Ratings .....	99
65	Power Supply Module Output Connector Pinout .....	100
66	PSU Load Ratings .....	101
67	AC-Input PSU LED Indicators .....	103
68	DC-Input PSU LED Indicators .....	104





## Revision History

---

Date	Revision	Description
April 2008	004	Miscellaneous updates: <ul style="list-style-type: none"><li>- Processor and component name corrections</li><li>- Minor grammar edits</li></ul>
November 2007	003	Updates for gold release: <ul style="list-style-type: none"><li>- Change to add Intel® Z-U130V Value Solid State Drive and remove SysCon board</li><li>- Change to RAID component product names to follow corporate naming guidelines</li></ul>
September 2007	002	Updates include: <ul style="list-style-type: none"><li>- Changes to PCI fan assembly and PCI card retainer</li><li>- Changes to the TAM board graphic</li><li>- Removal of references to "dual core" processors.</li></ul>
July 2007	001	Initial version of document



## 1.0 Introduction

---

This document provides an overview of the Intel® Carrier Grade Server TIGH2U, including information about the chassis hardware, cables, connectors, system boards, power subsystem, and regulatory requirements.

### 1.1 Document Structure and Outline

This document is organized into the following chapters:

- Chapter 1.0, "Introduction" — Provides an overview of this document.
- Chapter 2.0, "System Overview" — Provides an overview of the Intel® Carrier Grade Server TIGH2U chassis hardware.
- Chapter 3.0, "Cables and Connectors" — Describes the cables and connectors used to interconnect the system board set and the server system components. Also describes external, user-accessible connectors.
- Chapter 4.0, "SAS Front Panel (SFP) Board" — Describes the specifications of the front panel I/O board and describes the main functions of the board. Also, describes special features including support for RAID, debug facility, "power good" circuit and reset control and provides pinout information for SFP board connectors.
- Chapter 5.0, "SAS Backplane" — Describes the specifications of the SAS backplane that provides support for the SAS hard disk drives and the optical disk drive.
- Chapter 6.0, "TAM Board" — Describes the Telco Alarm Manager (TAM) board that provides front panel switches and LEDs and system alarm relays that can be used for external alarm indication.
- Chapter 7.0, "Intel® Z-U130 Value Solid State Drive" — Describes the specifications of the Intel® Z-U130 Value Solid State Drive.
- Chapter 8.0, "PCI Riser Cards" — Describes the specifications of the PCI riser cards.
- Chapter 9.0, "Power Subsystem" — Describes the specifications of the power subsystem, including AC-input and DC-input power supply modules.
- Chapter 10.0, "Regulatory Specifications" — Describes system compliance to regulatory specifications.

A glossary of terms and a list of useful references on related subjects is provided at the end of the manual.



## 1.2 Related Information

The following documents are referenced in this document and provide additional information:

- *Intel® Server Board S5000PAL/S5000XAL Technical Product Specification*
- *25-GS0009 Boards and Systems Environmental Governing Specification*
- *Intel® Embedded Server RAID Technology II, Intel® Integrated Server RAID, and Intel® RAID Controllers SRCSAS18E and SRCSAS144E Software User's Guide*
- *Intel® Z-U130 Value Solid State Drive Datasheet*

## 2.0 System Overview

---

This chapter describes the features of the Intel® Carrier Grade Server TIGH2U.

This chapter is organized into the following sections.

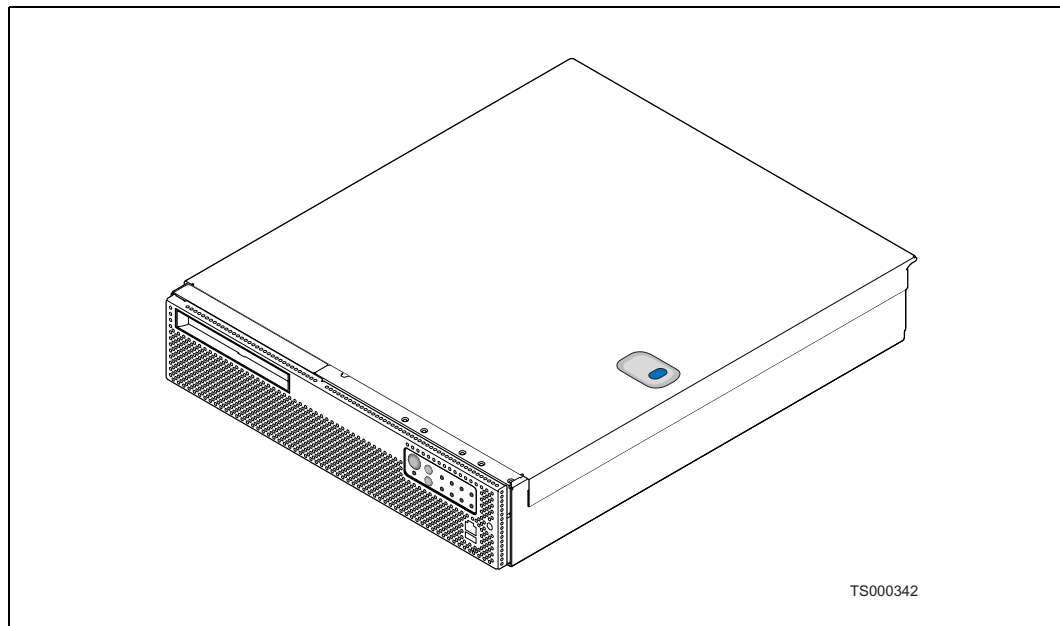
- Product Overview
- External Chassis Features
- Internal Chassis Features
- Server Management
- Specifications

### 2.1 Product Overview

The Intel® Carrier Grade Server TIGH2U is a compact, high-density, rack mount server system with support for selected quad-core processor models from the Intel® Xeon® 5000 sequence, and up to 32 Gbytes of DDR2-667 FBD ECC DIMM memory. The TIGH2U supports high availability features such as hot-swappable SAS disk drives, redundant hot-swappable power supply modules and memory mirroring. The scalable architecture of the TIGH2U supports a variety of operating systems.

Figure 1 shows the Carrier Grade Server TIGH2U assembled and Figure 2 shows the TIGH2U server with the top cover and front bezel removed.

**Figure 1. Intel® Carrier Grade Server TIGH2U with Top Cover On**



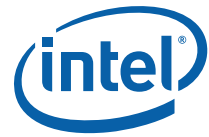
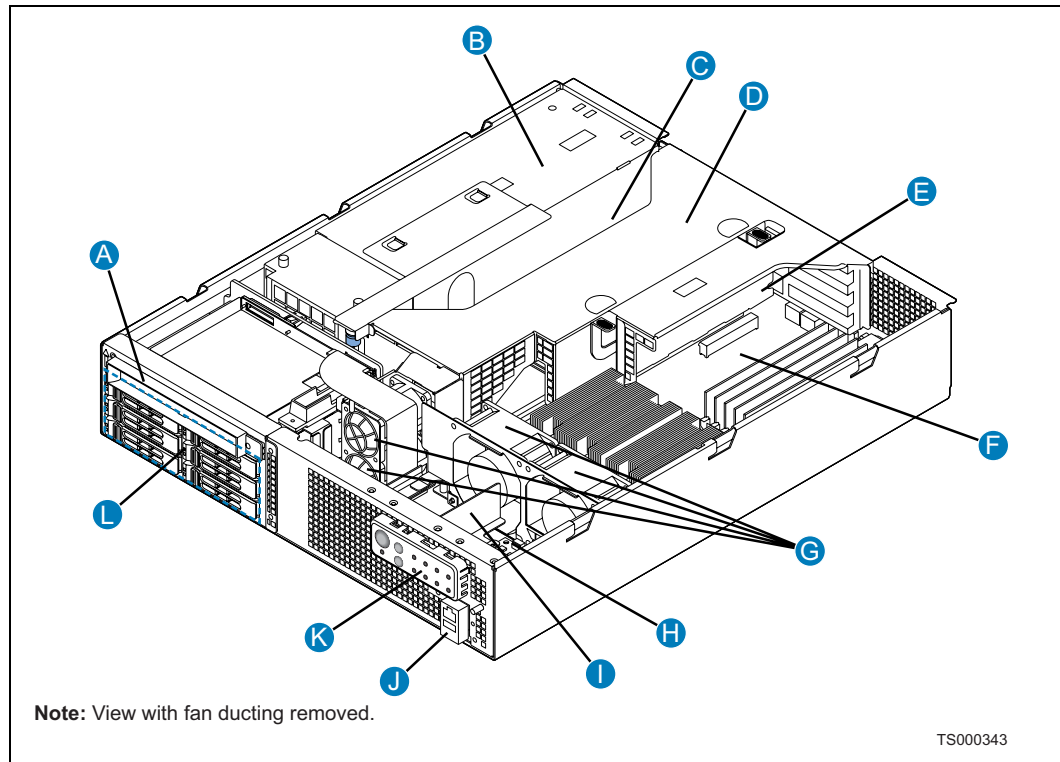


Figure 2. Intel® Carrier Grade Server TIGH2U with Top Cover Removed



Item	Description	Item	Description
A	Optical drive	G	System fans
B	Power supply cage (contains one power supply module with provision for an optional second module)	H	SAS Front Panel (SFP) board
C	Provision for PCI-X* and PCI Express* (PCIe*) full-height and full-length add-in cards	I	TAM board (behind front panel) <b>Note:</b> The bracket on which the TAM board is installed can also include an optional Intel® Z-U130 Value Solid State Drive, which provides local memory storage
D	Riser card assembly (containing riser cards for both full-height and low-profile add-in cards)	J	RJ45 COM2 and USB port 2 connectors
E	Provision for two PCI Express low-profile add-in cards	K	Control panel and status indicators
F	Intel® Server Board T5000PAL	L	Hot-swappable SAS 2.5-inch disk drives (up to six)



### 2.1.1 Features

Table 1 provides a list and brief description of the features of the Carrier Grade Server TIGH2U.

**Table 1. Carrier Grade Server TIGH2U Feature List**

Feature	Description				
Compact, high-density system	Rack mount server with a height of 2U (3.5 inches, 8.9 cm) and a depth of 20.0 inches (50.8 cm)				
Configuration flexibility	One- or two-way capability in low-profile and cost / value-effective packaging Stand-alone system Selected quad-core processor models from the Intel® Xeon® 5000 sequence (one or two) †				
Serviceability	Rear access to hot-swappable power supplies Front access to hot-swappable SAS disk drives Front access to optical drive Ability to swap the entire drive bay as a unit				
Availability	Two hot-swappable 600 W power supplies in a redundant (1+1) configuration Disk subsystem configurable as hardware or software RAID Memory sparing and memory mirroring configurations supported				
Manageability	Remote management Emergency management port (serial and LAN) IPMI 2.0 compliant Remote diagnostics support Optional Intel® Z-U130 Value Solid State Drive Optional Intel® Remote Management Module 2 (Intel® RMM2) providing GCM support				
Upgradeability and investment protection	Supports selected quad-core processor models from the Intel® Xeon® processor 5000 sequence Multi-generational chassis Intel® 64 architecture support (formerly known as Intel® Extended Memory 64 Technology or Intel® EM64T)				
System-level scalability	Supports up to 32 Gbytes FB-DIMM memory in non-mirrored mode Supports up to 16 Gbytes FB-DIMM memory in mirrored mode Supports selected quad-core processor models from the Intel® Xeon® processor 5000 sequence (one or two) † Two full-height / full-length x4 PCI Express slots One full-height / full-length 64-bit x 133 MHz PCI-X slot Two low-profile / half-length x4 PCI Express slots Six internal hot-swappable 2.5-inch SAS disk drives One optical drive (optional)				
Front panel	<table border="0"> <tr> <td>Switches:</td> <td>LEDs / Relays:</td> </tr> <tr> <td> <ul style="list-style-type: none"> <li>• Power switch</li> <li>• Reset switch</li> <li>• NMI switch</li> <li>• ID switch</li> </ul> </td> <td> <ul style="list-style-type: none"> <li>• Telco critical alarm fault LED / Relay</li> <li>• Telco major alarm fault LED / Relay</li> <li>• Telco minor alarm fault LED / Relay</li> <li>• Telco power alarm fault LED / Relay</li> <li>• ID LED</li> <li>• NIC activity LED</li> <li>• Main power LED</li> <li>• HDD activity LED</li> </ul> </td> </tr> </table>	Switches:	LEDs / Relays:	<ul style="list-style-type: none"> <li>• Power switch</li> <li>• Reset switch</li> <li>• NMI switch</li> <li>• ID switch</li> </ul>	<ul style="list-style-type: none"> <li>• Telco critical alarm fault LED / Relay</li> <li>• Telco major alarm fault LED / Relay</li> <li>• Telco minor alarm fault LED / Relay</li> <li>• Telco power alarm fault LED / Relay</li> <li>• ID LED</li> <li>• NIC activity LED</li> <li>• Main power LED</li> <li>• HDD activity LED</li> </ul>
Switches:	LEDs / Relays:				
<ul style="list-style-type: none"> <li>• Power switch</li> <li>• Reset switch</li> <li>• NMI switch</li> <li>• ID switch</li> </ul>	<ul style="list-style-type: none"> <li>• Telco critical alarm fault LED / Relay</li> <li>• Telco major alarm fault LED / Relay</li> <li>• Telco minor alarm fault LED / Relay</li> <li>• Telco power alarm fault LED / Relay</li> <li>• ID LED</li> <li>• NIC activity LED</li> <li>• Main power LED</li> <li>• HDD activity LED</li> </ul>				
† To get a list of compatible processors for the TIGH2U, see <a href="http://support.intel.com/support/telecom/computeboards/tigh2u/">http://support.intel.com/support/telecom/computeboards/tigh2u/</a> .					

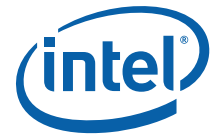


Table 1. Carrier Grade Server TIGH2U Feature List (Continued)

Feature	Description
I/O	<div style="display: flex; justify-content: space-between;"> <div style="width: 45%;"> <p>Front panel:</p> <ul style="list-style-type: none"> <li>Serial B port (RJ45)</li> <li>USB 2.0 port</li> </ul> </div> <div style="width: 45%;"> <p>Rear panel:</p> <ul style="list-style-type: none"> <li>Dual PS/2 ports for keyboard and mouse</li> <li>Serial B port (RJ45)</li> <li>Two USB 2.0 ports</li> <li>Intel® RMM2 NIC 100 Mbps management port</li> <li>Two RJ45 NIC connectors for 10 / 100 / 1000 Mbps connections</li> <li>Video connector</li> <li>Alarms connector</li> </ul> </div> </div>
Internal connection options	<p>Internal connectors/headers:</p> <ul style="list-style-type: none"> <li>One 44-pin ATA/100 connector (power and I/O) for optical drive</li> <li>One Intel® Remote Management Module 2 (Intel® RMM2) connector</li> <li>One Intel® I/O Expansion Module (optional) supporting either: <ul style="list-style-type: none"> <li>a dual GbE NIC Intel® connection</li> <li>an external x4 SAS drive</li> </ul> </li> </ul>
Add-in card support	<p>One full-height riser slot supporting 2U PCI-X and PCI Express (PCIe) add-in cards</p> <p>One low-profile riser slot supporting PCIe add-in cards</p>
<p>† To get a list of compatible processors for the TIGH2U, see <a href="http://support.intel.com/support/telecom/computeboards/tigh2u/">http://support.intel.com/support/telecom/computeboards/tigh2u/</a>.</p>	

The Intel® Server Board T5000PAL is mounted horizontally toward the rear of the chassis, behind the system fan array.

Up to six 2.5-inch, hot-swappable, SAS-technology hard drives can be mounted in the drive bays, which are located in the left, front area of the chassis behind the front bezel. Figure 2 shows the location of the SAS drive trays.

*Note:* It is possible to swap the entire drive bay as a unit if the unit needs to be moved to another system.

The SAS Front Panel (SFP) board is located in front of the CPU fan array and provides the user interface on the system front panel for system management.

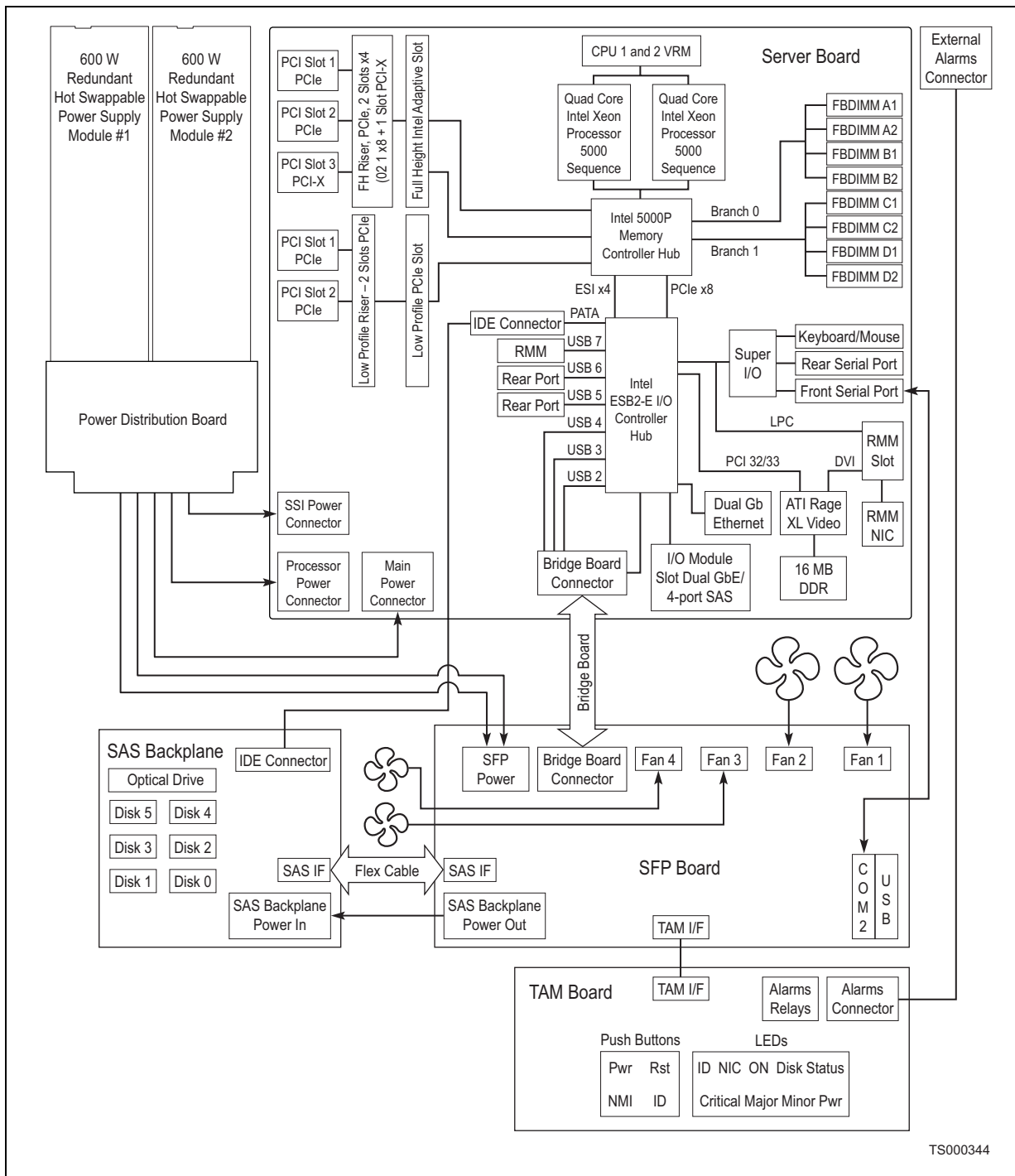
The power supply modules are installed at the left-rear of the chassis. Two hot-swappable 600 W power supply modules can be installed for a 1 + 1 redundant configuration. A filler module for the empty power supply location is supplied for systems without redundancy.

The system contains a fan array consisting of two 80 × 38 mm fans (CPU fans) and two 56 × 40 mm fans (PCI fans) to cool the server board, PCI riser assembly and other components. The two 80 × 38 mm fans are installed directly behind the SFP board in front of the server board. The two 56 × 40 mm fans are located to the left of the SFP board. A fan failure is indicated by a fault LED on the SFP board.

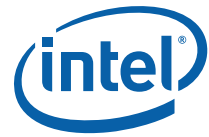
The front bezel can be customized to meet OEM industrial design requirements. The bezel design allows adequate airflow to cool the system components. The front bezel is removed to access the drive trays.

Figure 3 shows a block diagram of the Carrier Grade Server TIGH2U, depicting major system components and the interconnections between them.

Figure 3. Carrier Grade Server TIGH2U Block Diagram





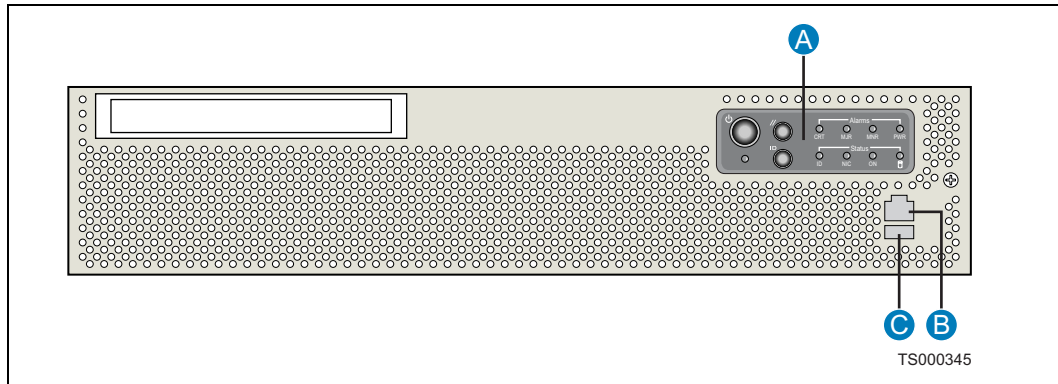


## 2.2 External Chassis Features

### 2.2.1 TIGH2U System Front Views

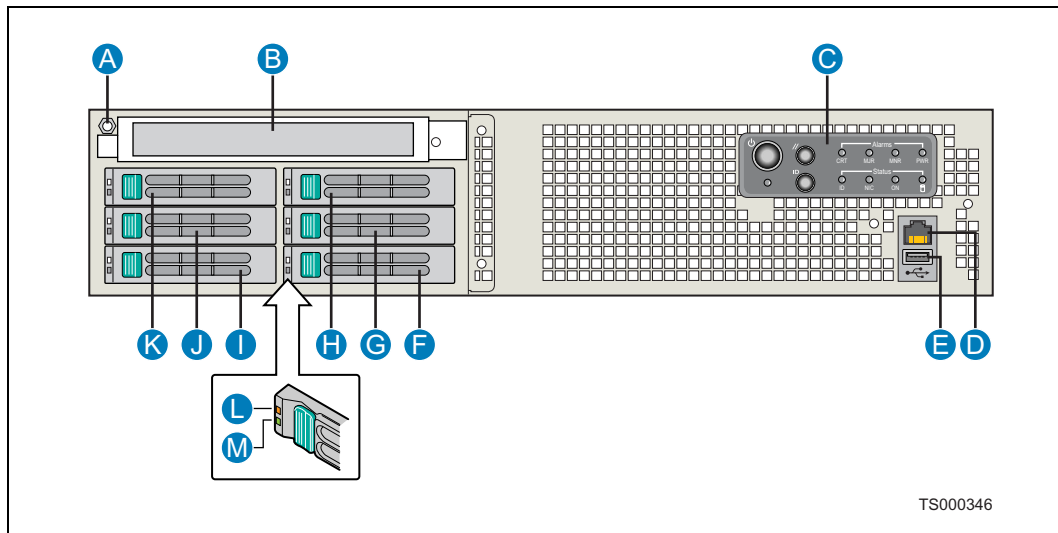
Figure 4 shows the front of the Carrier Grade Server TIGH2U system with the bezel installed. Figure 5 shows the front of the system with the bezel removed. Removing the bezel provides access to the hot-swappable SAS disk drives and the optical drive.

Figure 4. Front View of the TIGH2U System (Bezel Installed)



Item	Description	Item	Description
A	Front panel control switches and status LEDs (see Figure 6 for details)	C	USB Port
B	COM Port		

Figure 5. Front View of TIGH2U System (Bezel Removed)



Item	Description	Item	Description
A	Anti-static connection point	H	Hard drive bay 4
B	Optical drive (optional) or filler panel	I	Hard drive bay 1
C	Front panel control switches and status LEDs (see Figure 6 for details)	J	Hard drive bay 3
D	Front-panel serial port connector (RJ45)	K	Hard drive bay 5
E	USB port 2 connector	L	Drive fault indicator (one per hard drive)
F	Hard drive bay 0	M	Drive activity indicator (one per hard drive)
G	Hard drive bay 2		

### 2.2.2 Front Panel Features

The front panel features of the Carrier Grade Server TIGH2U are shown in Figure 6 and described in Table 2. All front panel control switches and status LEDs are located on the Telco Alarm Management (TAM) board. See Chapter 6.0, "TAM Board" for more information.

Figure 6. Carrier Grade Server TIGH2U Front Panel Details

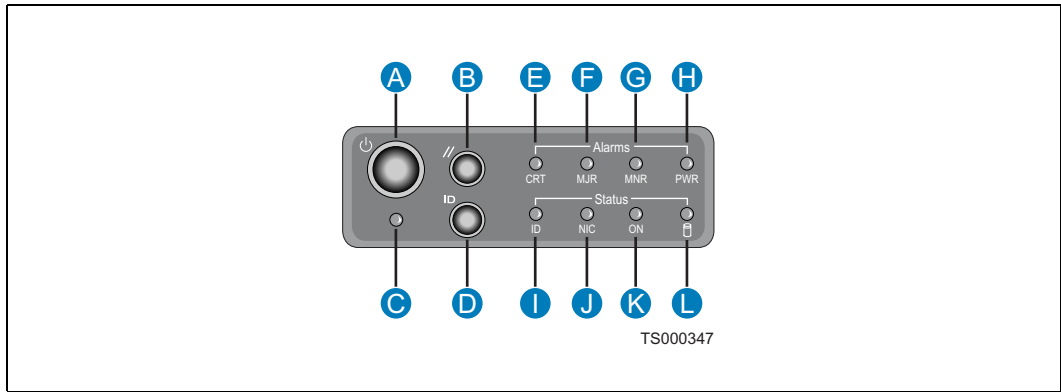


Table 2. Carrier Grade Server TIGH2U Front Panel Features

Item	Feature	Description
<b>Front Panel Switches</b>		
A	Power switch	Toggles the system power
B	Reset switch	Resets the system
C	NMI switch (pin hole)	Asserts NMI to the server board
D	ID switch	Toggles system ID LED on / off
<b>Front Panel Alarm LEDs and Relays</b>		
E	Critical (Default color is amber)	The Critical alarm LED can be either amber (default) or red (when set with an RFUSDR update). When continuously lit, indicates the presence of a Critical System Fault. A critical system fault is an error or event that is detected by the system with a fatal impact to the system. In this case, the system cannot continue to operate. An example is the loss of a large section of memory, or other corruption, that renders the system not operational. The front panel critical alarm relay is engaged.

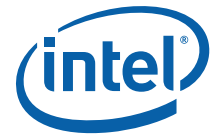


Table 2. Carrier Grade Server T1GH2U Front Panel Features (Continued)

Item	Feature	Description
F	Major (Default color is amber)	The Major alarm LED can be either amber (default) or red (when set with an RFUSDR update). When continuously lit, indicates the presence of a Major System Fault. A major system fault is an error or event that is detected by the system that has discernable impact to system operation. In this case, the system can continue to operate but in a “degraded” fashion (reduced performance or loss of non-fatal feature reduction). An example is the loss of one of two mirrored disks. The front panel major alarm relay is engaged.
G	Minor (amber)	When continuously lit, indicates the presence of a Minor System Fault. A minor system fault is an error or event that is detected by the system but typically has little impact to actual system operation. An example is a correctable ECC error. The front panel minor alarm relay is engaged.
H	Power (amber)	When continuously lit, indicates the presence of a Power System Fault. The front panel power alarm relay is engaged.
Front Panel Status LEDs		
I	System ID LED (white)	Indicates system identity LED can be toggled remotely or by front-panel ID switch for identification purposes
J	NIC activity LED (green)	Indicates NIC activity when lit
K	Main power LED (green)	When continuously lit, indicates the presence of power supply DC output power in the server. The LED turns off when the main output power from the power supply is turned off or the power source is disrupted.
L	HDD Activity / Fault LED (green / amber)	Indicates HDD activity when green, or an HDD fault when amber. This is an aggregated indication for all hard disk drives (up to six) in the system. Each hard disk contains its own activity and fault indicators.

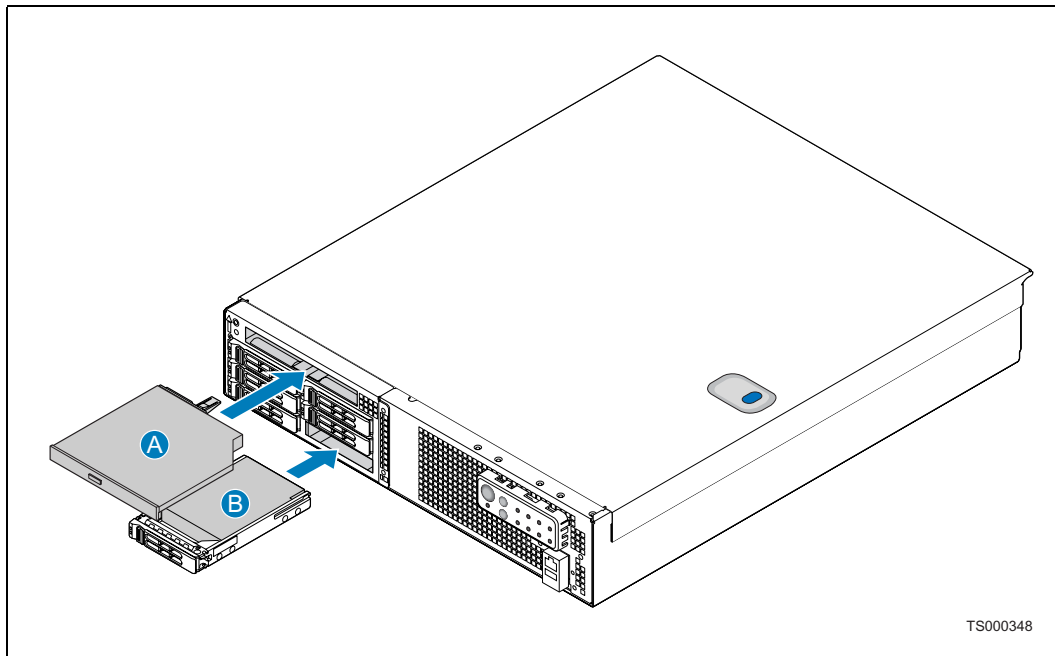
### 2.2.3 Hard Drives and Optical Drive

The Carrier Grade Server T1GH2U chassis can include up to six hot-swappable 2.5-inch hard drives (item B in Figure 7) that are accessible from the front of the chassis and provision for an optional front-accessible optical drive (item A in Figure 7).

SAS 2.5-inch hard disk drives are mounted in removable drive trays that latch into the drive bay subassembly. The SAS drives are hot-swappable. The optical drive, which is **not** hot-swappable, is mounted in a slot above the hard drives.

The front bezel must be removed to access the SAS drives. To remove the optical drive, both the top cover and the front bezel must be removed.

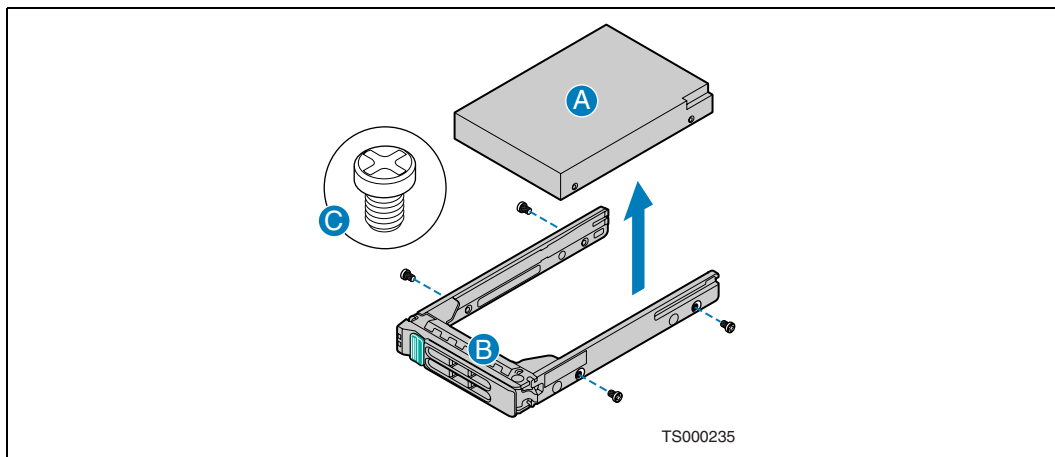
Figure 7. Hard Drive and Optical Drive



### 2.2.3.1 Hard Drive Tray Assembly

Each hard drive used is a hot-swappable. A hard drive is removed by pressing the green button on the front of the hard drive tray and pulling the hard drive tray from the system. As indicated in Figure 8, the hard drive (A) can be separated from the hard drive tray (B) by removing the four screws (C).

Figure 8. Hard Drive Tray Assembly





### 2.2.3.2 Optical Drive

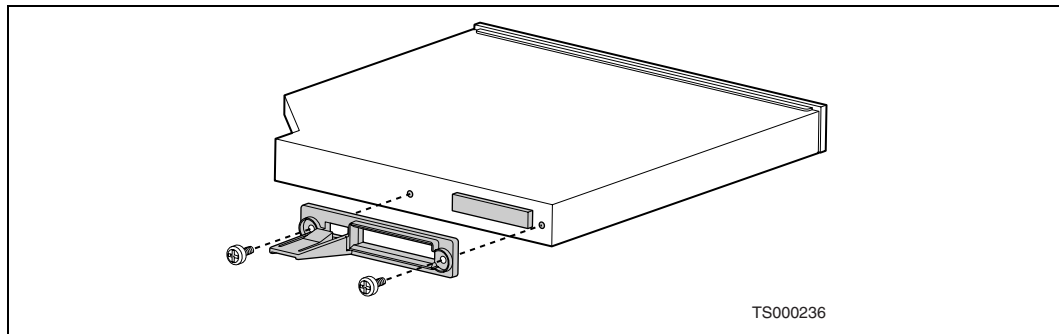
The Carrier Grade Server T1GH2U supports an optional 0.5 inch (12.7 mm) slim-line optical drive.

To install an optical drive, the chassis top cover and the front bezel must be removed. A blank filler unit is then removed by releasing the engagement tab from the SAS backplane and sliding the filler unit out through the front of the chassis. See Figure 7.

The engagement tab must be removed from the blank filler panel and attached to the optical drive using the two mounting screws shown in Figure 9. The optical drive is then installed through the front of the chassis. The engagement tab holds the optical drive firmly in position.

*Note:* The optical drive should be inserted or removed only when the system is powered off.

**Figure 9. Optical Drive and Engagement Tab**



### 2.2.4 TIGH2U System Chassis Rear Panel

Figure 10 shows the rear of the Carrier Grade Server TIGH2U system and Table 3 describes the main components.

Figure 10. TIGH2U Rear View

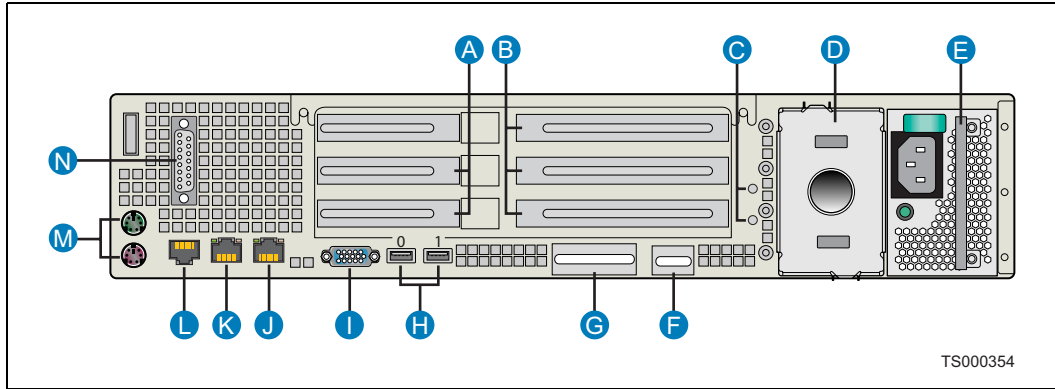


Table 3. Rear Panel Components

Item	Description	Item	Description
A	Low-profile PCI Express add-in cards (or filler panels)	H	USB 0 and USB 1 port connectors
B	Full-height PCI-X/PCI Express add-in cards (or filler panels)	I	Video connector
C	Ground studs (used for DC-input system)	J	GbE NIC #2 connector
D	Power supply 2 slot; filler panel shown	K	GbE NIC #1 connector
E	Power supply 1 †	L	RJ45 serial port connector
F	RMM2 NIC connector (optional) ††	M	PS/2 keyboard and mouse connectors
G	I/O expansion module connector (optional) †††	N	Alarms connector
†	In Figure 10, the power supply shown is an AC-input module. DC-input modules are also available.		
††	If an RMM2 NIC is not present, a filler panel occupies this space.		
†††	May be either an external SAS port connector or Gigabit Etherport port connector. If neither of the optional modules is installed, a filler panel occupies this space.		

### 2.2.5 Rear Panel Ethernet Ports

The TIGH2U has two GbE NIC ports that are mounted on the server board and accessible from the rear of the chassis.

Additional rear-accessible GbE NIC ports can be added by using full-height PCI-X/PCIe add-in cards or low-profile PCIe add-in cards. The possible configurations of full-height PCI-X/PCIe add-in cards are given in Table 4 and the possible configurations of low-profile PCIe add-in cards are given in Table 5.

A dual GbE I/O option module is also available. This module adds two RJ45, 1 Gigabit Ethernet ports accessible on the rear panel.

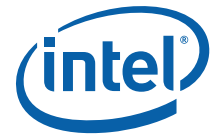


Table 4. Full-Height Riser Card Configurations and Throughput

Configuration	Bottom Slot	Middle Slot	Top Slot
1 add-in card	PCI-X †	–	–
	–	x8 or x4 PCIe	–
	–	–	x4 PCIe
2 add-in cards	PCI-X †	x8 or x4 PCIe	–
	PCI-X †	–	x4 PCIe
	–	x4 PCIe	x4 PCIe
3 add-in cards	PCI-X †	x4 PCIe	x4 PCIe
<b>Note:</b> † Up to 133 MHz bus speed			

Table 5. Low-profile PCI Add-in Card Configurations and Throughput

Configuration	Lower Slot	Upper Slot
1 add-in card	x4 PCIe	
		x4 PCIe
2 add-in cards	x4 PCIe	x4 PCIe

The GbE NIC ports are intended to be installed with shielded cabling that is grounded at both ends of the cable.

**Warning:** The intra-building port(s) of the equipment or subassembly is suitable for connection to intra-building or unexposed wiring or cabling only. The intra-building port(s) of the equipment or subassembly **MUST NOT** be metalically connected to interfaces that connect to the OSP or its wiring. These interfaces are designed for use as intra-building interfaces only (Type 2 or Type 4 ports as described in GR-1089-CORE, Issue 4) and require isolation from the exposed OSP cabling. The addition of Primary Protectors is not sufficient protection to connect these interfaces metalically to OSP wiring.

## 2.3 Internal Chassis Features

### 2.3.1 Intel® Server Board T5000PAL

The T1GH2U uses the Intel® Server Board T5000PAL. The T5000PAL server board is very similar to the S5000PAL server board as documented in the *Intel® Server Board S5000PAL/S5000XAL Technical Product Specification* with modifications to optimize its use in telecommunications servers.

Most modifications do not change the functional characteristics of the board, with the exception of serial header J1H2, which has been added to accommodate the connection of the front panel serial port cable (see Figure 14, “Carrier Grade Server T1GH2U System Interconnect Block Diagram” on page 34).



### 2.3.2 PCI/PCI Express Subsystem

The Carrier Grade Server TIGH2U incorporates a PCI riser assembly that supports installing PCI-X and PCI Express add-in boards. The assembly includes two riser cards that provide a total of five standard interface slots for add-in boards by connecting to two special slots on the Intel® Server Board T5000PAL.

One of the riser card slots is a PCI super slot that contains the signals necessary to support both PCI-X and PCI Express (PCIe) expansion slots. The riser card that connects to the super slot supports the connection of full-height PCI-X or PCIe add-in cards. For PCI-X add-in cards, the super slot riser card implements a 64-bit PCI-X slot with bus speeds of 66 MHz, 100 MHz, or 133 MHz. For PCIe cards, the super slot riser card implements a ×8 link interface that can be used with one or two add-in cards that implement x1 or x4 interfaces or a single x8 card. See Table 55, “Full-Height Riser Card Configurations and Throughput” on page 94 for the supported configurations.

The second riser card slot supports PCIe only. The low-profile riser card that plugs into this slot supports the connection of low-profile PCIe add-in cards only and implements two ×4 link interfaces. Up to two low-profile PCIe add-in cards can be installed. See Table 56, “Low-Profile Riser Card Configurations and Throughput” on page 94 for the supported configurations.

Add-in cards are inserted into the riser assembly when the assembly is removed from the chassis. Figure 11 shows the removal of the riser assembly. The PCI retention plate (A) must be removed first by sliding the plate back until the two tabs disengage from the slots in the power supply; then the PCI retention plate can be lifted from the chassis.

The locking pin (B) that secures the PCI fan assembly (C) to the riser assembly (D) must also be removed by lifting upward using a finger and removing from the chassis. This allows the the PCI fan assembly (C) to be moved slightly to the left and forward so that it is clear of the riser assembly.

**Caution:** When moving the PCI fan assembly clear of the riser assembly, take care not to damage the flex cable that is routed over the PCI fan assembly.

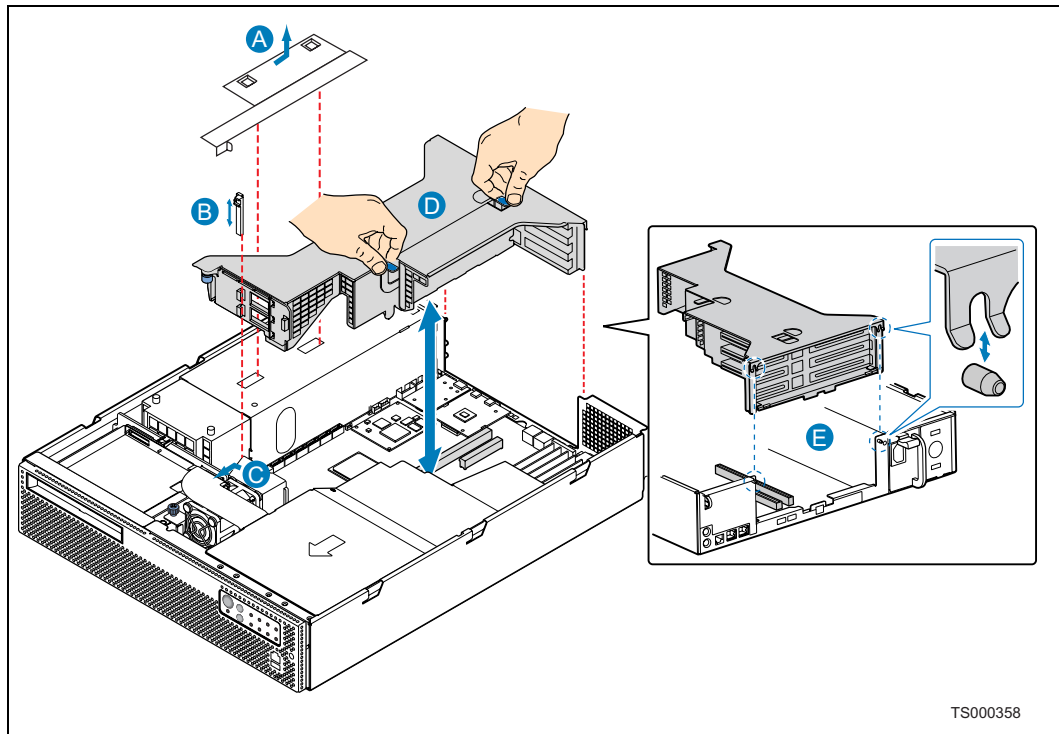
The PCI riser assembly can then be removed by pulling the tabs and lifting it from the chassis. When reinstalling the PCI riser assembly, guide forks (E) help align the PCI riser assembly with alignment pins on the server chassis.

Figure 12 shows the installation of a full-height PCI-X or PCIe add-in card (A) into the full-height riser card (B) and the installation of a low-profile PCIe add-in card (E) into the low-profile riser card (F). The full-height PCI-X or PCIe add-in cards are supported by a retainer clip (C) which is held in the locked position by a captive screw (D).

After the add-in cards are installed, the riser assembly is plugged back into the system and the I/O brackets of all the add-in cards are accessible through the rear panel of the server chassis.

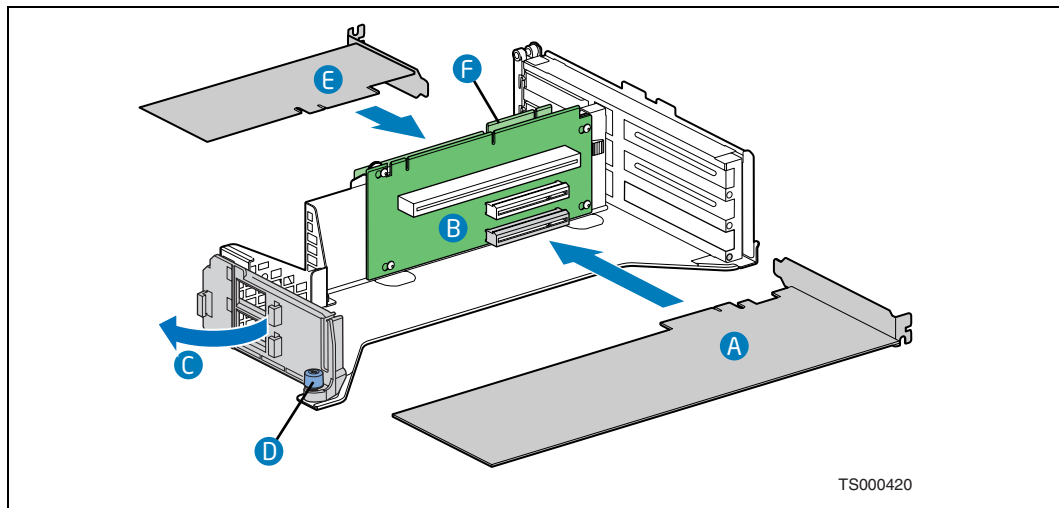


Figure 11. Removing and Installing the PCI Riser Assembly



TS000358

Figure 12. Installing Add-in Cards in PCI Riser Assembly



TS000420

### 2.3.3 Power Subsystem

The power subsystem consists of up to two hot-swappable power supply units (PSUs) and a power distribution board (PDB). The system can be configured and operated with either AC-input or DC-input PSUs located at the left, rear of the chassis. The power supply modules dock into a common PDB.

The system can contain up to two PSUs and can be configured as follows:

- two PSUs installed, (1+1) power redundancy for maximally loaded system
- one PSU installed, non-redundant for maximally loaded system

When the system is configured with two power supply modules, the hot-swap feature allows the user to replace a failed PSU without interrupting system operation. To ensure that all components remain within specification under all system environmental conditions, two minutes is the recommended maximum duration for PSU hot-swap operations.

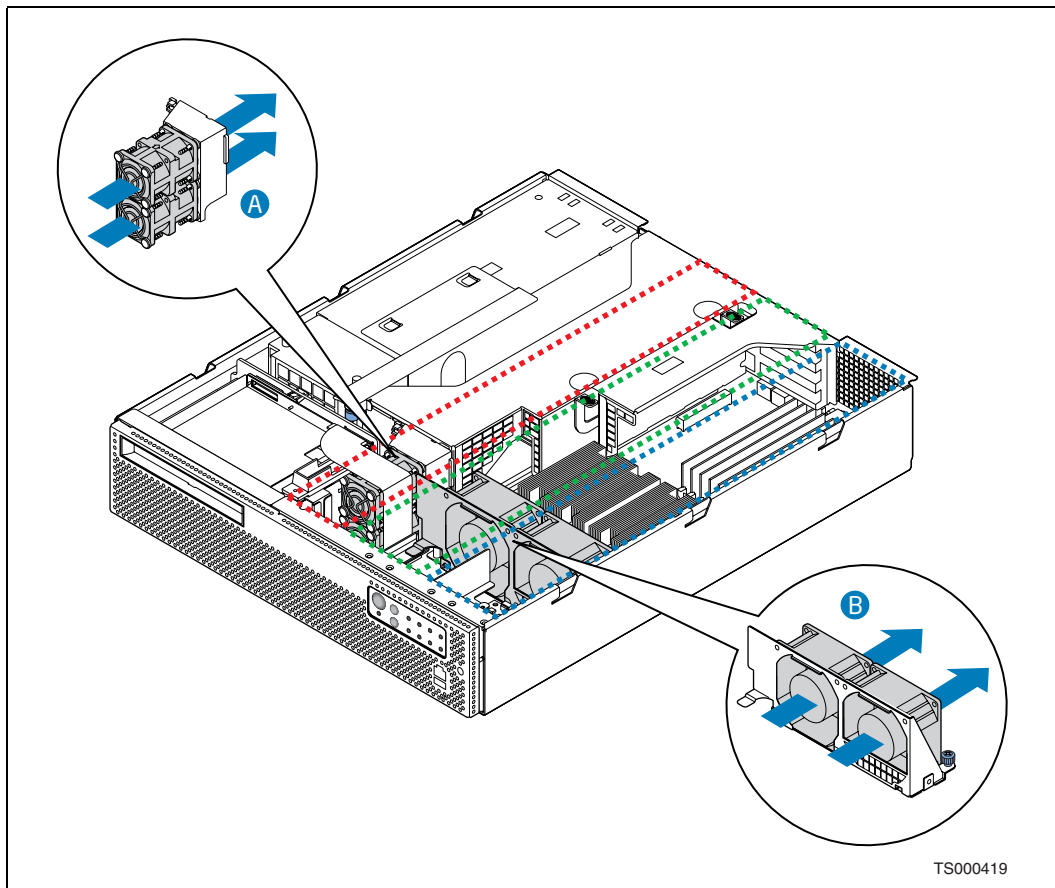
See Chapter 9.0, “Power Subsystem” for more detailed information on the power subsystem.

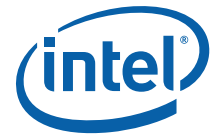
*Note:* When the system is configured with one power supply module, this module must be installed in slot 1, the right slot when facing the rear of chassis.

### 2.3.4 Cooling Subsystem

All system components except the power supply cage, which is cooled by fans integrated into the PSUs, are cooled by two sets of fans mounted near the middle of the chassis, as shown in Figure 13.

Figure 13. Cooling Fans





The Carrier Grade Server TIGH2U system comes in a non-redundant, four-fan configuration that consists of two 56 × 40 mm dual, counter-rotating fan assemblies (A in Figure 13) and two 80 × 38 mm fans (B in Figure 13). Each fan provides a tachometer signal output to allow the server board to monitor the fan speeds. Each fan has an associated fan-failure LED on the SFP board to help isolate a fan failure.

There are three cooling areas (domains) in the TIGH2U system:

- domain 1 - CPU 1 and memory; see area outlined in blue in Figure 13
- domain 2 - CPU 2, chipset, and any low-profile PCIe add-in cards; see area outlined in green in Figure 13
- domain 3 - any full length PCI-X or PCIe add-in cards; see area outlined in red in Figure 13

#### 2.3.4.1 CPU 1 and Memory Cooling Area

One of the system's 80×38 mm fans provides cooling for domain 1 as outlined in blue in Figure 13. This fan facilitates the flow of air through the front bezel over the SFP, through the fan, and over the server board, CPU 1, memory, and ultimately out through the rear of the chassis.

#### 2.3.4.2 CPU 2 and Chipset Cooling Area

One of the system's 80×38 mm fans provides cooling for domain 2 as outlined in green in Figure 13. This fan facilitates the flow of air through the front bezel over the SFP, through the fan, and over the server board, CPU 2, chipset and any low-profile PCIe add-in cards, and ultimately out through the rear of the chassis.

#### 2.3.4.3 PCI Cooling Area

The two 56 × 40 mm dual-rotor fans (A in Figure 13) facilitate the flow of air through the front bezel, through the fans, over the server board and any full-length PCI-X or PCIe add-in cards, and ultimately out through the rear of the chassis.

#### 2.3.4.4 Hard Disk Drive and Power Supply Cooling

Airflow to cool the hard disk drives is provided by fans that are integrated into the PSUs. The airflow is adequate even with a single PSU installed as long as a filler panel is installed in the other PSU slot.

#### 2.3.4.5 Fan Speed Control

The server board contains pulse width modulation (PWM) circuits that control the 12 VDC fan voltage to provide quiet operation when system ambient temperature is low and there are no fan failures. One PWM circuit is available for each cooling domain, resulting in one PWM being connected to each of the two 80 × 38 mm fans and the other PWM connected to the two dual-rotor 56 × 40 mm fans. Based on the ambient temperature, monitored by the front panel sensor, the fan speeds (PWM duty cycle) are set per Table 6.

**Table 6. Fan Speed Settings**

Temperature (°C)	CPU1 Fan PWM DC (%)	CPU2 Fan PWM DC (%)	PCI Fans PWM DC (%)
0 - 28	46	46	46
29	47	47	47
30	48	48	48



Table 6. Fan Speed Settings (Continued)

Temperature (°C)	CPU1 Fan PWM DC (%)	CPU2 Fan PWM DC (%)	PCI Fans PWM DC (%)
31	53	53	53
32	58	58	58
33	63	63	63
34	68	68	68
35	73	73	73
36	78	78	78
37	84	84	84
38	89	89	89
39	95	95	95
40	100	100	100

### 2.3.4.6 Cooling Summary

The four-fan cooling subsystem of the TIGH2U is sized to provide cooling for:

- up to two server board processors
- up to 32 Gbytes of FB-DIMM memory
- up to six SAS hard drives
- up to five PCI add-in cards consuming a maximum of 25 W for each full-height PCI-X / PCIe add-in cards and 10 W for each low-profile PCIe add-in card

The cooling subsystem meets acoustic and thermal requirements at the lower fan speed settings. At the higher fan speed settings, thermal requirements are met for the maximum ambient temperatures, but acoustic requirements are not met. The environmental specifications are summarized in Section 2.5.1, “Environmental Specifications” on page 30.

## 2.4 Server Management

See the *Intel® Server Board S5000PAL Technical Product Specification* for a detailed description of the Server Management design and its features.

The Server Management sub-system provided by the Carrier Grade Server TIGH2U consists of:

- a micro-controller
- communication buses
- sensors
- system BIOS
- server management firmware

Standard on-board platform instrumentation is provided by the Baseboard Management Controller (BMC) component of the ESB2-E.

Table 7 summarizes the supported features.

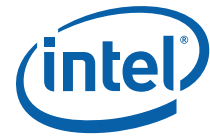


Table 7. Server Management Features

Element	Supported (Yes / No)
IPMI Messaging, Commands, and Abstractions	Yes
Baseboard Management Controller (BMC)	Yes
Sensors	Yes
Sensor Data Records (SDRs) and SDR Repository	Yes
FRU Information	Yes
Autonomous Event Logging	Yes
System Event Log (SEL)	Yes 3,276 entries
BMC Watchdog Timer, covering BIOS and run-time software	Yes
IPMI Channels, and Sessions	Yes
Emergency Management Port (EMP) - IPMI Messaging over Serial / Modem. This feature is also referred to as Direct Platform Control (DPC) over serial / modem.	Yes
Serial / Modem Paging	Yes
Serial / Modem Alerting over PPP using the Platform Event Trap (PET) format	Yes
DPC (Direct Platform Control) - IPMI Messaging over LAN (available via both on-board network controllers) Available over dedicated management port (ESB2 NIC 1)	Yes
LAN Alerting using PET	Yes
Platform Event Filtering (PEF)	Yes
Intelligent Chassis Management Bus (ICMB) - IPMI messaging between chassis	Yes
PCI SMBus support	Yes
Fault Resilient Booting	Yes
BIOS logging of POST progress and POST errors	Yes
Integration with BIOS console redirection via IPMI v2.0 Serial Port Sharing	Yes
Access via web browser	No Requires Intel® Remote Management Module 2 (Intel® RMM2)
SNMP access	Yes
Telnet access	No
DNS support	Yes
DHCP support (dedicated NIC only)	Yes
Memory Sparing / Mirroring sensor support	Yes But does not support mirroring
Alerting via Email	Yes
Keyboard, Video, Mouse (KVM) redirection via LAN	No Requires Intel® Remote Management Module 2 (Intel® RMM)
High speed access to dedicated NIC	Yes



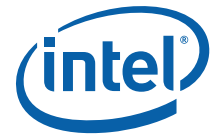
## 2.5 Specifications

### 2.5.1 Environmental Specifications

The Carrier Grade Server TIGH2U system is tested to the environmental specifications indicated in Table 8.

**Table 8. Environmental Specifications Summary**

Environment	Specification
Temperature, operating	5° C to 40° C (41° F to 104° F)
Temperature, non-operating	-40° C to 70° C (-40° F to 158° F)
Altitude	0 to 1,800 m (0 to 5,905 ft) @ 40° C 0 to 4,000 m (0 to 13,123 ft) @ 30° C
Humidity, operating	5% to 85%
Humidity, non-operating	93%, non-condensing at temperatures of 23° C (73° F) to 40° C (104° F)
Vibration, operating	Swept sine survey at an acceleration amplitude of 0.1 g from 5 to 100 Hz and back to 5 Hz at a rate of 0.1 octave/minute, 90 minutes per axis on all three axes as per Bellcore GR-63-CORE standards
Vibration, non-operating	Swept sine survey at an acceleration amplitude of 0.5 g from 5 to 50 Hz at a rate of 0.1 octaves/minute, and an acceleration amplitude of 3.0 g from 50 to 500 Hz at a rate of 0.25 octaves/minute, on all three axes as per Bellcore GR-63-CORE standard 2.2 Grms, 10 minutes per axis on all three axes as per <i>25-GS0009 Boards and Systems Environmental Governing Specification</i>
Shock, operating	Half-sine 2 g, 11 ms pulse, 100 pulses in each direction, on each of the three axes as per <i>25-GS0009 Boards and Systems Environmental Governing Specification</i>
Shock, non-operating	Trapezoidal, 25 g, 170 inches/second delta V, three drops in each direction, on each of the three axes as per <i>25-GS0009 Boards and Systems Environmental Governing Specification</i>
RoHS	Complies with RoHS Directive 2002/95/EC
Safety	UL 60950-1, 1st Edition/CSA 22.2 60950-1, Low Voltage Directive 2006/95/EC, GS to EN60950-1, 1st Edition CB Certificate and Report to IEC60950-1, 1st Edition and all international deviations
Emissions	Certified to FCC Class A; tested to CISPR 22 Class A; EN 55022 Class A, VCCI Class A ITE, AS/NZS 3548 Class A
Immunity	Verified to comply with EN 50082-1
Electrostatic discharge (ESD)	Tested to ESD levels up to 15 kilovolts (kV) air discharge and up to 8 kV contact discharge without physical damage as per <i>25-GS0009 Boards and Systems Environmental Governing Specification</i>
Acoustic	Sound pressure: < 55 dBA at ambient temperatures < 24° C measured at bystander positions in operating mode



## 2.5.2 Physical Specifications

Table 9 provides the physical dimensions of the Carrier Grade Server TIGH2U.

**Table 9. Physical Dimensions**

Dimension	Value
Height	3.45 inches (87.6 mm)
Width	17.14 inches (435.3 mm)
Depth	20.0 inches (508 mm)
Front clearance	2.0 inches (76 mm)
Side clearance	1.0 inches (25 mm)
Rear clearance	3.6 inches (92 mm)

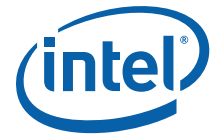
Table 10 provides the shipping weights of the Carrier Grade Server TIGH2U server and associated major components.

**Table 10. Shipping Weights**

Description	Weight (kg)	Weight (lbs)
Intel® Carrier Grade Server TIGH2U, Base Model 0 Includes 600 W <b>AC Power Supply</b> (does not include processor, memory, HDD)	15.8	35.0
Intel® Carrier Grade Server TIGH2U, Base Model 0 Includes 600 W <b>DC Power Supply</b> (does not include processor, memory, HDD)	15.8	35.0
Intel® Carrier Grade Server TIGH2U, standard packaging	3.6	8.0
TIGH2U AC power supply module	1.6	3.5
TIGH2U DC power supply module	1.6	3.5
TIGH2U CPU heatsink with hardware	1.1	2.5
Intel® Value Solid State Drive, with interpose board and cable	TBD	TBD
RAID5 kit: RAID memory, hardware RAID key, cable for battery backup	0.34	0.75
RAID battery backup kit	0.23	0.50
Intel® Remote Management Module 2 (Intel® RMM2) - single pack	0.15	0.33
I/O module (four port external SAS)	0.11	0.25
I/O module (dual copper NIC ports)	0.11	0.25
TIGH2U bezel (unpainted)	0.34	0.75
SAS HDD carrier	0.11	0.25
Generic 2.5-inch hard disk drive	0.23	0.50
Generic DIMMs (quantity of 2)	0.11	0.25







## 3.0 Cables and Connectors

---

This chapter describes interconnections between the components of the Intel® Carrier Grade Server TIGH2U and provides overview diagrams and tables to describe the signals and pin-outs for the system connectors. See the *Intel® Server Board S5000PAL Technical Product Specification* or the system board sections of this manual for connector signal descriptions and pin-outs not listed in this section.

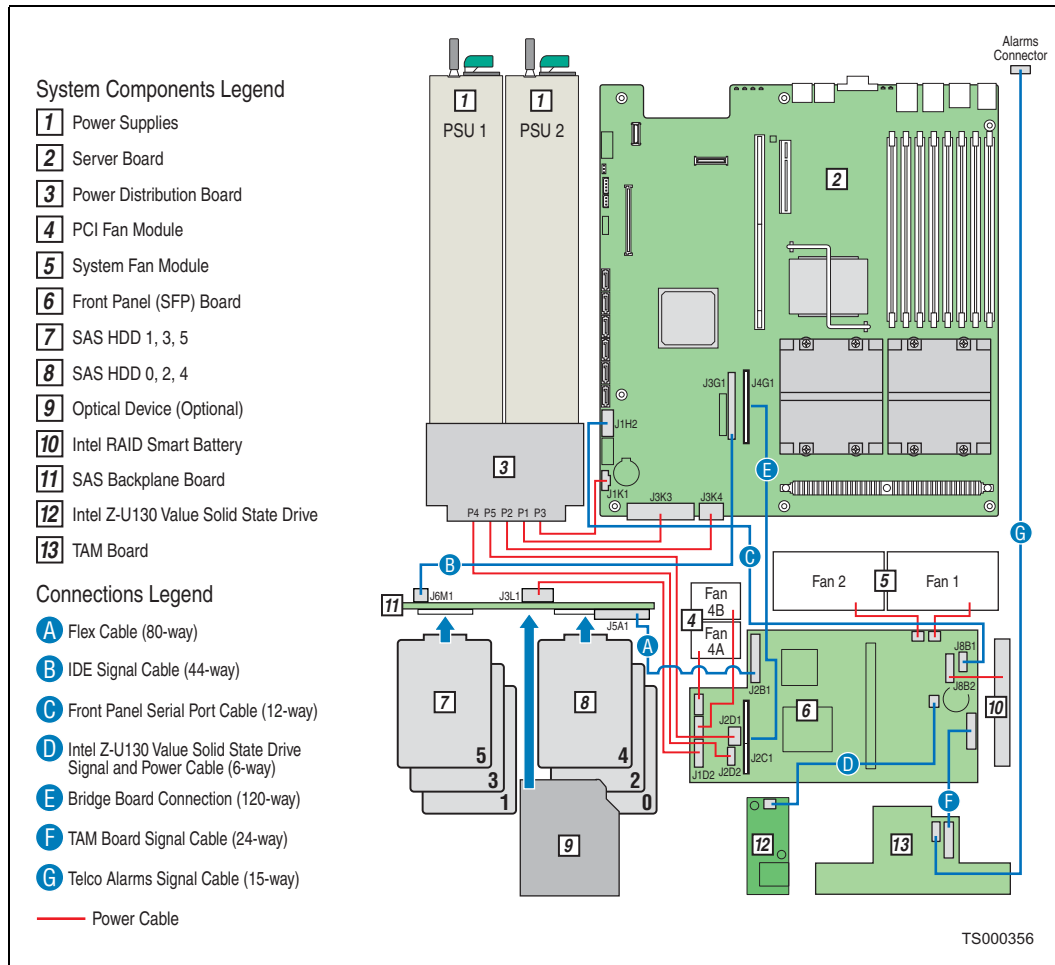
The information contained in this chapter is organized into the following sections:

- System Interconnect Block Diagram
- Cable and System Interconnect Descriptions
- User-Accessible Interconnects

### 3.1 System Interconnect Block Diagram

Figure 14 is a block diagram showing the interconnection of system components in the Carrier Grade Server TIGH2U.

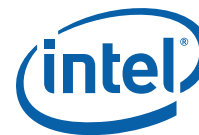
Figure 14. Carrier Grade Server TIGH2U System Interconnect Block Diagram



### 3.2 Cable and System Interconnect Descriptions

The Intel® Carrier Grade Server TIGH2U uses the following internal cables:

- Flex Circuit
- IDE Signal Cable
- SAS Backplane Power Cable
- TAM Board Signal Cable
- Telco Alarms Signal Cable
- Intel® Z-U130 Value Solid State Drive Signal and Power Cable
- SAS RAID Battery Power Cable
- Front Panel Serial Port Cable



### 3.2.1 Flex Circuit

The flex circuit is an impedance-controlled flexible circuit with 80 signal conductors that connects J5A1 on the SAS backplane and J2B1 on the SFP Board.

Figure 15 shows the flex circuit cable. Table 11 lists the pin-out for the SFP board connector.

Figure 15. Flex Circuit Cable

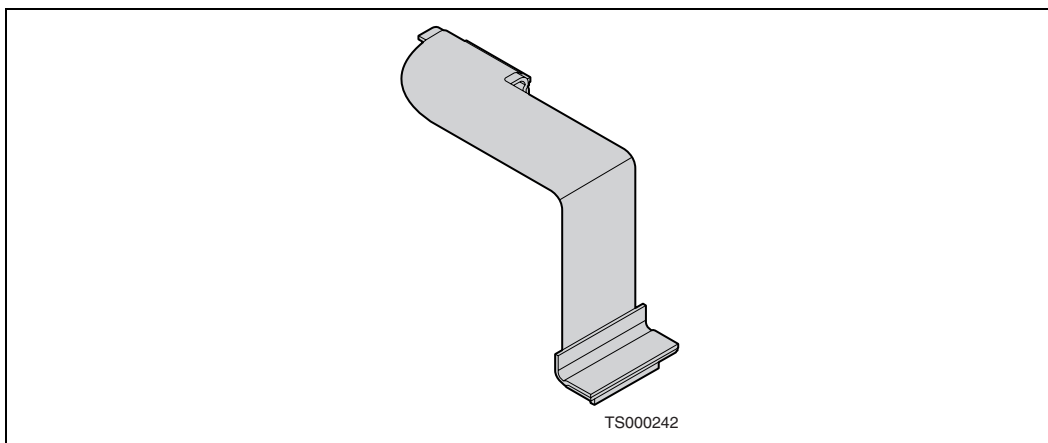


Table 11. Front Panel Flex Connector Pin-Out (Sheet 1 of 2)

Pin #	Front Panel Signal	Pin #	Front Panel Signal
1	FP_FLEX_PRE1	2	SMB_SAS_3V3_SCL
3	IPMB_I2C_SCL	4	SMB_SAS_3V3_SDA
5	IPMB_I2C_SDA	6	NC_FLEX_CONN_6
7	NC_FLEX_CONN_7	8	SGPIO_CLOCK_R
9	GND	10	SGPOI_LOAD_R
11	NC_SAS7_C_TX_N	12	GND
13	NC_SAS7_C_TX_P	14	GND
15	GND	16	NC_SAS7_C_RX_N
17	GND	18	NC_SAS7_C_RX_P
19	NC_SAS6_C_TX_P	20	SGPIO_DATAOUT0_R
21	NC_SAS6_C_TX_N	22	GND
23	GND	24	NC_SAS6_C_RX_N
25	GND	26	NC_SAS6_C_RX_P
27	SAS5_C_TX_N	28	SGPIO_DATAOUT1_R
29	SAS5_C_TX_P	30	GND
31	GND	32	SAS5_C_RX_N
33	GND	34	SAS5_C_RX_P
35	SAS4_C_TX_P	36	NC_FP_PWR_ENABLE
37	SAS4_C_TX_N	38	GND
39	GND	40	SAS4_C_RX_P

**Table 11. Front Panel Flex Connector Pin-Out (Sheet 2 of 2)**

Pin #	Front Panel Signal	Pin #	Front Panel Signal
41	GND	42	SAS4_C_RX_N
43	SAS3_C_TX_N	44	GND
45	SAS3_C_TX_P	46	GND
47	GND	48	SAS3_C_RX_N
49	GND	50	SAS3_C_RX_P
51	SAS2_C_TX_N	52	GND
53	SAS2_C_TX_P	54	GND
55	GND	56	SAS2_C_RX_N
57	GND	58	SAS2_C_RX_P
59	SAS1_C_TX_N	60	LED_HDD_ACT_R_L
61	SAS1_C_TX_P	62	GND
63	GND	64	SAS1_C_RX_N
65	GND	66	SAS1_C_RX_P
67	SAS0_C_TX_P	68	LED_HDD_FLT_R_L
69	SAS0_C_TX_N	70	GND
71	GND	72	SAS0_C_RX_N
73	NC_FLEX_CONN_73	74	SAS0_C_RX_P
75	NC_DIFF2_P	76	GND
77	NC_DIFF2_N	78	NC_FLEX_CONN_78
79	GND	80	FP_FLEX_PRES1

### 3.2.2 IDE Signal Cable

The IDE signal cable is a standard 2×22 position, 0.05 inch centers, 28 AWG ribbon cable that interconnects J3G1 on the Intel® Server Board T5000PAL and J6M1 on the SAS backplane for use by the optical drive.

Figure 16 illustrates the physical details of the cable assembly. Table 12 lists the pin-out for J3G1 connector on the server board.

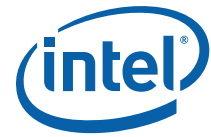


Figure 16. IDE Signal Cable Physical Details

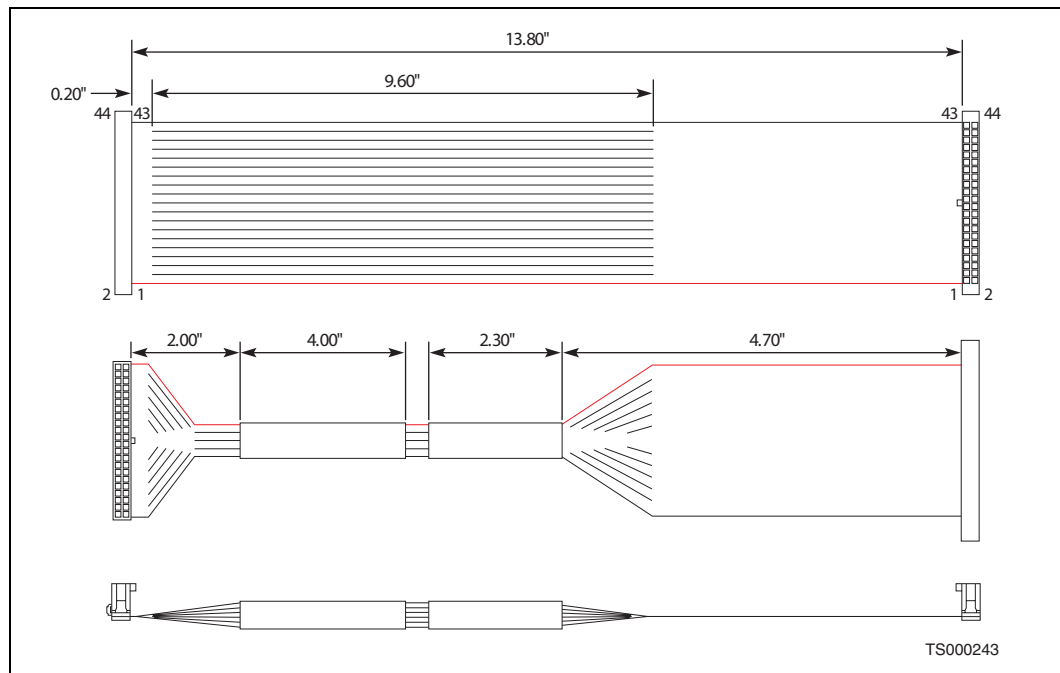


Table 12. IDE Signal Cable Connector J3G1 Pin-out

Pin #	Signal Name	Pin #	Signal Name
1	RST_IDE_L	2	GND
3	RIDE_DD <15..0> 7	4	RIDE_DD <15..0> 8
5	RIDE_DD <15..0> 6	6	RIDE_DD <15..0> 9
7	RIDE_DD <15..0> 5	8	RIDE_DD <15..0> 10
9	RIDE_DD <15..0> 4	10	RIDE_DD <15..0> 11
11	RIDE_DD <15..0> 3	12	RIDE_DD <15..0> 12
13	RIDE_DD <15..0> 2	14	RIDE_DD <15..0> 13
15	RIDE_DD <15..0> 1	16	RIDE_DD <15..0> 14
17	RIDE_DD <15..0> 0	18	RIDE_DD <15..0> 15
19	GND	20	NC
21	RIDE_DDREQ	22	GND
23	RIDE_DIOW_N	24	GND
25	RIDE_DIOR_N	26	GND
27	RIDE_DIORDY	28	IDE_CSEL
29	RIDE_DDACK_N	30	GND
31	IRQ_IDE	32	RIDE_P32
32	RIDE_P32	32	RIDE_P32
33	RIDE_DA1	34	IDE_PRI_CBLSNS
35	RIDE_DA0	36	RIDE_DA2

Table 12. IDE Signal Cable Connector J3G1 Pin-out (Continued)

Pin #	Signal Name	Pin #	Signal Name
37	RIDE_DCS1_N	38	RIDE_DCS3_N
39	LED_IDE_L	40	GND
41	NC_44P_IDE_P41	42	NC_44P_IDE_P42
43	NC_44P_IDE_P43	44	NC_44P_IDE_P44

### 3.2.3 SAS Backplane Power Cable

The SAS backplane power cable is a 2 x 6 20 AWG conductor discrete wire harness that connects J3L1 on the SAS backplane and J1D2 on the SFP Board.

Figure 17 shows the SAS backplane power cable. Table 13 gives the connector pin-out.

Figure 17. SAS Backplane Power Cable

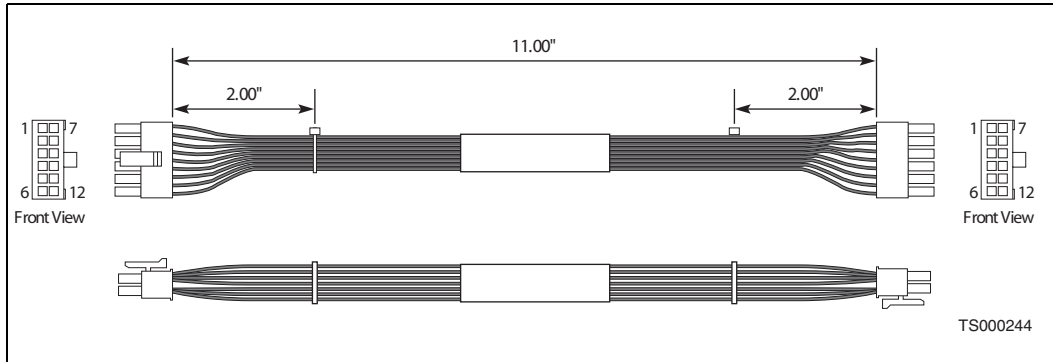


Table 13. SAS Backplane Power Cable Connections

Pin #	Signal	Wire Number	Pin #	Signal	Wire Number
1	PV5	1	7	P5V	2
2	PV5	3	8	P5V	4
3	P12V	5	9	P3V3	6
4	P12V	7	10	GND	8
5	GND	9	11	GND	10
6	GND	11	12	GND	12

### 3.2.4 TAM Board Signal Cable

The TAM board signal cable connects J8D1 on the SFP board to the SFP interface connector on the TAM board. Figure 18 shows the TAM board signal cable. Table 13 gives the connection information.



Figure 18. TAM Board Signal Cable

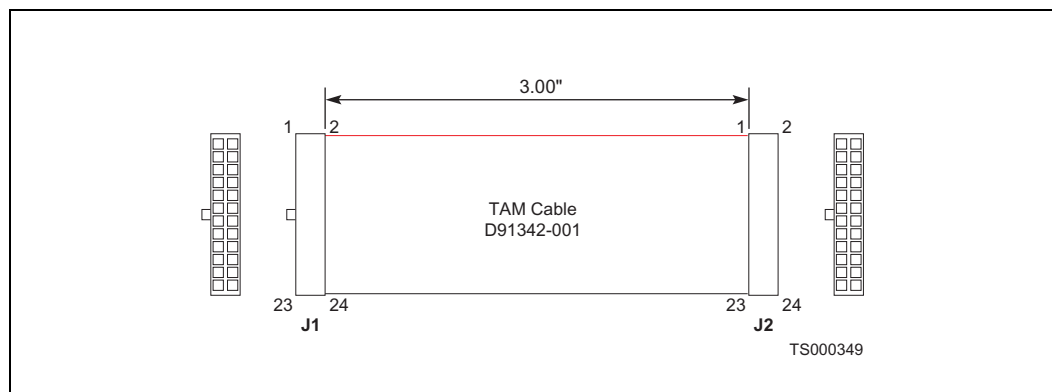


Table 14. TAM Board Signal Cable Connections

Pin	Signal	Pin	Signal
1	SMB_SENSOR_3V3SB_CLK_BUF	2	FP_PWR_BTN_N
3	SMB_SENSOR_3V3SB_DAT_BUF	4	FP_RST_BTN_N
5	N/C	6	FP_ID_BTN_N
7	FP_NIC_ACT_LED_N	8	FP_NMI_BTN_N
9	FP_PWR_LED_ON_N	10	N/C
11	N/C	12	HDD_ACT_LED
13	N/C	14	HDD_FLT_LED
15	FP_ID_LED_N	16	N/C
17	5V	18	5V STBY
19	5V	20	5V STBY
21	GND	22	GND
23	GND	24	GND

### 3.2.5 Telco Alarms Signal Cable

The alarm cable that routes the alarm relay contacts to the back of the chassis (see Section) contains a DB15 connector on one end and a 2 x 8 connector for interfacing to the alarms port connector on the TAM board.

Figure 19 shows the TAM board signal cable. Table 15 shows the pinout for both the 2 x 8 connector on the TAM board and the DB15 connector on the back of the system.

Figure 19. Telco Alarms Signal Cable

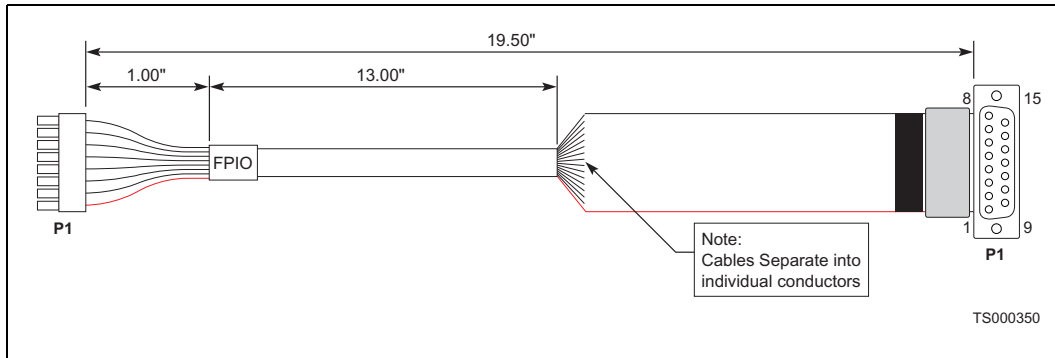
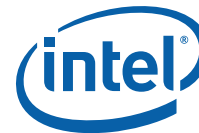


Table 15. Alarms Connection Pinout

2 x 8 Connector on TAM Board Pin	Signal	DB-15 Connector on Back of System Pin
1	Minor reset positive	1
3	Minor reset negative	2
5	Major reset positive	3
7	Major reset negative	4
9	Critical alarm normally open	5
11	Critical alarm normally closed	6
13	Critical alarm common	7
15	Minor alarm normally open	8
2	Minor alarm normally closed	9
4	Minor alarm common	10
6	Major alarm normally open	11
8	Major alarm normally closed	12
10	Major alarm common	13
12	Power alarm normally open	14
14	Power alarm common	15
16	No connection	





### 3.2.6 Intel® Z-U130 Value Solid State Drive Signal and Power Cable

The optional Intel® Z-U130 Value Solid State Drive connects to the SFP board with a single signal and power cable. The physical details of this cable are shown in Figure 20 (all dimensions in inches), and the pin-out of the connectors is given in Table 16.

Figure 20. Intel® Z-U130 Value Solid State Drive Signal and Power Cable Physical Details

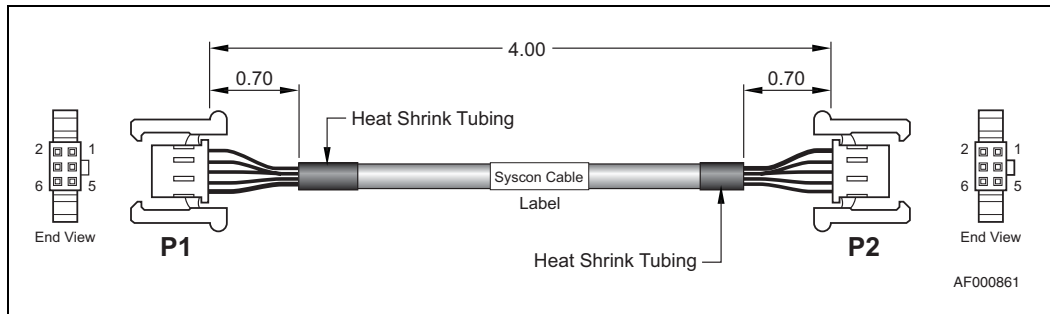


Table 16. Intel® Z-U130 Value Solid State Drive 2 X 3 Connector Pin-Out

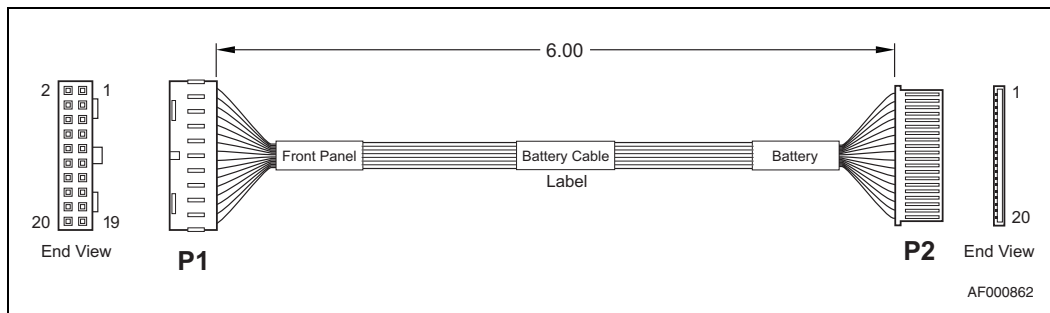
Pin #	Signal
1	GND
2	Keyed (no connect)
3	SYSCON_USB_P
4	SYSCON_PWR
5	SYSCON_USB_N
6	GND

### 3.2.7 SAS RAID Battery Power Cable

The SAS RAID battery power cable connects J8B2 on the SFP board to the corresponding connector on the Intel® RAID Smart Battery.

Figure 21 shows the SAS RAID battery power cable (all dimensions are given in inches). Table 17 gives the connection for the 1 x 20 connector (P2).

Figure 21. SAS RAID Battery Power Cable Physical Details



**Table 17. Battery Backup Unit Power Cable Connector**

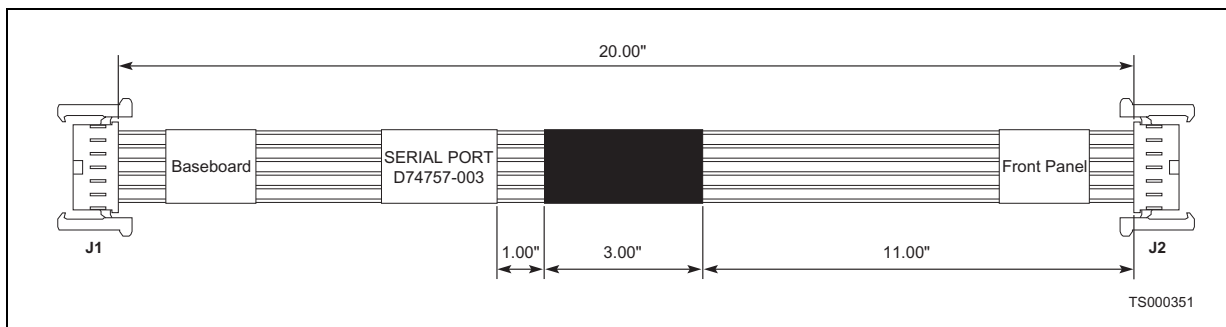
Pin #	Signal Name
1	12V
3	NC
2	GND
4	GND
5	VBAT_RAID
6	GND
7	3.3V
8	GND
9	VBAT_RAID
10	GND
11	RESET_N
12	GND
13	SCK
14	GND
15	SDA
16	PFAIL_N
17	DDR_SEL
18	BBE
19	BBSTROBE
20	STATUS

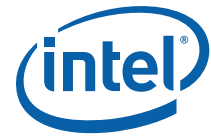
### 3.2.8 Front Panel Serial Port Cable

The front panel serial port cable connects J1H2 on the Intel® Server Board T5000PAL to J8B1 on the SFP board.

Figure 22 shows the front panel serial port cable. Table 18 gives the cable connector pin-out.

**Figure 22. Front-Panel Serial Port Cable Physical Details**





**Table 18. Front Panel Serial Cable Connections**

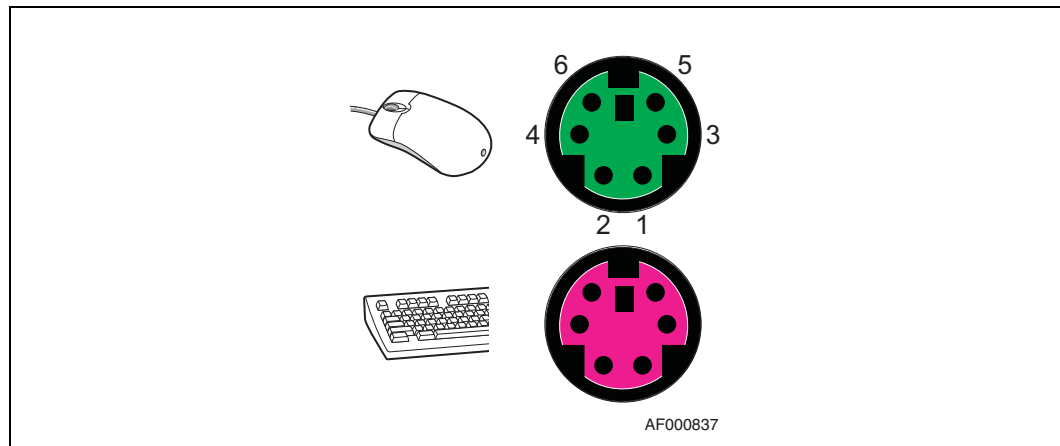
Pin #	Signal Name	Pin #	Signal Name
1	EMP_DCD_L	2	EMP_DSR_N
3	EMP_SIN	4	EMP_RTS_N
5	EMP_SOUT	6	EMP_CTS_N
7	EMP_DTR_N	8	NC_EMP_RI_N
9	EMP_INUSE_L	10	NC_5V_STBY
11	GND	12	NC (key)

### 3.3 User-Accessible Interconnects

#### 3.3.1 Keyboard and Mouse Ports

Two stacked PS/2 ports are provided to support both a keyboard and a mouse. Each port can support either a mouse or keyboard. Table 19 details the pin-out of the PS/2 connectors.

**Figure 23. Keyboard and Mouse Connectors**



**Table 19. Keyboard and Mouse Port Pin-Out**

Pin #	Signal
1	KEYDAT (keyboard data)
2	MSEDAT (mouse data)
3	GND (ground)
4	Fused Vcc (+5V)
5	KEYCLK (keyboard clock)
6	MSECLK (mouse clock)

### 3.3.2 Serial Port B

Two serial port connectors are provided, one on the front panel and one at the rear I/O, both using 8-pin RJ45 connectors. Both the front and rear serial port connectors connect to COM2. The user may connect to either the front or the rear serial port connector, but never to both. Figure 24 shows the serial port connector. Table 20 gives the pinout for the rear panel port and Table 21 gives the pinout of the front panel port.

An RJ45 connector provides a convenient connection to serial port concentrators, which typically use RJ45 connectors. For applications that require a DB-9 serial port connection, an adapter cable must be used.

The connector pin-out differs slightly between the front-panel and rear-panel connectors, specifically in relation to Pin 5 and Pin 7. On the front-panel serial port connector, Pin 5 is used as a serial port selection input. Grounding the EMP\_INUSE\_L signal that appears on Pin 5 disables the rear-panel serial port connection so that only the front-panel connection is active. This feature allows users to plug into and use the front-panel connector without regard for whether anything is connected to the rear-panel connector.

On the rear-panel serial port connector, Pin 7 can be configured by a jumper on the server board to carry either the DSR (Data Set Ready) signal or the DCD (Data Carrier Detect) signal as required by a particular serial port concentrator. (The front-panel serial port connector always carries the DSR signal on Pin 7.) The default jumper configuration selects the DSR signal, which conforms to the Cisco\* serial port standard. See the *Intel® Server Board S5000PAL Technical Product Specification* for details about this jumper or if you need to change the DSR / DCD configuration.

Figure 24. Serial Port Connector

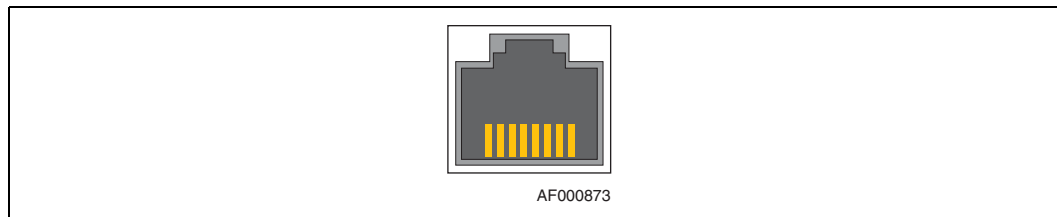
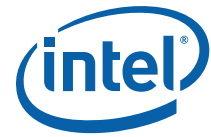


Table 20. Rear Panel Serial Port (RJ45) Connector Pinout

Pin #	Signal	Description
1	RTS	Request To Send
2	DTR	Data Terminal Ready
3	TXD	Transmit Data
4	GND	
5	RI	Ring Indicator
6	RXD	Receive Data
7†	DSR or DCD	Data Set Ready or Data Carrier Detect
8	CTS	Clear to Send
<b>Note:</b> † A jumper block on the server board determines whether DSR or DCD is routed to pin 7. The server board has the jumper block preconfigured with DSR enabled.		



The front panel board includes an RJ45 connector, which is the COM2 port. This RJ45 connector is accessible from behind the front bezel.

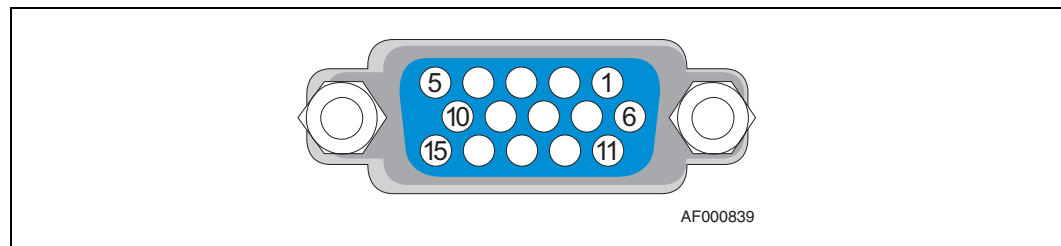
**Table 21. Front Panel Serial Port (RJ45) Connector Pinout**

Pin #	Signal	Description
1	RTS	Request To Send
2	DTR	Data Terminal Ready
3	TXD	Transmit Data
4	GND	Ground
5	In Use	When grounded, indicates that the COM2 port is routed to the front panel RJ45 connector.
6	RXD	Receive Data
7	DSR	Data Set Ready
8	CTS	Clear to Send

### 3.3.3 Video Port

The video port interface is a standard VGA-compatible, 15-pin connector. On-board video is supplied by an ATI\* Rage XL video controller with 16 Mbytes of on-board video SGRAM. Figure 25 shows the video connector and Table 22 gives the pinout.

**Figure 25. Video Connector**



**Table 22. Video Connector Pin-Out**

Pin #	Signal
1	Red (analog color signal R)
2	Green (analog color signal G)
3	Blue (analog color signal B)
4	No connection
5	GND
6	GND
7	GND
8	GND
9	Fused Vcc (+5V)
10	GND
11	No connection
12	DDCDAT

**Table 22. Video Connector Pin-Out (Continued)**

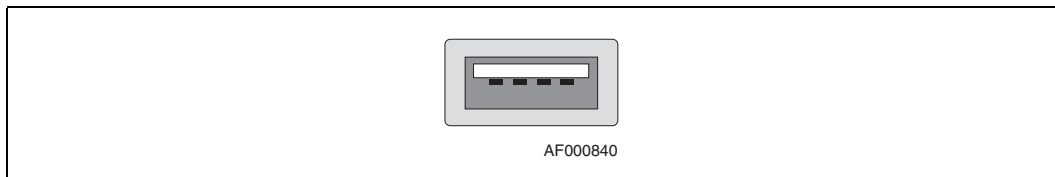
13	HSYNC (horizontal sync)
14	VSYNC (vertical sync)
15	DDCCLK

### 3.3.4 Universal Serial Bus (USB) Interface

The Intel® Server Board T5000PAL provides USB port support. USB ports 0 and 1 are brought out at the rear of the unit on the server board, and USB ports 2 and 3 are routed to the SFP board. USB port 2 is brought to the front of the system and is accessible. USB port 3 is used internally for interfacing to the Intel® Value Solid State Drive.

The built-in USB ports permit direct connection of up to three USB peripherals without the need for an external hub. If more devices are required, an external hub can be connected to any of the built-in ports. Figure 26 shows an external USB connector and Table 23 gives the pinout.

**Figure 26. External USB Connector**



**Table 23. USB Connector Pin-Out**

Pin #	Signal
1	Fused Vcc (+5V with over-current monitor of ports 0, 1, 2, and 3)
2	DATAL0 (differential data line paired with DATAH0)
3	DATAH0 (differential data line paired with DATAL0)
4	GND

### 3.3.5 Ethernet Connectors

The Intel® Server Board T5000PAL provides two NIC RJ45 connectors oriented side by side on the back edge of the board and accessible at the rear I/O panel. Figure 27 shows the Ethernet connector and Table 24 gives the pinout, which is identical for each connector.

For each Ethernet connector there are two status indicator LEDs integrated in the same assembly as the connector itself, a green LED to the left of the connector and a bi-color LED to the right of the connector.

The green LED indicates the connection status for each port. If the port is connected to a network but there is no current activity, the green LED is continuously illuminated. When there is activity on the connected network the green LED blinks.

The bi-color LED indicates the connection speed of the network connection. If the bi-color LED is not lit but the green LED is either lit or blinking, the port's connection speed is 10 Mbps. If the bi-color LED shows a solid green indication, the port's connection speed is 100 Mbps. If the bi-color LED shows a solid amber indication, the port's connection speed is 1 Gbps.



Figure 27. Ethernet Connectors

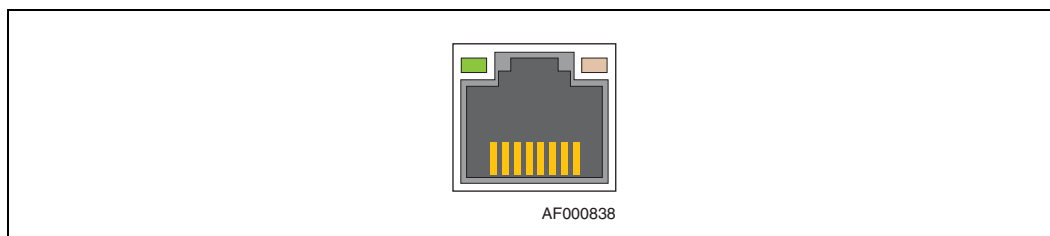


Table 24. Ethernet Connector Pin-Out

Pin #	Signal Name	Description
1	BI_DA+	Bi-directional pair A, +
2	BI_DA-	Bi-directional pair A, -
3	BI_DB+	Bi-directional pair B, +
4	BI_DC+	Bi-directional pair C, +
5	BI_DC-	Bi-directional pair C, -
6	BI_DB-	Bi-directional pair B, -
7	BI_DD+	Bi-directional pair D, +
8	BI_DD-	Bi-directional pair D, -

### 3.3.6 External SAS 4X Hard Disk Drive Connector

The Carrier Grade Server TIGH2U provides an external SAS 4X hard drive connector. The SAS 4X external connector is illustrated in Figure 28, and the pin-out for the connector is shown in Table 25.

Figure 28. External SAS 4X Hard Disk Drive Connector

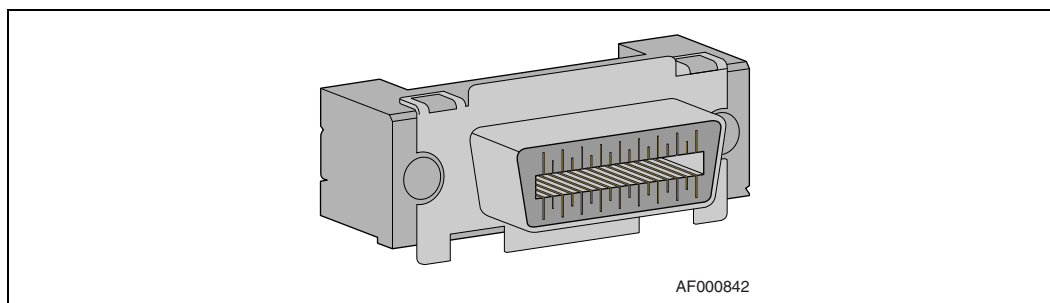


Table 25. External SAS 4X Hard Disk Drive Connector Pin-Out

Pin	Signal	Pin	Signal
S1	SAS_RX4_P	S2	SAS_RX4_N
S3	SAS_RX5_P	S4	SAS_RX5_N
S5	SAS_RX6_P	S6	SAS_RX6_N
S7	SAS_RX7_P	S8	SAS_RX7_N
S9	SAS_TX7_N	S10	SAS_TX7_P

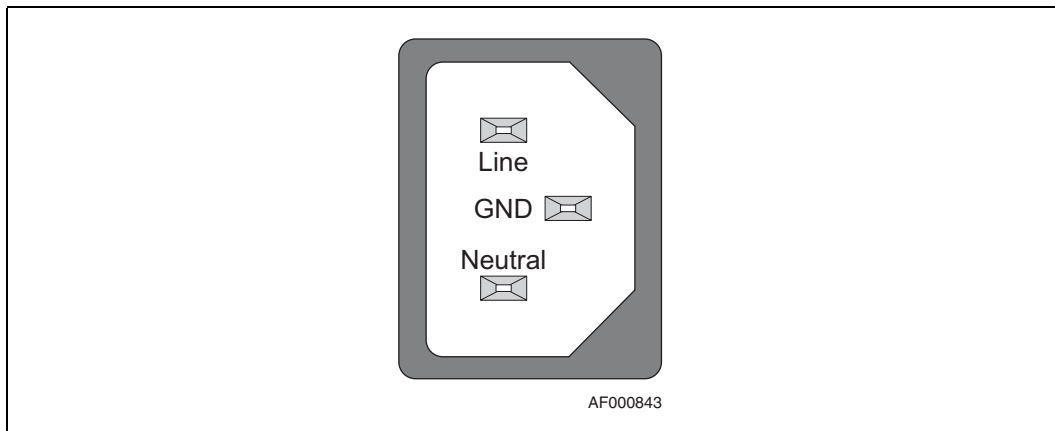
**Table 25. External SAS 4X Hard Disk Drive Connector Pin-Out (Continued)**

Pin	Signal	Pin	Signal
S11	SAS_TX6_N	S12	SAS_TX6_P
S13	SAS_TX5_N	S14	SAS_TX5_P
S15	SAS_TX4_N	S16	SAS_TX4_P
G1	GND	G2	GND
G3	GND	G4	GND
G5	GND	G6	GND
G7	GND	G8	GND
G9	GND		

### 3.3.7 AC Power Input for AC-Input Power Supply

One IEC320-C13 receptacle is provided at the rear of each AC-input power module. An appropriately sized power cord and AC main must be used. See Chapter 9.0, “Power Subsystem”, for system voltage, frequency, and current draw specifications.

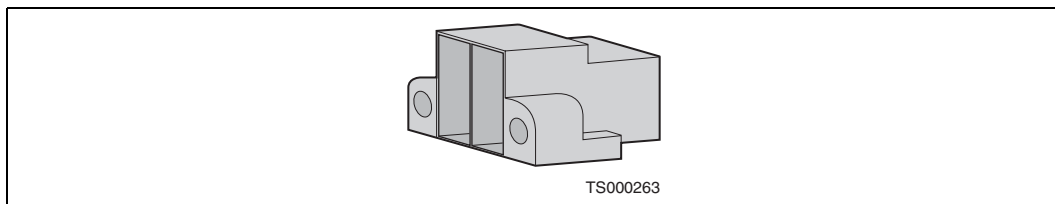
**Figure 29. AC Power Input Connector**



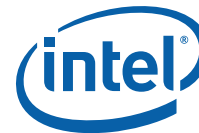
### 3.3.8 DC Power Input for DC-Input Power Supply

A pluggable DC power terminal block provides the DC-input power connection to each of the DC-input power supply modules that are configured in the DC power supply cage. It is recommended to use appropriately sized power wire and DC main. See Chapter 9.0, “Power Subsystem” for system DC voltage and current draw specifications.

**Figure 30. DC Power Input Connector**







### 3.3.9 Alarms Connector

A optional DB-15 connector at the rear of the chassis provides connections to the alarm relays on the TAM board that are triggered when a critical, major, minor or power alarm is present in the system. Figure 31 shows the Alarms connector and Table 26 gives the pin-out.

Figure 31. Alarms Connector

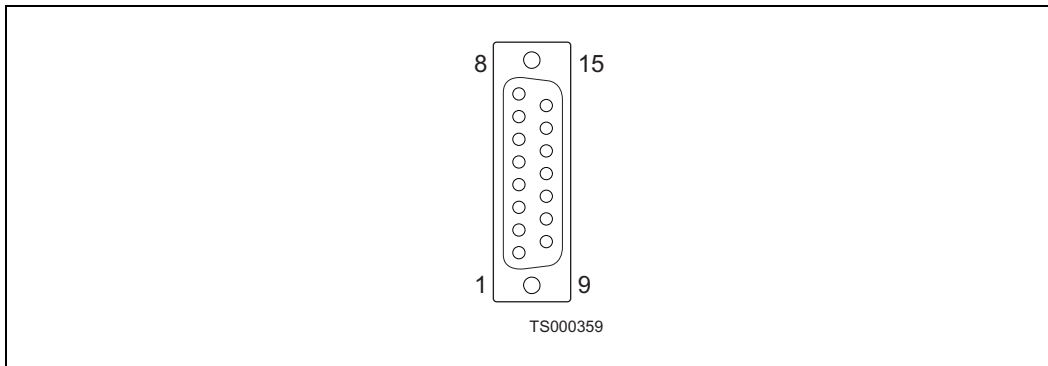


Table 26. Alarms Connector Pin-Out

Pin	Signal	Pin	Signal
8	Minor alarm normally open	15	Power alarm common
7	Critical alarm common	14	Power alarm normally open
6	Critical alarm normally closed	13	Major alarm common
5	Critical alarm normally open	12	Major alarm normally closed
4	Major reset negative	11	Major alarm normally open
3	Major reset positive	10	Minor alarm common
2	Minor reset negative	9	Minor alarm normally closed
1	Minor reset positive		





## 4.0 SAS Front Panel (SFP) Board

---

This chapter describes the basic functions and interface requirements of the SAS Front Panel (SFP) system board designed for the Intel® Carrier Grade Server TIGH2U.

This chapter is organized in the following sections:

- Features
- Overview
- Component Location
- Power Distribution
- I/O Processor Subsystem
- SAS Controller (LSISAS1068)
- Clock Generation / Distribution
- Programmable Logic Device (PLD)
- Hardware RAID
- Software RAID
- Debug Features
- Power Good Circuit
- Reset Control
- Connector Information

### 4.1 Features

SFP board features include:

- One RS-232 front panel port
- One USB 2.0 front panel port
- One USB 2.0 interface to the Intel® Value Solid State Drive, which provides local memory storage
- One flex cable connection to the SAS backplane to support the interface to six independent 2.5-inch SAS hard drives
- One socket for a hardware RAID key, required to enable hardware RAID
- One socket for a DDR2 mini-DIMM that provides data caching for hardware RAID
- One connector for the Intel® RAID Smart Battery that allows the contents of the DDR2 mini-DIMM to be preserved if power falls below specifications.
- Four fan connectors to provide power, control, and monitoring for the four cooling fans
- Four fan fault LEDs (not visible on front panel; for diagnostics purposes only)



## 4.2 Overview

The SAS front panel (SFP) provides SAS support and provides support for hardware RAID 0 / 1 / 10 / 5 and software RAID 0 / 1 / 10.

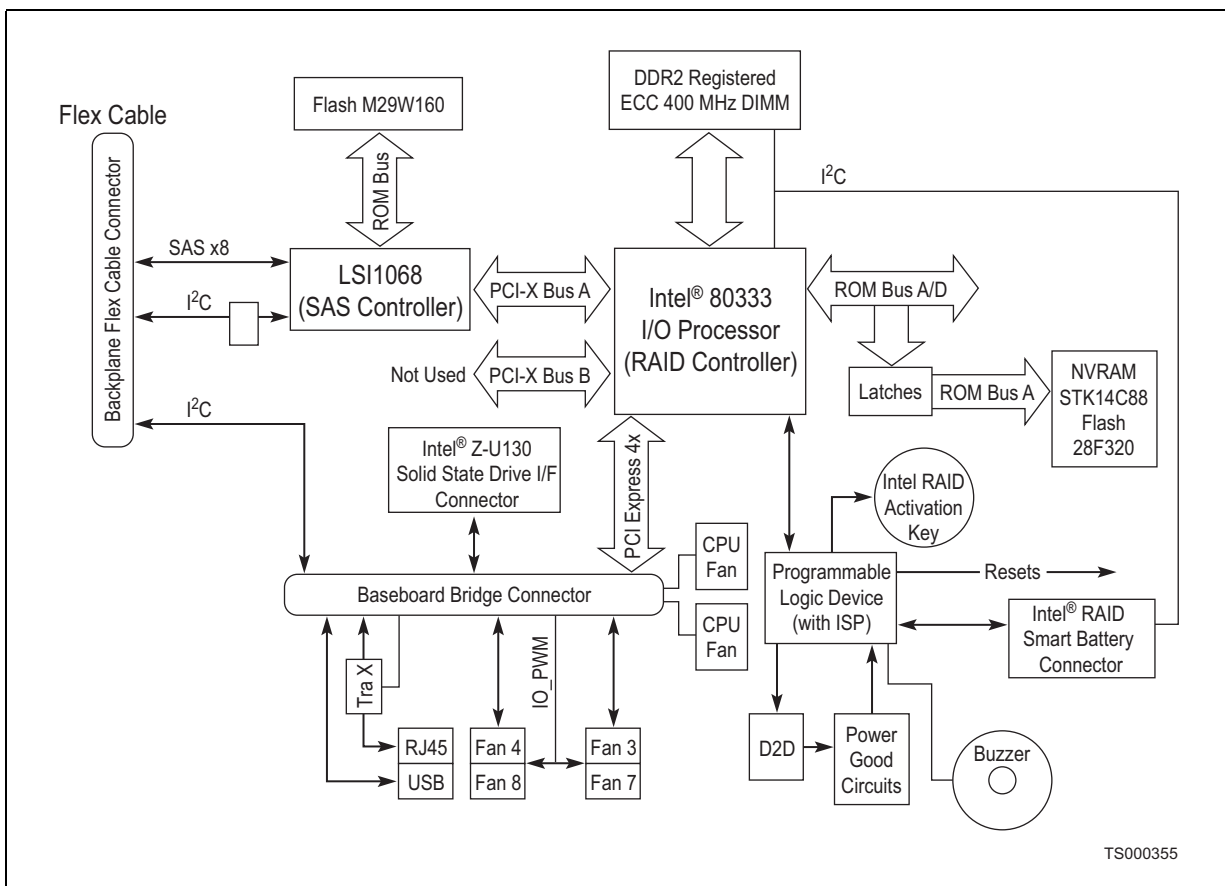
The TIGH2U SFP provides the following main categories of functions for the system:

- Cascaded power conversion
  - +12V to +1.8V
  - +12V to +1.5V
  - +1.8V to +1.2V
  - +3.3V to +1.35V
  - 5V\_stby to 3.3V\_stby
  - 5V\_stby to VbatRaid
  - +1.8V to VbatRaid
- Six SAS ports (to SAS backplane)
  - 3.0 Gbps link rate
  - 1.5 Gbps link rate
  - SFF-8470 compliant connector
- RAID 0 / 1 / 10 support
  - LSI Logic\* LSISAS1068, which provides RAID 0 / 1 / 10
- RAID 5 support
  - hardware support via the Intel® 80333 I/O processor device
  - Intel® RAID Smart Battery connector; provides power for DIMM in the case of power failure
  - hardware RAID key socket; a hardware RAID key is required to enable RAID 5 support
  - DDR2 SDRAM DIMM socket; supports up to 1 Gbyte memory modules
- Buzzer
  - audible indication of drive failure

Figure 32 presents the functional block diagram of the SAS front panel board.



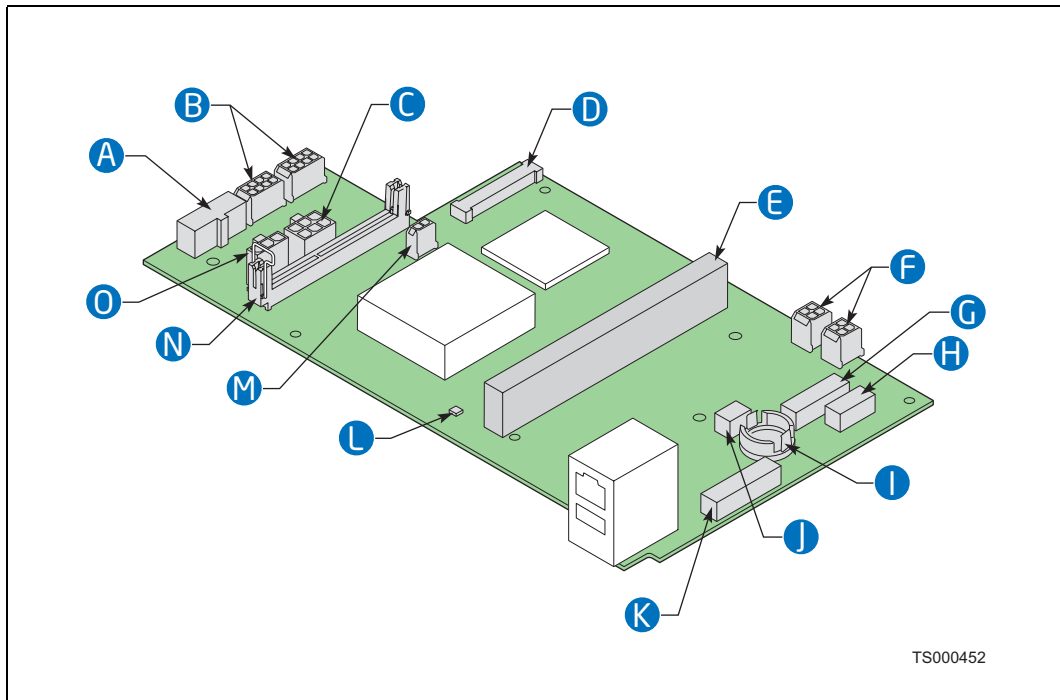
Figure 32. SAS Front Panel Board Functional Block Diagram



### 4.3 Component Location

Figure 33 shows the placement of the major components and connectors on the SFP board. Figure 34 show the locations of front panel LED indicators, switches and connectors.

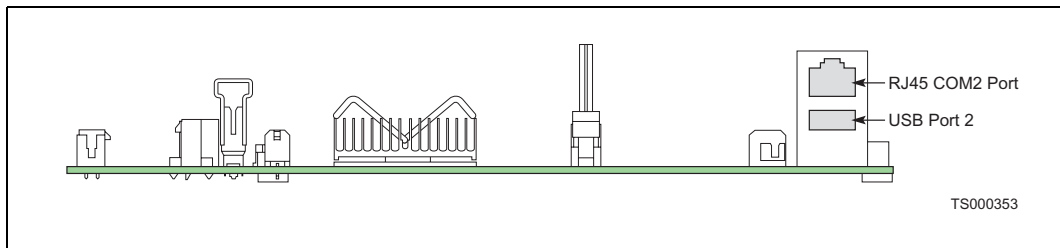
Figure 33. SFP Board Component Locations



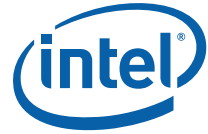
TS000452

Item	Description	Item	Description
A	SAS Power Connector	I	Intel® RAID Activation Key Socket
B	PCI Fan Connectors	J	Intel® Value Solid State Drive Connector
C	PS Power Connector	K	TAM Interface Connector
D	Flex Circuit Connector	L	Thermal Sensor
E	RAID Mini-DIMM Socket	M	Standby Power Connector
F	CPU Fan Connectors	N	Bridge Board Connector
G	Intel® RAID Smart Battery Connector	O	PS Power Connector
H	Serial Connector		

Figure 34. SFP Board Front View



TS000353



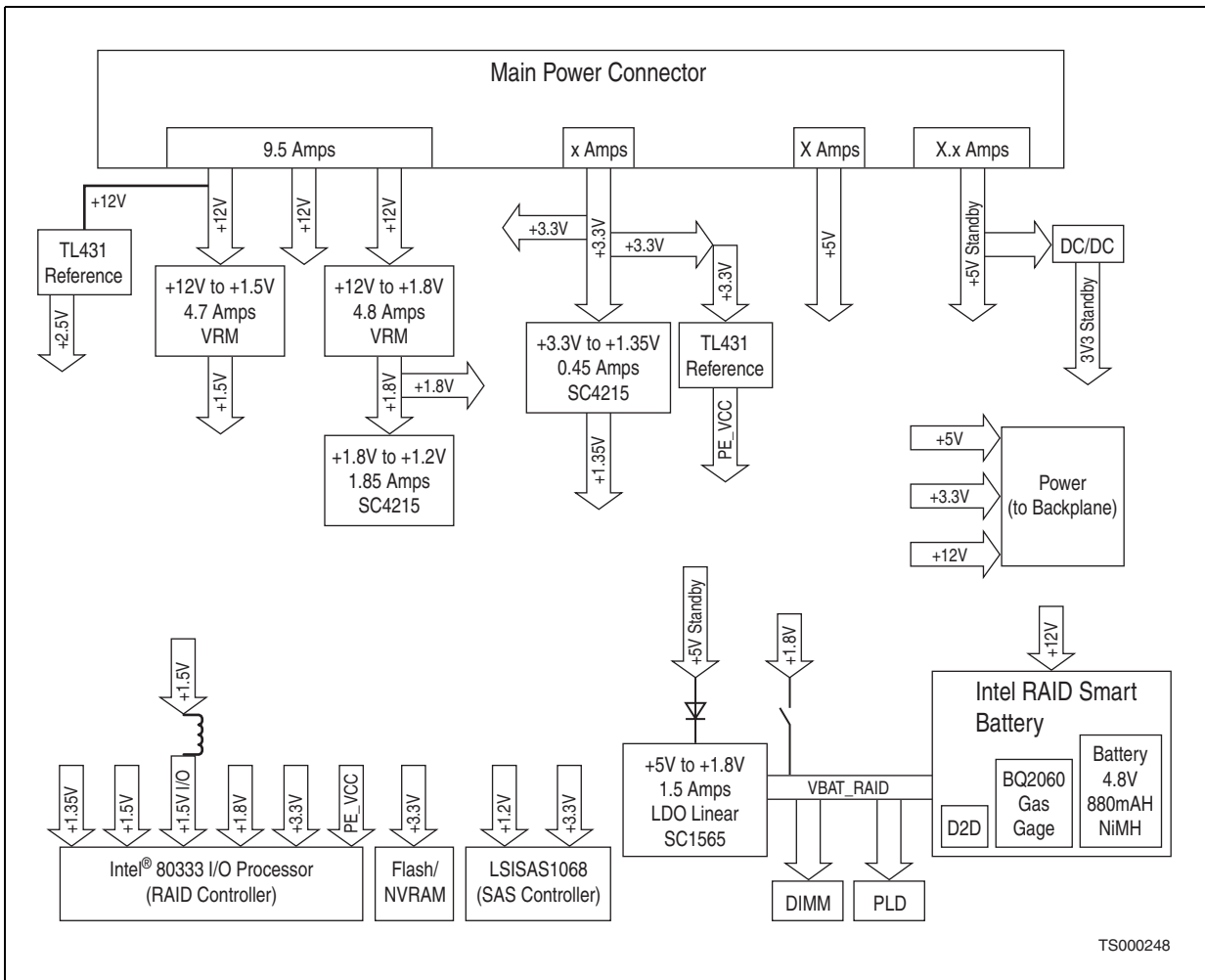
### 4.4 Power Distribution

This section details the SFP power distribution. This consists of power provided by the power distribution board (PDB) and the D2D and linear on-board regulators:

- the +12 V board input is cascaded to +1.8 V, +1.5 V, +1.35 V, +1.2 V and passed through to the backplane.
- the +3.3 V board input is converted to +1.35 V and passed through to the backplane.
- the +5 V\_Standby board input is converted to +3 V\_Standby and VBAT\_RAID (1.8 V\_Standby).
- the +5 V board input is passed through to the backplane.

Figure 35 shows the power conversion and distribution functions.

**Figure 35. SFP Board Power Conversion**





#### 4.4.1 Battery Backup Power Control

The battery backup power controller determines the appropriate source for the VBAT\_RAID power rail from several possible sources, and activates that source according to the following rules:

- During normal operation, the 1.8 V power rail supplies VBAT\_RAID.
- If main system power is turned off and standby power is available, the 5 V to 1.8 V linear regulator supplies VBAT\_RAID.
- If all system power fails and the DDR DIMM has critical data stored, the Intel® RAID Smart Battery supplies VBAT\_RAID.

#### 4.4.2 12 V to 1.8 V VRM

The 12 V to 1.8 V VRM converts the +12 V supply to +1.8 V. The generated +1.8 V is used by the Intel® 80333 I/O processor, LSISAS1068, DDR2, and PLD.

- Output rated at +1.8 V  $\pm$ 2% at a maximum of 6 A continuous
- Over-current protection
- Voltage regulation starts when the input voltage exceeds  $\sim$ 7.9 V
- DOSA standard footprint
- D2D can be inhibited with the ENABLE\_P1V8\_N signal (controlled by the PLD)

#### 4.4.3 12 V to 1.5 V VRM

The 12 V to 1.5 V VRM converts the +12 V supply to +1.5 V. The generated +1.5 V is used by the Intel® 80333 I/O processor.

- Output rated at +1.5 V  $\pm$ 2% at a maximum of 6 A continuous
- Over-current protection
- Voltage regulation starts when the input voltage exceeds  $\sim$ 7.9 V
- DOSA standard footprint
- D2D can be inhibited with the ENABLE\_P1V5\_N signal (controlled by the PLD)

#### 4.4.4 3.3 V to 1.35 V DC-to-DC Linear Converter

The 3.3 V to 1.35 V D2D converts the +3.3 V supply to +1.35 V. The generated +1.35 V is used by the Intel® 80333 I/O processor.

- Output rated at +1.35 V  $\pm$ 2% at a maximum of 3 A continuous
- Over current and over temperature protection
- D2D can be inhibited with the P1V35\_ENABLE\_N signal (controlled by the PLD)

#### 4.4.5 1.8 V to 1.2 V DC-to-DC Linear Converter

The 1.8 V to 1.2 V D2D converts the +1.8 V supply to +1.2 V. The generated +1.2 V is used by the LSISAS1068.

- Output rated at +1.2 V  $\pm$ 2% at a maximum of 3 A continuous
- Over current and over temperature protection
- D2D can be inhibited with the P1V2\_ENABLE\_N signal (controlled by the PLD)





## 4.5 I/O Processor Subsystem

This section provides a detailed description of the Carrier Grade Server TIGH2U SFP board I/O processor (Intel® 80333 I/O processor) subsystem. The I/O Processor subsystem has two major functions:

- Acts as a PCI-X\* to PCI Express\* bridge
- Provides RAID 5 functionality

### 4.5.1 PCI-X to PCI Express Bridge

The Intel® 80333 I/O processor acts as PCI-X to PCI Express bridge. This allows the SFP board to attach to the server board's PCI Express interface and use existing PCI-X SAS controllers.

### 4.5.2 RAID Controller

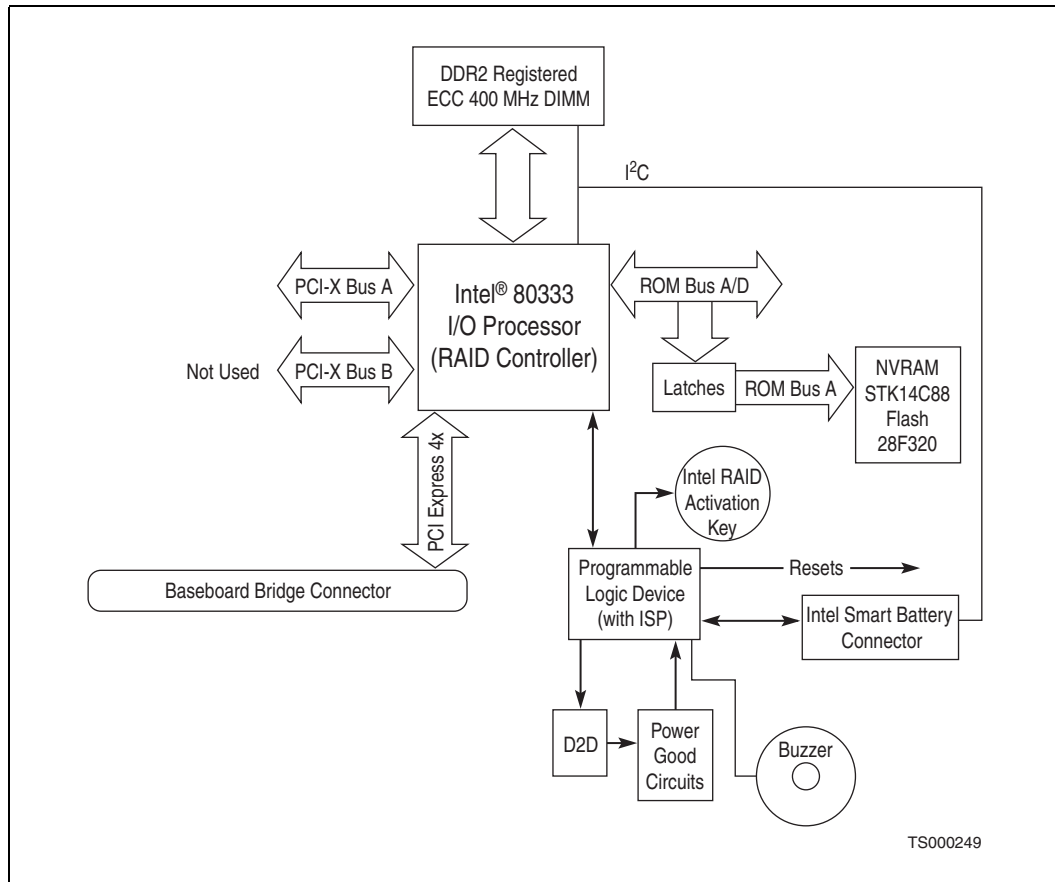
The Intel® 80333 I/O processor adds hardware RAID capabilities to the Carrier Grade Server TIGH2U SFP board.

When in RAID mode, the following parts of the I/O processor subsystem interact:

- DDR2
- Intel® 80333 I/O processor
- Flash memory
- Intel® RAID Activation Key
- PCI-X buses

The following topics describe each part and its role.

Figure 36. I/O Subsystem Block Diagram



### 4.5.3 Intel® 80333 I/O Processor

The Carrier Grade Server TIGH2U SFP architecture is based around the Intel® 80333 I/O processor. The 500 MHz core of the 80333 processor controls:

- Two 133 MHz, 64-bit, PCI-X buses
- A x8 PCI Express interface
- A ROM bus
- A DDR2, 400 MHz SDRAM bus

The 80333 processor also provides two UARTs, I<sup>2</sup>C bus, and GPIOs.

In PCI-X to PCI Express bridge mode, the 80333 processor is seen by the system as a bridge. This allows the LSISAS1068 to provide SAS support and software RAID support for the system.

In hardware RAID mode, the 80333 processor provides transparent hardware support for RAID 0 / 1 / 10 / 5. The 80333 processor provides virtual disk arrays for the system to use. These disk arrays can be in any of the supported RAID modes. The 80333 processor's DDR2 connector provides flexible cache support. The cache support can speed up transaction timing, depending on the cache configuration. When in RAID mode, the 80333 processor boots from flash memory and loads configuration information from the NVRAM.



#### 4.5.4 Flash Memory

A 32-Mbit flash memory component contains the executable code for the 80333 processor and is only used when the 80333 processor is in hardware RAID 5 mode.

#### 4.5.5 NVRAM

The NVRAM is 256 Kbits of accessible static RAM. The NVRAM stores the 80333 processor's configuration information and disk drive RAID configuration information.

#### 4.5.6 PCI-X Buses

The PCI-X bus interface is 64 bits and runs at 133 MHz. Only one of the 80333 processor's PCI-X buses is used. The LSISAS1068 is the only device on the 80333 processor's PCI-X bus.

#### 4.5.7 PCI Express Bus

The PCI Express bus interfaces the 80333 processor to the system via the baseboard bridge adapter. The PCI Express bus is a x4 configuration. The 80333 processor also supports x1 and x8 modes.

#### 4.5.8 DDR2 Bus

The 80333 processor's DDR2 bus runs at 400 MHz and supports 256 Mbit, 512 Mbit, and 1 Gbit registered DIMMs. The DDR2 bus provides data caching when the 80333 processor is operating in hardware RAID mode.

#### 4.5.9 Intel<sup>®</sup> RAID Smart Battery

The battery backup allows the contents of the DIMM to be preserved if power drops below specifications. The DIMM uses the VBAT\_RAID 1.8V supply as supplied by either P1V8, P5\_STBY, or the Intel<sup>®</sup> RAID Smart Battery (battery backup module).

Under normal operation, full power (P1V8) is applied to VBAT\_RAID and is converted from 12 V to 1.8 V by a separate PWM-controlled switching regulator. If this rail drops out, VBAT\_RAID is powered from the system power supply standby rail (P3V3\_STBY) through an SC1565 LDO regulator. If P3V3\_STBY\_PWRGD is deasserted, the Intel RAID Smart Battery takes over as the VBAT\_RAID source (if cache data is present in the DIMM).

When the 80333 processor senses power has dropped below 2.96 V (Powergood deasserts) and its POWER\_DELAY signal is asserted, it initiates a power fail sequence that safely puts the ROMB DIMM into self-refresh state. The POWER\_DELAY circuit generates enough of a delay to allow the 80333 processor to complete its power fail sequence. After the power fail sequence completes, additional logic (powered by VBAT\_RAID) holds the DIMM's clock enable signals low to keep the DIMM in self-refresh mode. Once power is restored, data from the DIMM can be written to the disk array.

#### 4.5.10 GPIOs

The 80333 processor has eight GPIOs that handle various input and output functions. The GPIOs are used to control the Intel<sup>®</sup> RAID Smart Battery, system indicators, and debug support.

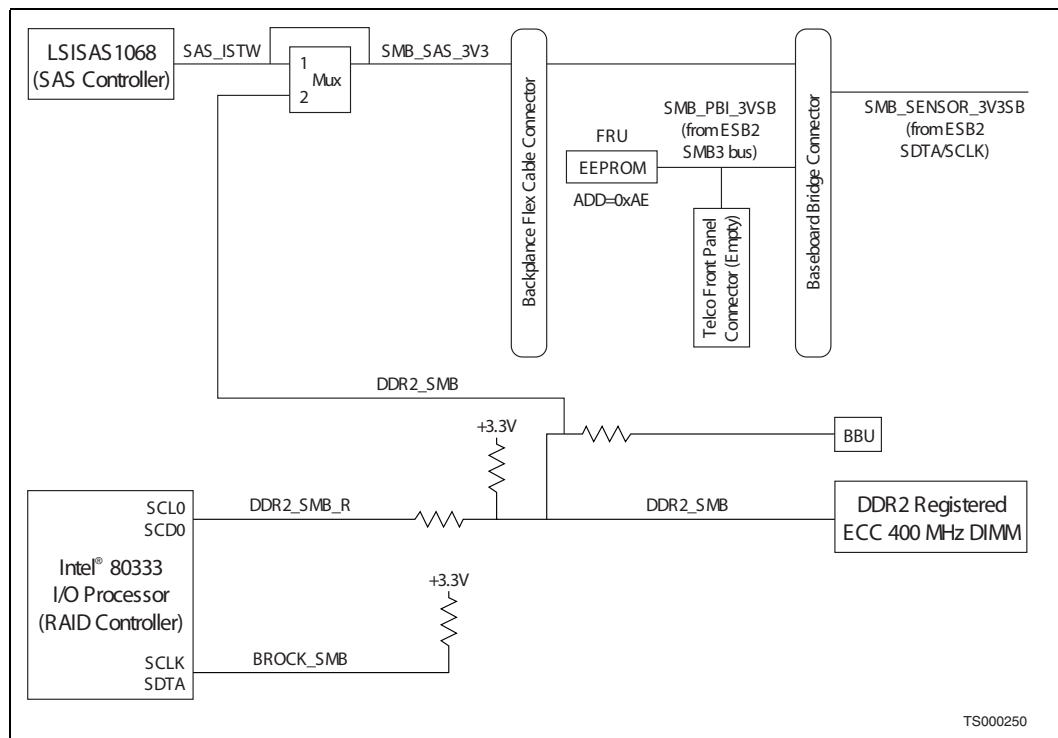
#### 4.5.11 Intel® RAID Activation Key

The Intel® RAID Activation Key is a preprogrammed serial device used to enable hardware RAID.

#### 4.5.12 I<sup>2</sup>C

The 80333 processor's I<sup>2</sup>C bus allows the processor to communicate with the system's BMC and the Intel® RAID Smart Battery. The I<sup>2</sup>C bus going to the system BMC is isolated when power is not provided to the 80333 processor.

Figure 37. I<sup>2</sup>C Circuit



### 4.6 SAS Controller (LSISAS1068)

The LSISAS1068 is a PCI-X SAS controller that provides eight, 3 Gbps SAS links. During normal operation, the LSISAS1068 boots from its Flash. The LSISAS1068 has an assigned SAS ID on the Carrier Grade Server TIGH2U.

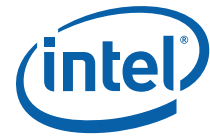
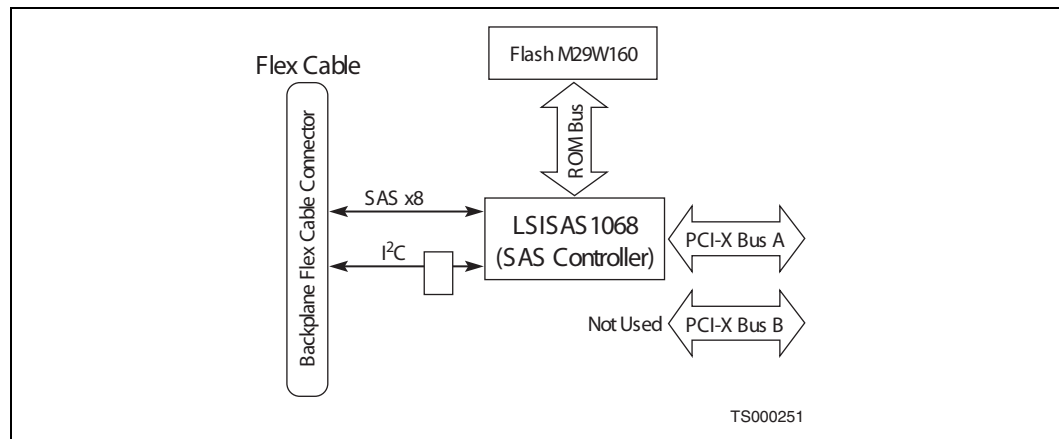


Figure 38. LSISAS1068 Circuit



#### 4.6.1 PCI-X Interface

The LSISAS1068 communicates with the 80333 processor over a 133-MHz, 64-bit PCI-X bus.

#### 4.6.2 SAS Interface

The LSISAS1068 internal SAS interface consists of eight, 3-Gbps links. The SAS interface connects to a system backplane through a flex circuit cable. All supported hardware and software RAID modes are available on the SAS interface.

#### 4.6.3 Flash Memory

A 16 Mbit flash component contains the LSISAS1068's executable code. The LSISAS1068 boots from the flash when the SFP board is operating in SAS mode.

#### 4.6.4 I<sup>2</sup>C

The LSISAS1068's I<sup>2</sup>C bus allows the system's BMC to communicate with the LSISAS1068.

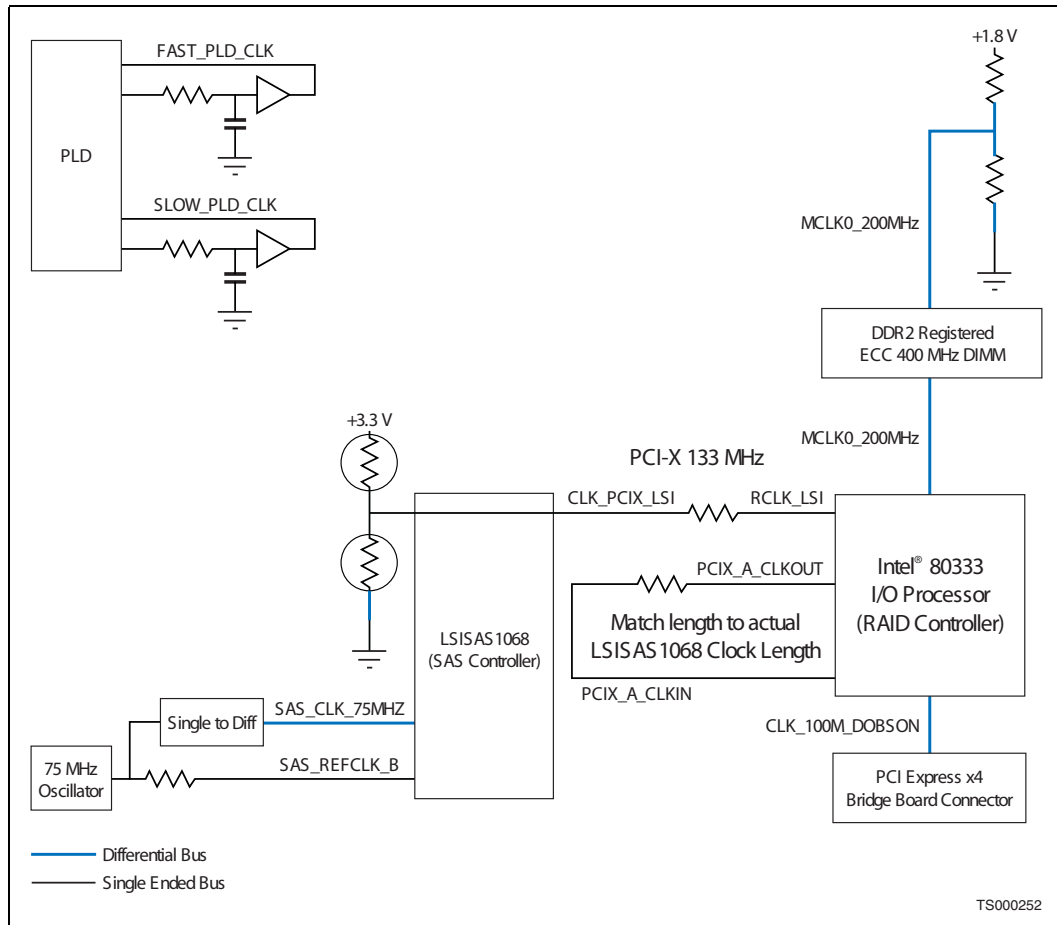
#### 4.6.5 Indicator Buzzer

When the SFP board is in RAID mode, the 80333 processor generates a series of beep codes to indicate failure modes. The 80333 processor indicates the buzzer state via a GPIO. The SFP board's PLD takes the GPIO input and creates a 2 kHz square wave to activate the buzzer.

### 4.7 Clock Generation / Distribution

The SFP board uses several on-board clock sources and a system generated 100-MHz PCI Express clock. Figure 39 shows the clock generation and distribution circuit.

Figure 39. SFP Board Clock Generation and Distribution Circuit



#### 4.7.1 75 MHz Sourced Clock

The LSISAS1068 uses a differential 75 MHz clock, sourced from the 75 MHz oscillator.

#### 4.7.2 133 MHz Sourced Clock

The 80333 processor generates a 133 MHz clock for the PCI-X bus. Skew is controlled by the LSISAS1068 via a feedback circuit.

#### 4.7.3 200 MHz Sourced Clock

The 80333 processor generates a 200 MHz clock for the DDR2 interface.

#### 4.7.4 100 MHz Sourced Clock

The server board provides a 100 MHz clock for the 80333 processor.

#### 4.7.5 PLD Sourced Clock

Uses an external RC circuits and Schmitt\* trigger to generate this clock.



## 4.8 Programmable Logic Device (PLD)

The PLD on the Carrier Grade Server TIGH2U SFP is used for:

- Board power / reset control
- Board interlock control
- Buzzer control
- Intel® RAID Smart Battery control
- Other miscellaneous signals

### 4.8.1 Power-on / Reset

A state machine ensures that the voltage sequencing and reset logic comes up as expected.

### 4.8.2 Buzzer Control

The PLD uses the PLD clock and the AUDIOTRIG signal to generate a 2 kHz signal to drive the buzzer. AUDIOTRIG is generated from GPIO3 on the 80333 processor.

### 4.8.3 Intel® RAID Smart Battery Control

The PLD uses the PLD clock to generate the Intel® RAID Smart Battery control signals, BBE and IBBU\_BBSTROBE. These signals are used to notify the Smart Battery that critical data (dirty) is in the DIMM and that the Smart Battery will have to supply VBAT\_RAID if power fails.

## 4.9 Hardware RAID

The SFP supports hardware RAID levels 0 / 1 / 10 / 5. To use hardware RAID, the following conditions are required:

- The Intel® RAID Activation Key, the RAID mini-DIMM, and the Intel® RAID Smart Battery must be installed.
- The RAID level must be selected in the BIOS.

For information on setting up hardware RAID, see the *Intel® Embedded Server RAID Technology II*, *Intel® Integrated Server RAID*, and *Intel® RAID Controllers SRCAS18E and SRCAS144E Software User's Guide* at <http://support.intel.com/support/motherboards/server/srcsas18e/sb/CS-022358.htm>. This manual is also available on the *Intel® Server Deployment Toolkit* CD.

### 4.9.1 Description

The SFP board supports a RAID On MotherBoard (ROMB) solution via the 80333 processor in conjunction with the LSISAS1068 SCSI controller.

To activate this feature, Intel provides the optional Intel® RAID Activation Key. This key contains a configuration code to unlock specific features to support the LSI Logic MegaRAID\* solution.

Support for a DDR-2 DIMM serves as memory for the IOP and as a disk cache to store write data to the drives. If power to the 80333 processor drops below specifications, the Intel® RAID Smart Battery maintains the contents of the DIMM by keeping the DIMM in self-refresh mode until power is restored. After power is restored, the data is safely written to drives, maintaining the integrity of the disk array.



#### 4.9.2 DDR-2 Support

The SFP board has one 244-pin, DDR2 Mini-DIMM slot to install local memory for the I/O processor. This increases performance by allowing the caching of writes to the disk array. Please check with the current supported memory list. Compatible DIMMS are:

- DDR-2 400 MHz SDRAM only
- Registered DIMMs only
- 72-bit ECC DIMMs only (64-bit data bus width and 8-bit ECC)

#### 4.9.3 Intel® 80333 I/O Processor NVRAM

A 32 Kbyte NVRAM component is connected to the peripheral bus interface (PBI) of the 80333 processor. This NVRAM contains board and disk drive setup configuration data and other system information.

#### 4.9.4 ROMB Battery Backup

The battery backup allows the contents of the DIMM to be preserved if power drops below specifications. See Section 4.5.9, “Intel® RAID Smart Battery” on page 59 for more information.

### 4.10 Software RAID

The SFP board supports software RAID levels 0 / 1 / 10. To use software RAID the following conditions are required:

- The Intel® RAID Activation Key **must not** be installed. The RAID mini-DIMM and the Intel® RAID Smart Battery, which are required for hardware RAID, do not affect the ability to use software RAID.
- Software RAID must be enabled by setting the “software RAID enabled” option in the BIOS.

The “software RAID enabled” option sets the RAID\_MODE signal necessary to distinguish between straight SAS mode and software RAID mode.

#### 4.10.1 80333 Processor in Software RAID

The 80333 processor serves as a PCI Express\* (PCIe\*) to PCI-X\* bridge supporting transfer rates of up to 3 Gbytes/sec. It is connected to the server board's x4 PCI Express link and includes fully functional RAID support. However, the 80333 processor serves as a bridge only in software RAID mode.

#### 4.10.2 LSISAS1068 in Software RAID

The LSISAS1068 controller resides on PCI-X bus, Channel A of the 80333 processor supporting transfer rates of up to 3 Gbps. The LSISAS1068 controller includes an Address Translation Unit (ATU) supporting transactions between PCI address space and 80333 processor address space. Address translation for the ATU is controlled through programmable registers accessible from both the PCI interface and the 80333 processor. The LSISAS1068 controller includes its own Flash ROM to support SAS only software RAID. Software RAID levels supported include 0 / 1 / 10.





## 4.11 Debug Features

### 4.11.1 UART

The SFP board provides a 4-pin UART connector at location J3B1 to assist in the start up and debug of the Intel® 80333 I/O processor firmware code. This connector provides connections to the GPIO0\_RXD and GPIO1\_TXD pins on the 80333 processor.

## 4.12 Power Good Circuit

“Power Good” are positive logic signals reflecting the status of various power rails.

### 4.12.1 Power Good Outputs

“Power Good” outputs allow the SFP board to identify when to come out of reset. The worst case ranges take into account component tolerances and the range represents the smallest expected range.

Table 27. Power Good Table

Voltage	Signal Name	Voltage Range for Good Voltage
+3.3 V	P3V3_STBY_PWRGD	±10% (2.97 V to 3.63 V)
+1.8 V	P1V8_PWRGOOD	+12% / -11% (1.62 V to 1.98 V)
+1.5 V	P1V5_PWRGOOD	±10% (1.35 V to 1.64 V)
+1.35 V	P1V35_PWRGOOD	+9% / -10% (1.21 V to 1.48 V)
+1.2 V	P1V2_PWRGOOD	+13% / -12% (1.06 V to 1.35 V)

### 4.12.2 Power Good Inputs

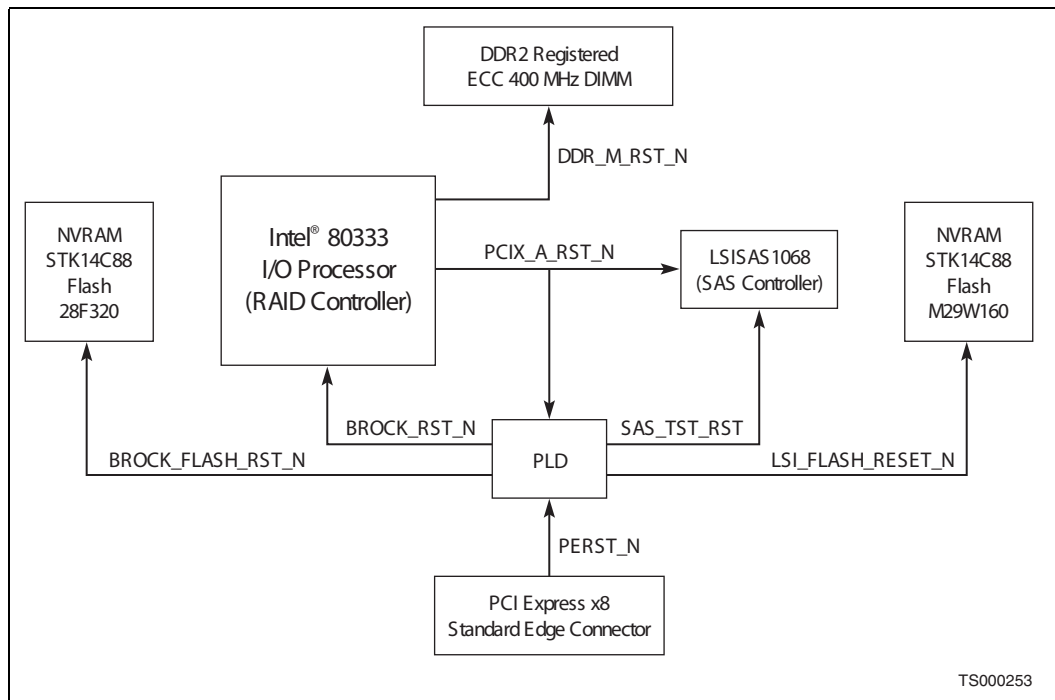
The PCI\_PWRGOOD signal indicates that the +3.3 V power rail supplied by the server board is good.

## 4.13 Reset Control

Board resets are controlled by the Programmable Logic Device (PLD) and are generated from the voltage “Power Good” signals and the PERST\_N PCIe signal.

The Brock\_RST\_N signal must be held off for 1 ms after the 80333 processor power good signal goes active.

Figure 40. Reset Control



## 4.14 Connector Information

### 4.14.1 Baseboard Bridge Connector (J2C1)

The baseboard bridge connector carries signals between the SFP board and the server board. Table 28 gives the pinout for the baseboard bridge connector.

Table 28. Baseboard Bridge Connector Pinout (Sheet 1 of 3)

Pin #	Signal Name	Pin	Signal Name
A1	FAN1_TACH	B1	FAN2_TACH
A2	FAN3_TACH	B2	FAN4_TACH
A3	NC_FAN_TACH5	B3	NC_FAN_TACH6
A4	FAN7_TACH	B4	FAN8_TACH
A5	NC_FAN_TACH9	B5	NC_FAN_TACH10
A6	FAN_CPU2_PWM	B6	GND
A7	GND	B7	FAN_IO_PWM
A8	FAN_CPU1_PWM	B8	LED_FAN4_FAULT
A9	NC_LED_FAN1_FAULT	B9	NC_LED_FAN_FAULT5
A10	NC_LED_FAN2_FAULT	B10	NC_LED_FAN_FAULT6
A11	LED_FAN3_FAULT	B11	GND
A12	FP_TEMP_PWM	B12	NC_V_RED_CONN_FP

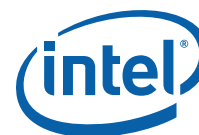


Table 28. Baseboard Bridge Connector Pinout (Sheet 2 of 3)

Pin #	Signal Name	Pin	Signal Name
A13	FP_ID_LED_N	B13	NC_V_GREEN_CONN_FP
A14	R_NC_P3V3STBY	B14	NC_V_BLUE_CONN_FP
A15	FP_PWR_LED_N	B15	GND
A16	R_NC_P3V3	B16	NC_V_VSYNC2_BUF_FP
A17	BB_HDD_ACT_N	B17	NC_V_HSYNC2_BUF_FP
A18	GND	B18	GND
A19	SMB_IPMB_5VSB_CLK	B19	SMB_PBI_3VSB_CLK
A20	SMB_IPMB_5VSB_DAT	B20	SMB_PBI_3VSB_DAT
A21	GND	B21	GND
A22	FP_ID_BTN_N	B22	LED_STATUS_AMBER_N
A23	FP_PWR_BTN_N	B23	LED_NIC2_ACT_N
A24	FP_RST_BTN_N	B24	NC_LED_NIC2_LINK_N
A25	FP_NMI_BTN_N	B25	LED_STATUS_GREEN_N
A26	GND	B26	LED_NIC1_ACT_N
A27	USB0_FP_CONN_DN	B27	NC_LED_NIC1_LINK_N
A28	USB0_FP_CONN_DP	B28	NC_USB2_ESB_OC_N
A29	GND	B29	GND
A30	USB_FP_OC_FLT_N	B30	NC_USB2_ESB_DN
A31	USB_SYSCON_OC_FLT_N	B31	NC_USB2_ESB_DP
A32	GND	B32	GND
A33	USB1_SYSCON_DN	B33	SGPIO_CLOCK
A34	USB1_SYSCON_DP	B34	SGPIO_LOAD
A35	GND	B35	SGPIO_DATAOUT0
A36	FAN_PRSN2_N	B36	SGPIO_DATAOUT1
A37	FAN_PRSN3_N	B37	GND
A38	FAN_PRSN1_N	B38	CLK_100M_DOBSON_P
A39	GND	B39	CLK_100M_DOBSON_N
A40	EXP_NB_OP	B40	GND
A41	EXP_NB_ON	B41	SW_RAID_MODE
A42	GND	B42	GND
A43	IBUTTON_PRESENT	B43	EXP_SB_OP
A44	GND	B44	EXP_SB_ON
A45	EXP_NB_1P	B45	GND
A46	EXP_NB_1N	B46	PCIE_PWRGOOD
A47	GND	B47	GND
A48	FAN_PRSN4_N	B48	EXP_SB_1P
A49	GND	B49	EXP_SB_1N
A50	EXP_NB_2P	B50	GND
A51	EXP_NB_2N	B51	FAN_PRSN5_N
A52	GND	B52	GND



**Table 28. Baseboard Bridge Connector Pinout (Sheet 3 of 3)**

Pin #	Signal Name	Pin	Signal Name
A53	FAN_PRSENT6_N	B53	EXP_SB_2P
A54	GND	B54	EXP_SB_2N
A55	EXP_NB_3P	B55	GND
A56	EXP_NB_3N	B56	PE_WAKE_N
A57	GND	B57	GND
A58	PD_BRIDGE_PRSENT_N	B58	EXP_SB_3P
A59	NC_SMB_SENSOR_3V3SB_DAT_BUF	B59	EXP_SB_3N
A60	NC_SMB_SENSOR_3V3SB_CLK_BUF	B60	GND

#### 4.14.2 Intel® RAID Smart Battery Connector (J8B2)

The Intel® RAID Smart Battery connector carries signals between the SFP board and the Intel® RAID Smart Battery. Table 29 gives the pinout for this connector.

**Table 29. Intel® RAID Smart Battery Connector (J8B2) Pinout**

Pin #	Signal Name	Pin #	Signal Name
1	12V	2	GND
3	NC	4	GND
5	VBAT_RAID	6	GND
7	3.3V	8	GND
9	VBAT_RAID	10	GND
11	RESET_N	12	GND
13	SCK	14	GND
15	SDA	16	PFAIL_N
17	DDR_SEL	18	BBE
19	BBSTROBE	20	STATUS

#### 4.14.3 DDR2 DIMM Connector (J6D1)

Table 30 gives the pinout for the DDR2 DIMM connector.

**Table 30. DDR2 DIMM Connector (J6D1) Pinout (Sheet 1 of 3)**

Pin	Signal Name	Pin	Signal Name	Pin	Signal Name	Pin	Signal Name
1	DDR_VREF	62	DDR_MA<4>	123	GND	184	VBAT_RAID
2	GND	63	VBAT_RAID	124	DDR_DQ<4>	185	DDR_MA<3>
3	DDR_DQ<0>	64	DDR_MA<2>	125	DDR_DQ<5>	186	DDR_MA<1>
4	DDR_DQ<1>	65	VBAT_RAID	126	GND	187	VBAT_RAID
5	GND	66	GND	127	DDR_DM<0>	188	MCLK0_200MHZ_P
6	DDR_DQS_N<0>	67	GND	128	NC_DDR_128	189	MCLK0_200MHZ_N

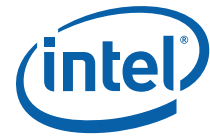


Table 30. DDR2 DIMM Connector (J6D1) Pinout (Sheet 2 of 3)

Pin	Signal Name	Pin	Signal Name	Pin	Signal Name	Pin	Signal Name
7	DDR_DQS_P<0>	68	DDR_PAR_IN	129	GND	190	VBAT_RAID
8	GND	69	VBAT_RAID	130	DDR_DQ<6>	191	DDR_MA<0>
9	DDR_DQ<2>	70	DDR_MA<10>	131	DDR_DQ<7>	192	DDR_BA1
10	DDR_DQ<3>	71	DDR_BA0	132	GND	193	VBAT_RAID
11	GND	72	VBAT_RAID	133	DDR_DQ<12>	194	DDR_RAS_N
12	DDR_DQ<8>	73	DDR_WE_N	134	DDR_DQ<13>	195	VBAT_RAID
13	DDR_DQ<9>	74	VBAT_RAID	135	GND	196	DDR_CSQ_N
14	GND	75	DDR_CAS_N	136	DDR_DM<1>	197	VBAT_RAID
15	DDR_DQS_N<1>	76	VBAT_RAID	137	NC_DDR_137	198	DDR_ODT0
16	DDR_DQS_P<1>	77	NC_DDR_77	138	GND	199	DDR_MA<13>
17	GND	78	NC_DDR_78	139	NC_DDR_139	200	VBAT_RAID
18	DDR_M_RST_N	79	VBAT_RAID	140	NC_DDR_140	201	NC_DDR_201
19	NC_DDR_19	80	NC_DDR_80	141	GND	202	GND
20	GND	81	GND	142	DDR_DQ<14>	203	DDR_DQ<36>
21	DDR_DQ<10>	82	DDR_DQ<32>	143	DDR_DQ<15>	204	DDR_DQ<37>
22	DDR_DQ<11>	83	DDR_DQ<33>	144	GND	205	GND
23	GND	84	GND	145	DDR_DQ<20>	206	DDR_DM<4>
24	DDR_DQ<16>	85	DDR_DQS_N<4>	146	DDR_DQ<21>	207	NC_DDR_207
25	DDR_DQ<17>	86	DDR_DQS_P<4>	147	GND	208	GND
26	GND	87	GND	148	DDR_DM<2>	209	DDR_DQ<38>
27	DDR_DQS_N<2>	88	DDR_DQ<34>	149	NC_DDR_149	210	DDR_DQ<39>
28	DDR_DQS_P<2>	89	DDR_DQ<35>	150	GND	211	GND
29	GND	90	GND	151	DDR_DQ<22>	212	DDR_DQ<44>
30	DDR_DQ<18>	91	DDR_DQ<40>	152	DDR_DQ<23>	213	DDR_DQ<45>
31	DDR_DQ<19>	92	DDR_DQ<41>	153	GND	214	GND
32	GND	93	GND	154	DDR_DQ<28>	215	DDR_DM<5>
33	DDR_DQ<24>	94	DDR_DQS_N<5>	155	DDR_DQ<29>	216	NC_DDR_216
34	DDR_DQ<25>	95	DDR_DQS_P<5>	156	GND	217	GND
35	GND	96	GND	157	DDR_DM<3>	218	DDR_DQ<46>
36	DDR_DQS_N<3>	97	DDR_DQ<42>	158	NC_DDR_158	219	DDR_DQ<47>
37	DDR_DQS_P<3>	98	DDR_DQ<43>	159	GND	220	GND
38	GND	99	GND	160	DDR_DQ<30>	221	DDR_DQ<52>
39	DDR_DQ<26>	100	DDR_DQ<48>	161	DDR_DQ<31>	222	DDR_DQ<53>
40	DDR_DQ<27>	101	DDR_DQ<49>	162	GND	223	GND
41	GND	102	GND	163	DDR_CB<4>	224	NC_DDR_224
42	DDR_CB<0>	103	DIMM1A_SA2	164	DDR_CB<5>	225	NC_DDR_225
43	DDR_CB<1>	104	NC_DDR_104	165	GND	226	GND
44	GND	105	GND	166	DDR_DM<8>	227	DDR_DM<6>
45	DDR_DQS_N<8>	106	DDR_DQS_N<6>	167	NC_DDR_167	228	NC_DDR_228
46	DDR_DQS_P<8>	107	DDR_DQS_P<6>	168	GND	229	GND



Table 30. DDR2 DIMM Connector (J6D1) Pinout (Sheet 3 of 3)

Pin	Signal Name	Pin	Signal Name	Pin	Signal Name	Pin	Signal Name
47	GND	108	GND	169	DDR_CB<6>	230	DDR_DQ<54>
48	DDR_CB<2>	109	DDR_DQ<50>	170	DDR_CB<7>	231	DDR_DQ<55>
49	DDR_CB<3>	110	DDR_DQ<51>	171	GND	232	GND
50	GND	111	GND	172	NC_DDR_172	233	DDR_DQ<60>
51	NC_DDR_51	112	DDR_DQ<56>	173	VBAT_RAID	234	DDR_DQ<61>
52	VBAT_RAID	113	DDR_DQ<57>	174	DDR_CKE1	235	GND
53	DDR_CKE0	114	GND	175	VBAT_RAID	236	DDR_DM<7>
54	VBAT_RAID	115	DDR_DQS_N<7>	176	NC_DDR_176	237	NC_DDR_237
55	NC_DDR_BA2	116	DDR_DQS_P<7>	177	NC_DDR_177	238	GND
56	NC_DDR_ERR_OUT	117	GND	178	VBAT_RAID	239	DDR_DQ<62>
57	VBAT_RAID	118	DDR_DQ<58>	179	DDR_MA<12>	240	DDR_DQ<63>
58	DDR_MA<11>	119	DDR_DQ<59>	180	DDR_MA<9>	241	GND
59	DDR_MA<7>	120	GND	181	VBAT_RAID	242	DDRII_SMBDA
60	VBAT_RAID	121	DIMM1A_SA0	182	DDR_MA<8>	243	DDRII_SMBCL
61	DDR_MA<5>	122	DIMM1A_SA1	183	DDR_MA<6>	244	P3V3

#### 4.14.4 SAS Flex Connector (J2B1)

Table 31 gives the pinout for the SAS flex connector, which connects to the SAS backplane through the flex circuit cable.

Table 31. SAS Flex Connector (J2B1) Pinout

Pin #	Signal Name	Pin #	Signal Name
1	FP_FLEX_PRES_N	41	GND
2	SMB_SAS_3V3_SCL	42	SAS4_RX_N
3	SMB_IPMB_5VSB_CLK	43	SAS3_TX_N
4	SMB_SAS_3V3_SDA	44	GND
5	SMB_IPMB_5VSB_DAT	45	SAS3_TX_P
6	NC_FLEX_CONN_SPARE_12	46	GND
7	NC_FP_FC_7	47	GND
8	SGPIO_CLOCK_R	48	SAS3_RX_N
9	GND	49	GND
10	SGPIO_LOAD_R	50	SAS3_RX_P
11	SAS7_TX_N	51	SAS2_TX_N
12	GND	52	GND
13	SAS7_TX_P	53	SAS2_TX_P
14	GND	54	GND
15	GND	55	GND
16	SAS7_RX_N	56	SAS2_RX_N
17	GND	57	GND

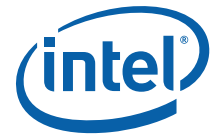


Table 31. SAS Flex Connector (J2B1) Pinout (Continued)

Pin #	Signal Name	Pin #	Signal Name
18	SAS7_RX_P	58	SAS2_RX_P
19	SAS6_TX_P	59	SAS1_TX_N
20	SGPIO_DATAOUT0_R	60	HDD_ACT_N
21	SAS6_TX_N	61	SAS1_TX_P
22	GND	62	GND
23	GND	63	GND
24	SAS6_RX_N	64	SAS1_RX_N
25	GND	65	GND
26	SAS6_RX_P	66	SAS1_RX_P
27	SAS5_TX_N	67	SAS0_TX_P
28	SGPIO_DATAOUT1_R	68	HDD_FLT_N
29	SAS5_TX_P	69	SAS0_TX_N
30	GND	70	GND
31	GND	71	GND
32	SAS5_RX_N	72	SAS0_RX_N
33	GND	73	NC_FP_FC_73
34	SAS5_RX_P	74	SAS0_RX_P
35	SAS4_TX_P	75	NC_DIFF2_P
36	NC_FP_PWR_ENABLE	76	GND
37	SAS4_TX_N	77	NC_DIFF2_N
38	GND	78	NC_FP_FC_78
39	GND	79	GND
40	SAS4_RX_P	80	GND

#### 4.14.5 Serial Cable Header from Server Board (J8B1)

Table 32 gives the pinout for the serial cable header connector.

Table 32. Serial Cable Header (J8B1) Pinout

Pin #	Signal Name
1	EMP_DCD_L
2	EMP_DSR_N
3	EMP_SIN
4	EMP_RTS_N
5	EMP_SOUT
6	EMP_CTS_N
7	EMP_DTR_N
8	NC_EMP_RI_N
9	EMP_INUSE_L



Table 32. Serial Cable Header (J8B1) Pinout (Continued)

Pin #	Signal Name
10	NC_5V_STBY
11	GND
12	NC

#### 4.14.6 Power Connectors

Table 33, Table 34 and Table 34 give the pinouts for power connectors J1D2, J2D2 and J2D1 respectively.

Table 33. SAS Backplane Power Connector (J1D2)

Pin #	Signal Name	Signal Name	Pin #
1	P5V	P5V	7
2	P5V	P5V	8
3	P12V	P3V3	9
4	P12V	GND	10
5	GND	GND	11
6	GND	GND	12

Table 34. PDB Power Connector (J2D2) Pinout

Pin #	Signal Name
1	GND
2	P5V
3	P5V

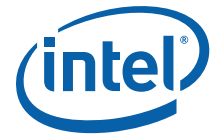
Table 35. PDB Power Connector (J2D1) Pinout

Pin #	Signal Name	Signal Name	Pin #
1	GND	P12V	4
2	GND	P12V	5
3	P5V	P3V3	6

#### 4.14.7 External USB / Serial (J8E1)

Table 36 gives the pinout for the external USB / serial connector on the SFP board. The user-side pinouts for connectors are in Section 3.3, "User-Accessible Interconnects" on page 43.



**Table 36. External USB / Serial Port Connector (J8E1) Pinout**

Pin #	Signal Name
1	GND
2	GND
3	GND
4	GND
5	USB_PWR
6	USB0_FP_CONN_N
7	USB0_FP_CONN_P
8	USB_GND
9	RJ45_EMP_RTS_L
10	RJ45_EMP_DTR_L
11	RJ45_EMP_SOUT
12	GND
13	RJ45_EMP_INUSE_L
14	RJ45_EMP_SIN
15	RJ45_EMP_DSR_DCD_L
16	RJ45_EMP_CTS_L

#### 4.14.8 80333 Processor UART Connector (J3B1)

Table 37 gives the connector pinouts for the UART connector.

**Table 37. 80333 Processor UART Connector (J3B1) Pinout**

Pin #	Signal Name
1	BROCK_UART_TX
2	GND
3	BROCK_UART_RX
4	P3V3

#### 4.14.9 Fan Connectors

Table 38, Table 39, Table 40 and Table 41 give the connector pinouts for the upper fan connector, lower fan connector, CPU1 fan connector and the CPU2 fan connector respectively.

**Table 38. Upper Fan Connector (J1D1) Pinout**

Pin #	Signal Name
1	P12V
2	FAN4_TACH
3	GND



**Table 38. Upper Fan Connector (J1D1) Pinout (Continued)**

Pin #	Signal Name
4	FAN_IO_PWM
5	P12V
6	FAN8_TACH
7	GND
8	FAN_IO_PWM

**Table 39. Lower Fan Connector (J1C1) Pinout**

Pin #	Signal Name
1	P12V
2	FAN3_TACH
3	GND
4	FAN_IO_PWM
5	P12V
6	FAN7_TACH
7	GND
8	FAN_IO_PWM

**Table 40. CPU1 Fan Connector (J7A1) Pinout**

Pin #	Signal Name
1	P12V
2	FAN1_TACH
3	GND
4	FAN_CPU1_PWM

**Table 41. CPU2 Fan Connector (J7A2) Pinout**

Pin #	Signal Name
1	P12V
2	FAN2_TACH
3	GND
4	FAN_CPU2_PWM



#### 4.14.10 Intel® Z-U130 Value Solid State Drive Connector

Table 42 gives the connector pinouts for the Intel® Z-U130 Value Solid State Drive connector.

**Table 42. Intel® Z-U130 Value Solid State Drive Connector Pinout**

Pin #	Signal
1	GND
2	Keyed (no connect)
3	SYSCON_USB_P
4	SYSCON_PWR
5	SYSCON_USB_N
6	GND



## 5.0 SAS Backplane

---

This chapter describes the SAS backplane, which provides support for the SAS hard disk drives and the optical disk drive in the Intel® Carrier Grade Server TIGH2U.

This chapter contains the following sections:

- Overview
- SFP Board Interface
- SAS HDD Interface
- IDE CD ROM / DVD to Server Board Interface
- IDE CD-ROM / DVD-ROM Drive Interface
- Power Connector Interface to Front Panel

### 5.1 Overview

The TIGH2U system contains a SAS backplane that provides support for six 2.5-inch SAS HDD and one slim-line CD-ROM / DVD drive. The backplane interfaces with the SAS front panel (SFP) board, which contains a SFP-2U controller that provides support for up to six standard SAS drives. The backplane board interfaces to the SFP board via a controlled impedance flex cable that contains the six SAS HDD signals, control signals, and system management SMBus signals.

The SAS interface to the HDDs is via the 29-pin SAS connector. Activity and fault LEDs are provided for each of the six HDD positions. A composite fault and activity LED signal for all six drives is sent to the SFP board to drive the front panel drive activity / fault LED.

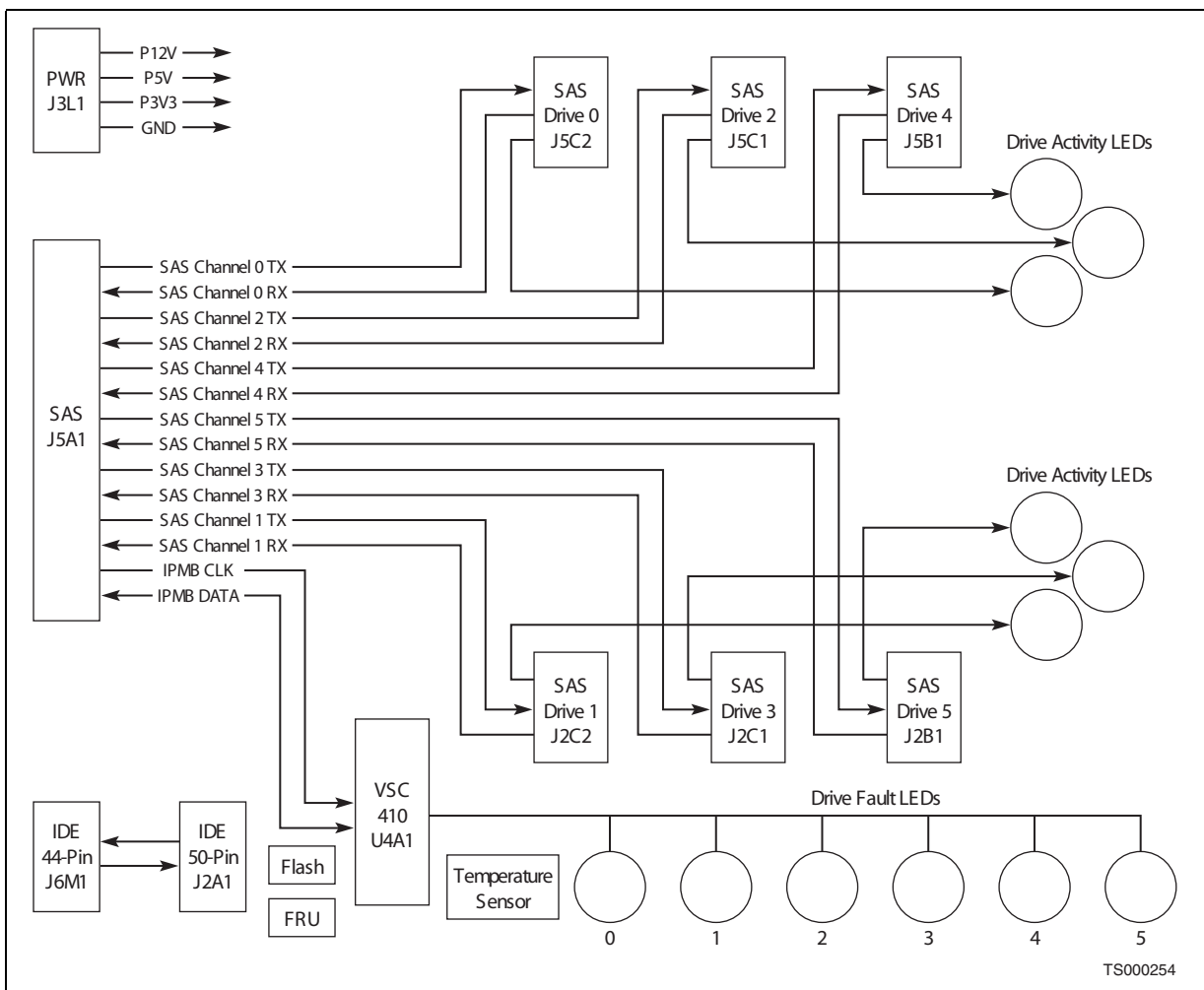
The backplane board also provides the interface between the IDE controller on the Intel® Server Board T5000PAL and the slim-line CD-ROM / DVD drive. The IDE interface to the server board is via a 44-pin ribbon cable.

The DC power to the backplane (12V, 5V, and 3.3V) is provided from the SFP board through a 12-pin (2 x 6) connector.

Figure 41 is a block diagram of the SAS backplane.



Figure 41. SAS Backplane Block Diagram



## 5.2 SFP Board Interface

An 80-pin connector and a flex circuit cable provide the interconnection from the SAS backplane to the SFP board. The flex circuit permits the interconnect using a cable that meets the SI requirements for the SAS signals and meets the mechanical constraints for routing the cable. Table 43 gives the pinout for the 80-pin flex cable connector.

The interconnect supports up to eight SAS channels and the drive management controller interface. For this application, six SAS channels are used.

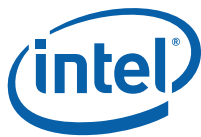


Table 43. 2 x 40 Flex Cable Connector (J5A1) Pinout

Pin #	Signal Name	Pin #	Signal Name
1	FP_FLEX_PRES1	2	SMB_SAS_3V3_SCL
3	IPMB_I2C_SCL	4	SMB_SAS_3V3_SDA
5	IPMB_I2C_SDA	6	NC_FLEX_CONN_6
7	NC_FLEX_CONN_7	8	SGPIO_CLOCK_R
9	GND	10	SGPOI_LOAD_R
11	NC_SAS7_C_TX_N	12	GND
13	NC_SAS7_C_TX_P	14	GND
15	GND	16	NC_SAS7_C_RX_N
17	GND	18	NC_SAS7_C_RX_P
19	NC_SAS6_C_TX_P	20	SGPIO_DATAOUT0_R
21	NC_SAS6_C_TX_N	22	GND
23	GND	24	NC_SAS6_C_RX_N
25	GND	26	NC_SAS6_C_RX_P
27	SAS5_C_TX_N	28	SGPIO_DATAOUT1_R
29	SAS5_C_TX_P	30	GND
31	GND	32	SAS5_C_RX_N
33	GND	34	SAS5_C_RX_P
35	SAS4_C_TX_P	36	NC_FP_PWR_ENABLE
37	SAS4_C_TX_N	38	GND
39	GND	40	SAS4_C_RX_P
41	GND	42	SAS4_C_RX_N
43	SAS3_C_TX_N	44	GND
45	SAS3_C_TX_P	46	GND
47	GND	48	SAS3_C_RX_N
49	GND	50	SAS3_C_RX_P
51	SAS2_C_TX_N	52	GND
53	SAS2_C_TX_P	54	GND
55	GND	56	SAS2_C_RX_N
57	GND	58	SAS2_C_RX_P
59	SAS1_C_TX_N	60	LED_HDD_ACT_R_L
61	SAS1_C_TX_P	62	GND
63	GND	64	SAS1_C_RX_N
65	GND	66	SAS1_C_RX_P
67	SAS0_C_TX_P	68	LED_HDD_FLT_R_L
69	SAS0_C_TX_N	70	GND
71	GND	72	SAS0_C_RX_N
73	NC_FLEX_CONN_73	74	SAS0_C_RX_P
75	NC_DIFF2_P	76	GND



Table 43. 2 x 40 Flex Cable Connector (J5A1) Pinout (Continued)

Pin #	Signal Name	Pin #	Signal Name
77	NC_DIFF2_N	78	NC_FLEX_CONN_78
79	GND	80	FP_FLEX_PRES1
TP1	GND	TP2	GND

### 5.3 SAS HDD Interface

The SAS HDD interface is via the 29-pin SAS connector. Connections are provided for six SAS hard disk drives. Table 44 gives the pinout for the hard drive connectors.

Table 44. Hard Drive Connectors (J5C2, J5C1, J5B1, J2C2, J2C1, J2B1) Pinout

Pin #	Signal Name	Pin #	Signal Name
P1	Not Used	S1	GND
P2	Not Used	S2	SAS#_TX_DP (# = 0..5)
P3	Not Used	S3	SAS#_TX_DN (# = 0..5)
P4	GND	S4	GND
P5	GND	S5	SAS#_RX_DN (# = 0..5)
P6	DRV#_PRSNT_N (# = 0..5)	S6	SAS#_RX_DP (# = 0..5)
P7	P5V Pre-charge	S7	GND
P8	P5V	S8	Not Used
P9	P5V	S9	Not Used
P10	GND	S10	Not Used
P11	LED_SAS#_ACT_L (# = 0..5)	S11	Not Used
P12	GND	S12	Not Used
P13	P12V Pre-charge	S13	Not Used
P14	P12V	S14	Not Used
P15	P12V		
PTH0	GND		
PTY1	GND		

### 5.4 IDE CD ROM / DVD to Server Board Interface

The IDE interface to the server board is via a standard 44-pin IDE connector. Signals 41 to 44 are unused in this application. Table 45 gives the pinout for the slim-line IDE optical driver connector.

Table 45. 2 x 22 Slim-Line IDE Optical Drive Connector (J6M1) Pinout

Pin #	Signal Name	Pin #	Signal Name
1	RST_IDE_L	2	GND
3	RIDE_DD <15..0> 7	4	RIDE_DD <15..0> 8
5	RIDE_DD <15..0> 6	6	RIDE_DD <15..0> 9



**Table 45. 2 x 22 Slim-Line IDE Optical Drive Connector (J6M1) Pinout (Continued)**

Pin #	Signal Name	Pin #	Signal Name
7	RIDE_DD <15..0> 5	8	RIDE_DD <15..0> 10
9	RIDE_DD <15..0> 4	10	RIDE_DD <15..0> 11
11	RIDE_DD <15..0> 3	12	RIDE_DD <15..0> 12
13	RIDE_DD <15..0> 2	14	RIDE_DD <15..0> 13
15	RIDE_DD <15..0> 1	16	RIDE_DD <15..0> 14
17	RIDE_DD <15..0> 0	18	RIDE_DD <15..0> 15
19	GND	20	NC
21	RIDE_DDREQ	22	GND
23	RIDE_DIOW_N	24	GND
25	RIDE_DIOR_N	26	GND
27	RIDE_DIORDY	28	IDE_CSEL
29	RIDE_DDACK_N	30	GND
31	IRQ_IDE	32	RIDE_P32
33	RIDE_DA1	34	IDE_PRI_CBLSNS
35	RIDE_DA0	36	RIDE_DA2
37	RIDE_DCS1_N	38	RIDE_DCS3_N
39	LED_IDE_L	40	GND
41	NC_44P_IDE_P41	42	NC_44P_IDE_P42
43	NC_44P_IDE_P43	44	NC_44P_IDE_P44

## 5.5 IDE CD-ROM / DVD-ROM Drive Interface

The IDE interface to the CD-ROM / DVD drive is via a standard 50-pin connector used on slim-line CD-ROM / DVD drives in laptop computers. Table 46 gives the pinout of the standard 50-pin IDE interface connector for the CD-ROM / DVD drive.

**Table 46. 50-pin Connector to Slim-Line Optical Device (J2A1) Pinout**

Pin #	Signal Name	Pin #	Signal Name
1	NC_50P_IDE_B1	2	NC_50P_IDE_A1
3	GND	4	NC_50P_IDE_A2
5	RIDE_DD<8>	6	RST_IDE_N
7	RIDE_DD<9>	8	RIDE_DD<7>
9	RIDE_DD<10>	10	RIDE_DD<6>
11	RIDE_DD<11>	12	RIDE_DD<5>
13	RIDE_DD<12>	14	RIDE_DD<4>
15	RIDE_DD<13>	16	RIDE_DD<3>
17	RIDE_DD<14>	18	RIDE_DD<2>
19	RIDE_DD<15>	20	RIDE_DD<1>
21	RIDE_DDREQ	22	RIDE_DD<0>
23	RIDE_DIOR_N	24	GND




**Table 46. 50-pin Connector to Slim-Line Optical Device (J2A1) Pinout (Continued)**

Pin #	Signal Name	Pin #	Signal Name
25	GND	26	RIDE_DIOW_N
27	RIDE_DDACK_N	28	RIDE_DIORDY
29	RIDE_P32	30	IRQ_IDE
31	IDE_PRI_CBLSNS	32	RIDE_DA1
33	RIDE_DA2	34	RIDE_DA0
35	RIDE_DCS3_N	36	RIDE_DCS1_N
37	P5V	38	LED_IDE_N
39	P5V	40	P5V
41	P5V	42	P5V
43	GND	44	GND
45	GND	46	GND
47	GND	48	IDE_CSEL_S
49	NC_50P_IDE B25	50	NC_50P_IDE_A25
MP1	GND	MP2	GND

## 5.6 Power Connector Interface to Front Panel

The backplane receives DC power through the SFP Board via a 2 × 6 Molex Micro Fit\* connector. Table 47 give the pinout of the DC power connector.

**Table 47. 12-pin Power Connector to Front Panel Board (J3L1) Pinout**

Pin #	Signal Name	Pin #	Signal Name
1	P5V	7	P5V
2	P5V	8	P5V
3	P12V	9	P3V3
4	P12V	10	GND
5	GND	11	GND
6	GND	12	GND

## 6.0 TAM Board

---

This chapter describes the Telco Alarm Manager (TAM) board, which provides the front panel switches and LEDs and system alarm relays in the Intel® Carrier Grade Server TIGH2U.

This chapter contains the following sections:

- Features
- Overview
- Connector Information

### 6.1 Features

The TAM board provides the following features:

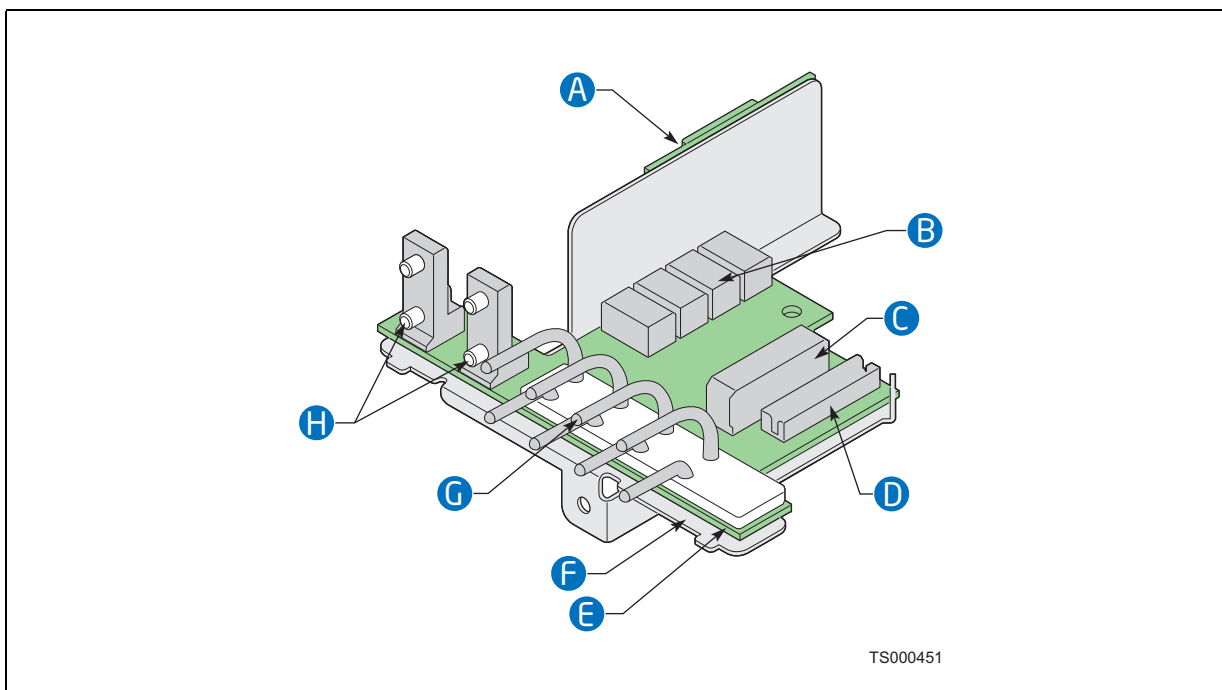
- four switches to control power-on, reset, NMI, and the system ID LED
- one system ID LED that can be controlled remotely or by the system ID switch
- two system activity LEDs that indicate power-on and NIC activity
- one hard drive activity / fault LED that indicates activity / fault status for drives 0 to 5
- four system fault LEDs that indicate critical, major, minor, and power system fault status
- four system fault relays for external critical, major, minor, and power fault indicators
- one connector used to interface with the SFP board
- one connector used to route the contacts of the four system fault relays to a connector on the back of the chassis.

### 6.2 Overview

The TAM board provides the means of mounting and electrically connecting switches and indicators for system operation and status. These features are accessible and visible from the front of the chassis. The TAM board also provides an alarms function with fault relays, providing access via a cable to the back of the system to the fault relay contacts. A ribbon cable connects the TAM board to the SFP board.

Figure 42 shows the TAM board on its mounting bracket. In the figure, the Intel® Z-U130 Value Solid State Drive board is also shown for reference.

Figure 42. TAM Board on Mounting Bracket



Item	Description	Item	Description
A	Intel®Value Solid State Drive	E	TAM Board
B	Alarm Relays	F	TAM Board Bracket
C	Alarms Connector	G	Indicator Lightpipes
D	SFP Board Interface Connector	H	Front Panel Switches (Power, Reset, NMI, ID)

### 6.2.1 Front Panel Switches

The T1GH2U front panel has a power switch, a reset switch, an NMI switch, and a system ID switch. These are physically located on the TAM board. The functions of these switches are described in Table 48.

Table 48. Front Panel Switches

Switch	Function
Power Switch	An ACPI-compliant momentary contact switch that toggles system power on / off
Reset Switch	A momentary switch that resets the system when in the power-on state
NMI Switch	A momentary switch that instructs the processor to copy system memory to hard disk
System ID Switch	A momentary switch that instructs the processor to toggle the state of the system ID LED



## 6.2.2 Front Panel LEDs

The front panel includes LED indicators provided by the TAM board. Details are in Table 49.

**Table 49. Front Panel LEDs**

LED Function	LED Color	Peak Wavelength (nm)	Typical Luminous Intensity (mcd)	Minimum Luminous Intensity (mcd)
ID	White	N/A	8.9	4.5
NIC	Green	560	12	6
ON	Green	560	12	6
DRIVE ACTIVITY / FAULT	Green / amber	568 / 610	20 / 20	7 / 7
CRITICAL alarm	Amber (default) or red	588	15	4
MAJOR alarm	Amber (default) or red	588	15	4
MINOR alarm	Amber	588	10	2.6
POWER alarm	Amber	588	10	2.6

### 6.2.2.1 System Status LEDs

The functions of the status LEDs provided by the TAM board are described in Table 50.

**Table 50. System Status LEDs**

Switch	Function
Power	The green Power LED indicates that system power is on when it is illuminated continuously. When it is blinking green, it indicates that the system is in ACPI sleep mode.
NIC	The green NIC Activity LED indicates network link presence and activity on either NIC0 or NIC1.
System ID	The white System ID LED identifies a particular system. The LED can be toggled remotely or with the System ID switch.
Drive Activity	The green / amber Hard Drive Activity / Fault LED displays activity or fault status for all of the six disk drives populated in the six hot-swap hard drive bays.



### 6.2.2.2 System Fault LEDs

The functions of the system fault LEDs provided by the TAM board are described in Table 51.

**Table 51. System Fault LEDs**

Switch	Function
Critical	The critical alarm LED can be either amber (default) or red (set with an FRUSDR update). This LED is illuminated via the BMC private I <sup>2</sup> C bus, and may only be turned off via BMC private I <sup>2</sup> C control. When continuously lit, it indicates the presence of a "critical system fault". A critical system fault is a system-detected error or event that has a fatal impact to the system. In this case, the system cannot continue to operate. An example is the loss of a large section of memory, or other corruption, that renders the system not operational. The TAM board critical alarm relay (see Section 6.2.3) is engaged.
Major	The major alarm LED can be either amber (default) or red (set with an FRUSDR update). This LED is illuminated via the BMC private I <sup>2</sup> C bus, and may be turned off via BMC private I <sup>2</sup> C control or alarm connector reset. When continuously lit, it indicates the presence of a "major system fault". A major system fault is a system-detected error or event that has discernable impact to system operation. In this case, the system can continue to operate, but in a "degraded" fashion (reduced performance or loss of non-fatal feature reduction). An example is the loss of one of two mirrored disks. The TAM board major alarm relay (see Section 6.2.3) is engaged.
Minor	The minor alarm LED is amber, is illuminated via the BMC private I <sup>2</sup> C bus, and may be turned off via BMC private I <sup>2</sup> C control or alarm connector reset. When continuously lit, it indicates the presence of a "minor system fault". A minor system fault is a system-detected error or event that has little impact to system operation. An example is a correctable ECC error. The front panel minor alarm relay (see Section 6.2.3) is engaged.
Power	The power alarm LED is amber, is illuminated via BMC private I <sup>2</sup> C bus or the SYS_FLT_LED_L signal, and may only be turned off via BMC private I <sup>2</sup> C control. When continuously lit, it indicates the presence of a "power system fault". The TAM board power alarm relay (see Section 6.2.3) is engaged.

### 6.2.3 System Fault Relays

The TAM board contains four relays for power, critical, major and minor alarms. The relays are controlled by the SMBus. Section 6.3.2, "Alarms Connector" on page 86 describes the relay outputs.

## 6.3 Connector Information

The TAM board contains two connectors to interface with the system:

- SFP Interface Connector
- Alarms Connector

### 6.3.1 SFP Interface Connector

The SFP interface connector enables the interconnection of the TAM board and the SFP board using the TAM board signal cable (see Section 3.2.4). Table 52 shows the pinout for the 2 x 12 SFP connector on the TAM board.

**Table 52. SFP Interface Connector Pinout**

Pin	Signal
1	SMB_SENSOR_3V3SB_CLK_BUF
2	FP_PWR_BTN_N
3	SMB_SENSOR_3V3SB_DAT_BUF
4	FP_RST_BTN_N



Table 52. SFP Interface Connector Pinout (Continued)

5	N/C
6	FP_ID_BTN_N
7	FP_NIC_ACT_LED_N
8	FP_NMI_BTN_N
9	FP_PWR_LED_ON_N
10	N/C
11	N/C
12	HDD_ACT_LED
13	N/C
14	HDD_FLT_LED
15	FP_ID_LED_N
16	N/C
17	5V
18	5V STBY
19	5V
20	5V STBY
21	GND
22	GND
23	GND
24	GND

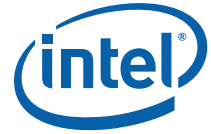
### 6.3.2 Alarms Connector

The alarms connector enables interconnection between the TAM board and the alarms port interface on the back of the system. The alarms port interface is a standard DB15 connector. Each alarm (major, minor, critical and power) is the output of an Single Pole, Double Throw (SPDT) relay contact. A common contact with normally-open and normally-closed connections is included. The power alarm has common and normally-open contacts only. Reset circuit contacts are provided for the major and minor alarms.

Table 53 shows the pinout for the 2 x 12 alarms connector on the TAM board.

Table 53. Alarms Connector Pinout

Pin	Signal
1	Minor reset positive
3	Minor reset negative
5	Major reset positive
7	Major reset negative
9	Critical alarm normally open
11	Critical alarm normally closed
13	Critical alarm common
15	Minor alarm normally open
2	Minor alarm normally closed
4	Minor alarm common
6	Major alarm normally open

**Table 53. Alarms Connector Pinout (Continued)**

8	Major alarm normally closed
10	Major alarm common
12	Power alarm normally open
14	Power alarm common

The telco alarms signal cable (see Section 3.2.5), which routes the alarm relay contacts to the back of the TIGH2U system, connects to the alarms connector on the TAM board.



## 7.0 Intel® Z-U130 Value Solid State Drive

---

This chapter describes the basic functions and interface requirements of the Intel® Z-U130 Value Solid State Drive. The information contained in this chapter is organized into the following sections:

- Functional Description
- SFP Board Connector
- Architecture
- Installation

### 7.1 Functional Description

Key features of the Intel® Z-U130 Value Solid State Drive are:

- capacity of 1, 2, or 4 Gbyte
- sequential read performance of 28 Mbyte per second
- sequential write performance of 20 Mbyte per second
- supports USB 2.0 / 1.1 specification

The Intel® Z-U130 Value Solid State Drive attaches to an interposer board and is used with the SAS Front Panel (SFP) board to provide local memory storage for various options including, but not limited to, operating system, system information, diagnostic partitions, and configuration data.

Figure 43 shows the Intel® Z-U130 Value Solid State Drive board as it attaches to the interposer board and Figure 44 gives the dimensions of the Solid State Drive.





Figure 43. Intel® Z-U130 Value Solid State Drive Connection to Interposer Board

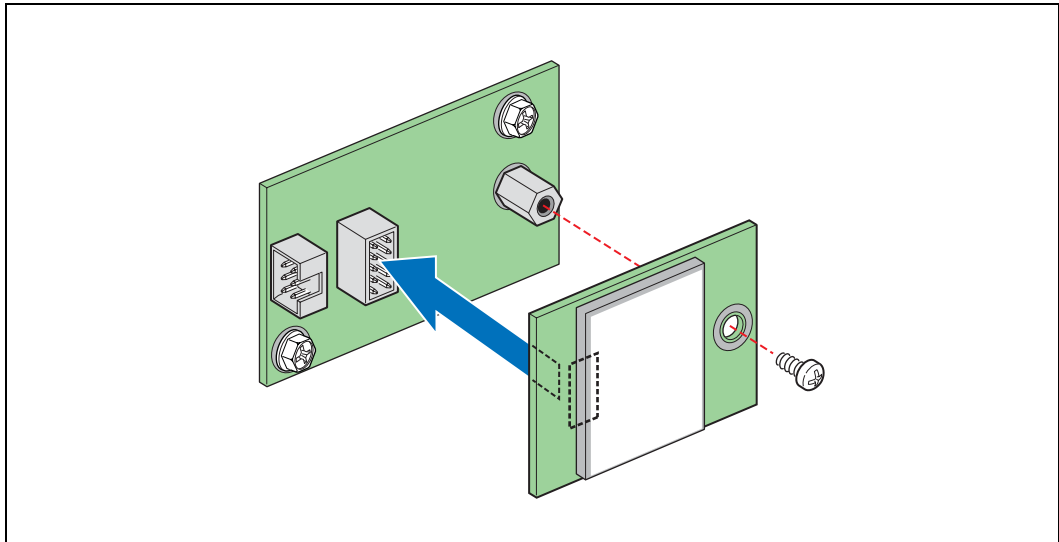
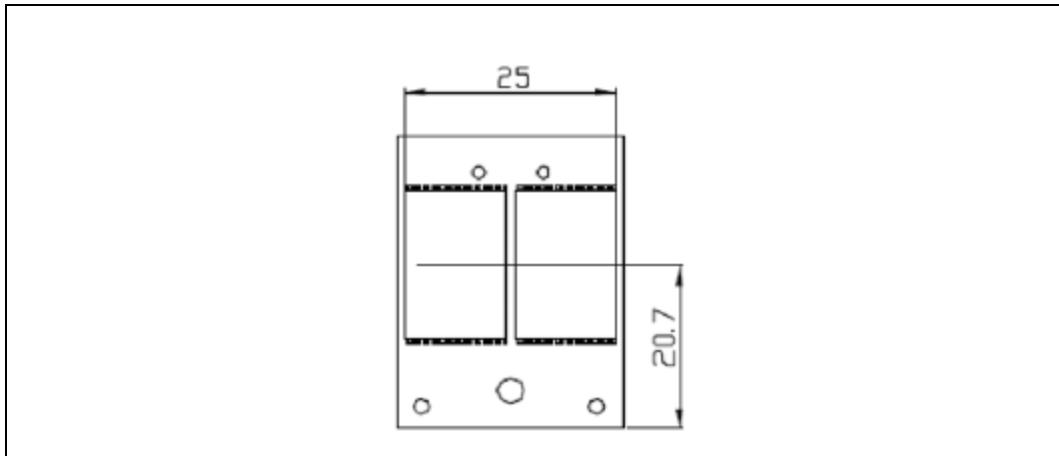


Figure 44. Intel® Z-U130 Value Solid State Drive Dimensions



Because this is a removable media device, it can be moved with current data from one machine to another for cloning system configurations and system options, or for other operations. The connection for the Intel® Z-U130 Value Solid State Drive is made by a USB channel provided by the SFP board.



## 7.2 SFP Board Connector

Table 54 lists the pinout of the 2 x 3 connector that interfaces to the SFP board.

**Table 54. 2 x 3 Connector Pinout**

Pin	Blind Mate Signal	Pin	Blind Mate Signal
1	GND	2	N/C (Pin Pulled)
3	USB_Data_Plus (D+)	4	VBUS (+5V)
5	USB_Data_Minus (D-)	6	GND

## 7.3 Architecture

The solid state drive combines Intel® NAND Flash memory and a USB controller to deliver a solution for embedded and thin client markets. The system is based on a single level cell (SLC) flash technology. Each capacity option (1, 2, or 4 Gbyte) contain two NAND flash devices. The high-speed USB 2.0 controller includes 4 symbol error correction capability and wear-leveling algorithms for enhanced NAND management. The controller is backward-compatible to the USB 1.1 specification and complies with USB Mass Storage Class Specification v1.0.

## 7.4 Installation

The Intel® Z-U130 Value Solid State Drive is installed onto an interposer board. The interposer board attaches to the TAM board.





## 8.0 PCI Riser Cards

---

This chapter describes the design and external interface of the PCI riser cards used in the Intel® Carrier Grade Server TIGH2U.

This chapter contains the following sections:

- PCI-X and PCIe Add-in Card Options
- PCI Express Riser Card Mechanical Specifications

The system contains a riser assembly that includes two different riser cards that connect directly to the Intel® Server Board T5000PAL. One riser card facilitates the installation of full-height PCI-X\* and PCI Express\* (PCIe\*) add-in cards. The other riser card facilitates low-profile PCIe add-in cards.

Each riser card is attached to the PCI riser assembly using two keyhole features and two 6/32-inch screws. Two blue flexible handles on the riser assembly facilitate the separation of the riser cards from their corresponding server board connectors when removing the riser assembly from the chassis. See Section 2.3.2, “PCI/PCI Express Subsystem” on page 24 for more information.

Figure 45 shows the full-height PCI-X / PCIe riser card and Figure 46 shows the low-profile PCIe riser card.



Figure 45. Full-Height PCI-X / PCIe Riser Card

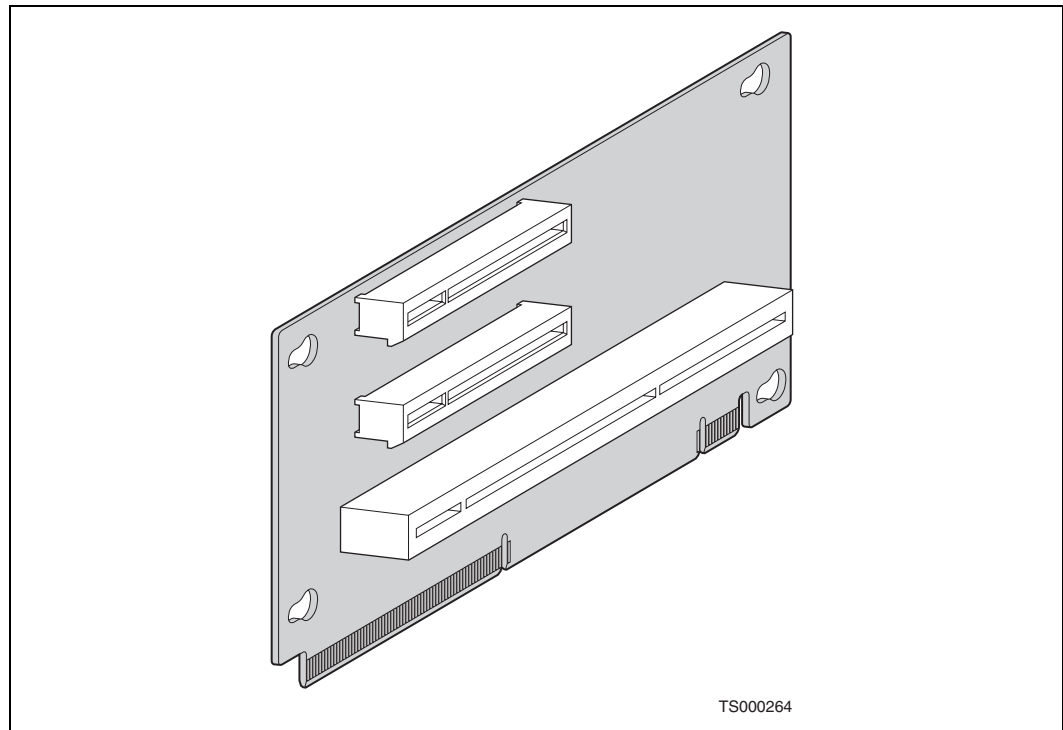
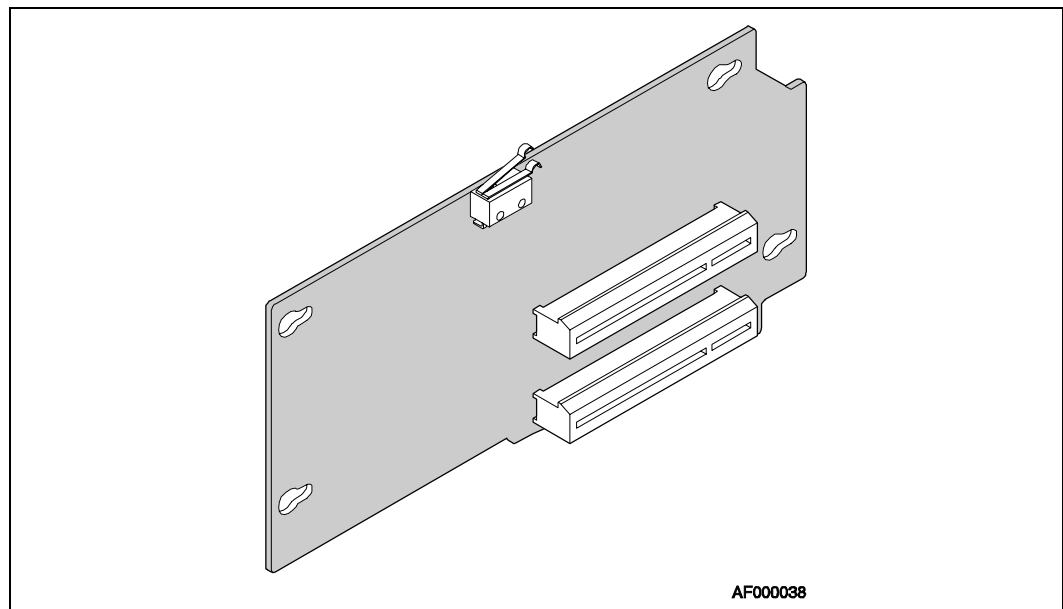


Figure 46. Low-Profile PCIe Riser Card





## 8.1 PCI-X and PCIe Add-in Card Options

The Intel® Server Board T5000PAL has two riser slots that support riser cards for 2U system configurations. The two slots are physically different and provide different capabilities.

The full-height riser slot (J4F1) implements Intel® Adaptive Slot technology and uses a 280-pin connector that meets both PCI-X and PCIe technology specifications. The full-height riser card supports the following interfaces: PCI-X, PCIe x4 and PCIe x8. Table 55 shows the supported throughput and the number of add-in cards installed for each possible configuration.

**Table 55. Full-Height Riser Card Configurations and Throughput**

Configuration	Bottom Slot	Middle Slot	Top Slot
1 add-in card	PCI-X †	–	–
	–	x8 or x4 PCIe	–
	–	–	x4 PCIe
2 add-in cards	PCI-X †	x8 or x4 PCIe	–
	PCI-X †	–	x4 PCIe
	–	x4 PCIe	x4 PCIe
3 add-in cards	PCI-X †	x4 PCIe	x4 PCIe
<b>Note:</b> † Up to 133 MHz bus speed			

The low-profile riser slot (J5B1) uses a 98-pin connector. It can support up to two low-profile PCIe add-in cards. The low-profile riser only supports x4 PCIe interfaces. Table 56 shows the supported throughput and the number of add-in cards installed for each possible configuration.

**Table 56. Low-Profile Riser Card Configurations and Throughput**

Configuration	Lower Slot	Upper Slot
1 add-in card	x4 PCIe †	
		x4 PCIe †
2 add-in cards	x4 PCIe †	x4 PCIe †
† The riser card's PCIe slots can physically accommodate boards with x1, x4 or x8 connectors, but the link interface to each slot is only x4 maximum.		

**Note:** There are no population rules for installing a single low-profile add-in card in the 2U low-profile riser card; a single add-in card can be installed in either PCIe slot.

## 8.2 PCI Express Riser Card Mechanical Specifications

Figure 47 shows the mechanical specification of the low-profile passive PCI Express riser card and Figure 48 shows the mechanical specification of the full-height PCI Express riser card.



Figure 47. Low-Profile Passive PCIe Riser Card Mechanical Specification

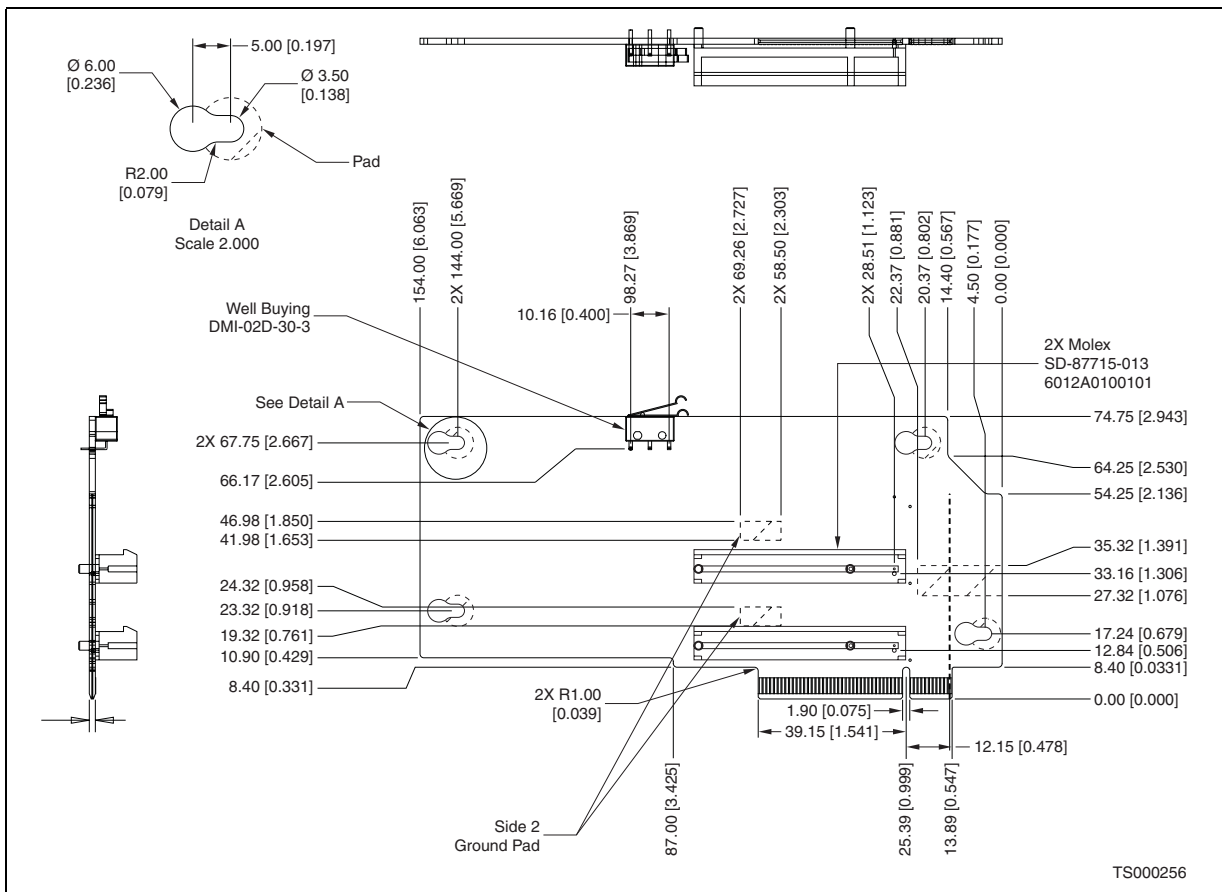
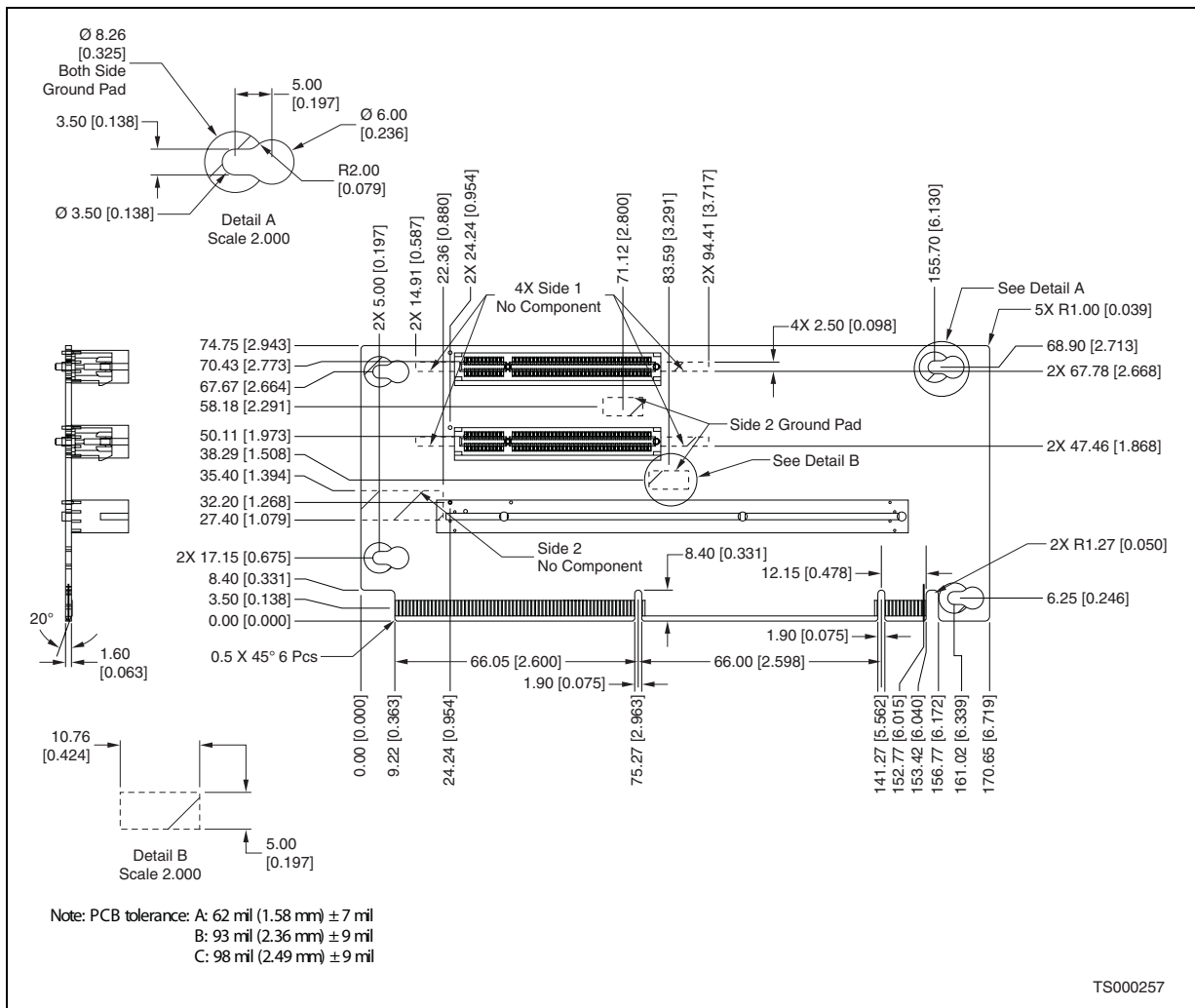


Figure 48. Full-Height PCI-X / PCIe Riser Card Mechanical Specification









## 9.0 Power Subsystem

---

This chapter defines the features and functionality of the switching power subsystem of the Intel® Carrier Grade Server T1GH2U. The power subsystem can use either AC-input or DC-input power supply modules. The subsystem comprises one or two PSUs and a Power Distribution Board (PDB). If two PSUs are used, the system can operate in redundant mode.

The information contained in this chapter is organized into the following sections:

- Features
- Power Supply Cage
- Power Supply Module Characteristics
- AC-input Power Supply Module
- DC-input Power Supply Module

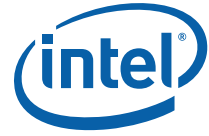
### 9.1 Features

Power subsystem features include:

- Support for AC-input and DC-input power supply modules
- 600 W power module output capability in full AC or DC input voltage range
- 580 W subsystem total output capability in full input voltage range
- Power good indication LEDs
- Predictive failure warning
- Internal cooling fans with multi-speed capability
- Remote sense of 3.3 V, 5 V, and 12 V DC outputs (on the PDB)
- Brown-out protection and recovery
- Built-in load sharing capability
- Built-in overloading protection capability
- Onboard field replaceable unit (FRU) information
- I<sup>2</sup>C interface for server management functions
- Integral handle for insertion / extraction

### 9.2 Power Supply Cage

The power supply cage of the Carrier Grade Server T1GH2U support one 600 W SSI Thin Power Supply (TPS) module for a 1+0 non-redundant configuration or two TPS modules for a 1+1 redundant configuration that supports hot swap.

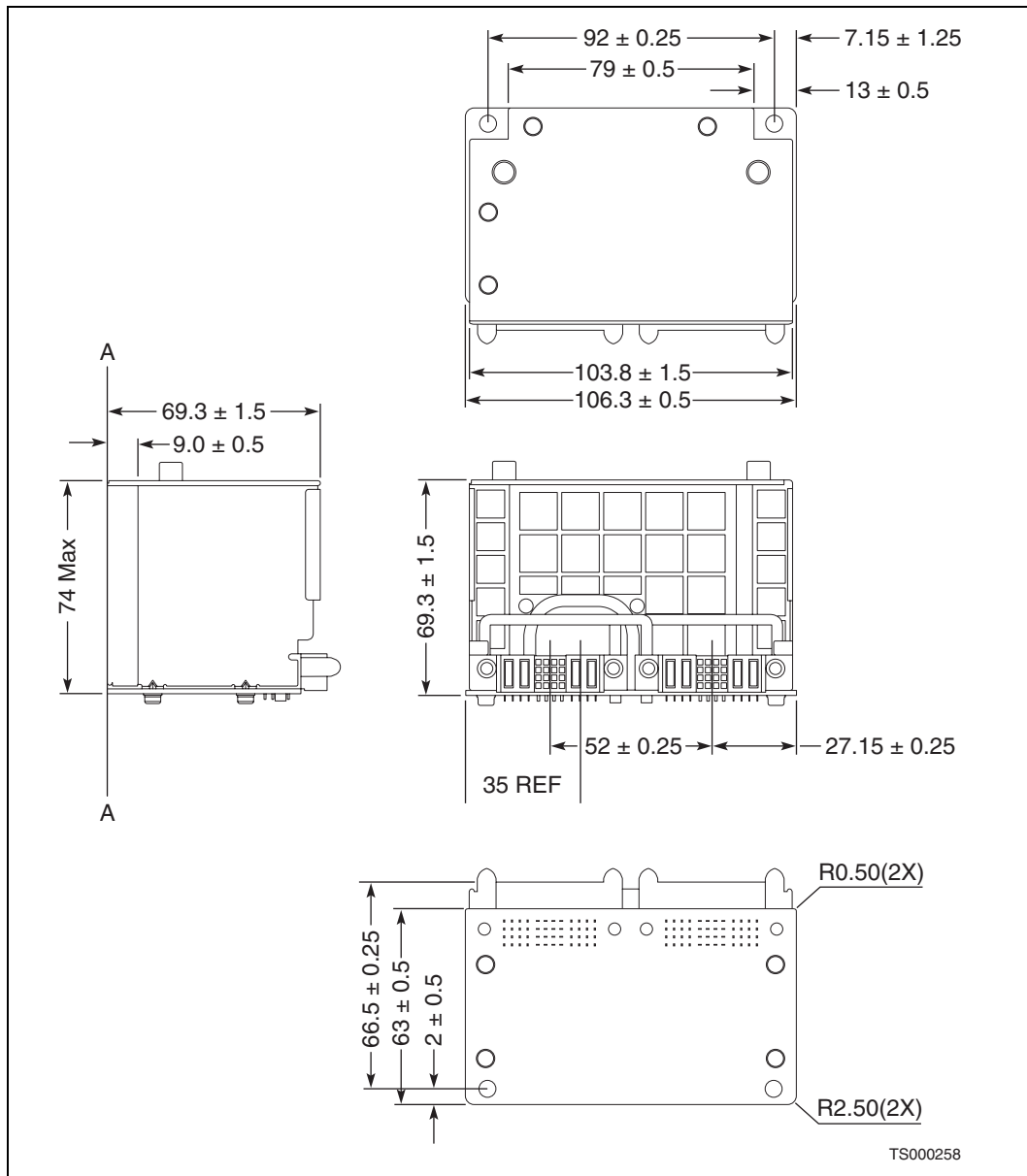


The power cage provides mating connectors for two power supply modules and a power distribution board (PDB) that contains DC-to-DC converters for the 5V and 3.3V supply rails and connectors to distribute the rails to the Intel® Server Board T5000PAL and SAS front panel (SFP) board.

### 9.2.1 Power Supply Cage Mechanical Specification

The Carrier Grade Server TIGH2U supports up to two 600 W PSUs in a 1+1 configuration or a 1+0 configuration. A mechanical drawing of the power supply cage is shown in Figure 49.

Figure 49. Power Supply Cage Mechanical Specification



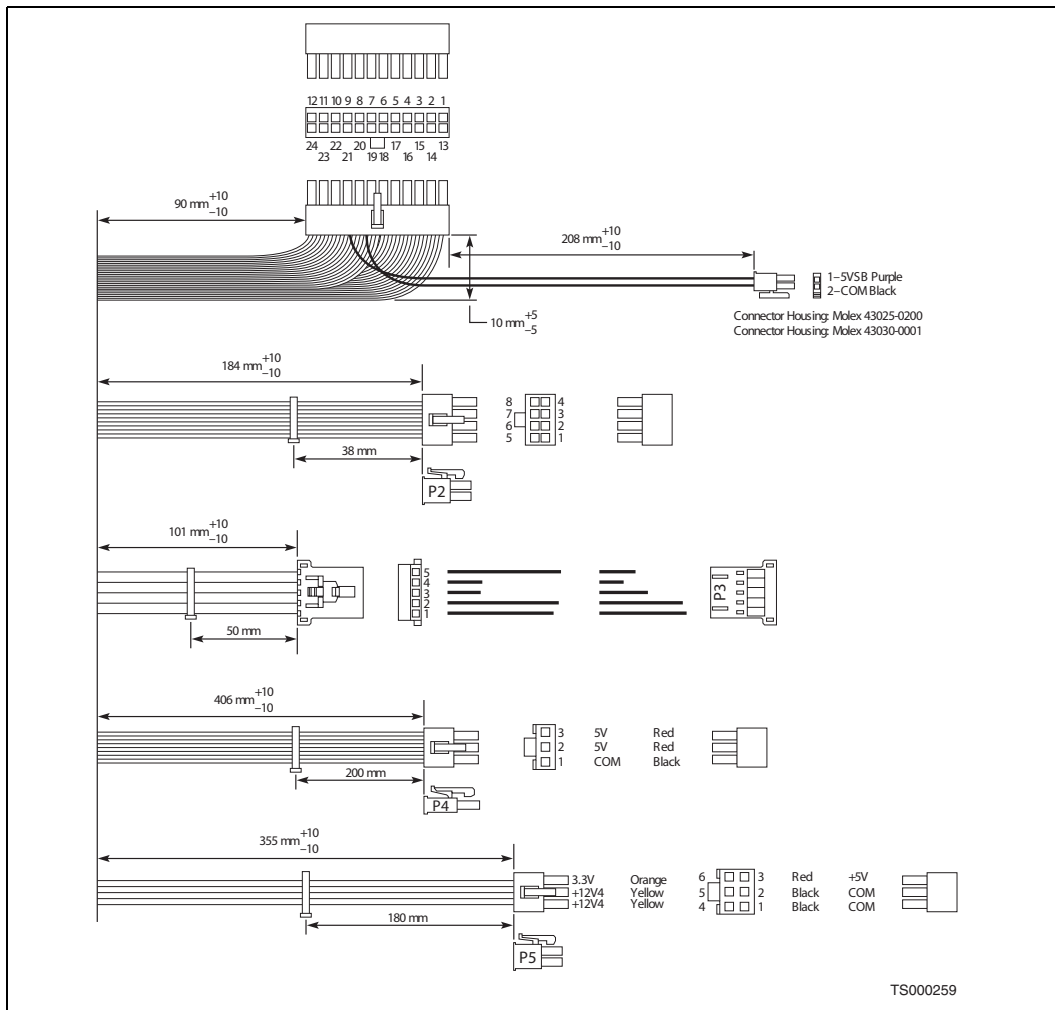
### 9.2.2 Power Supply Cage System Interface

The Power Distribution Board (PDB) in the power supply cage connects to the server board and the front panel board via captive wire harnesses. All wiring uses listed or recognized component appliance wiring material (AVLV2), VW-1 flame rating, rated 105° C minimum, 300 VDC minimum. Table 57 gives the length of each wiring harness and Figure 50 gives wiring harness details.

Table 57. Power Supply Cage Wiring Harness Cable Lengths

From	To Connector	No of Pins	Length (mm)	Description
Backplane cover exit hole	P1	2 x 12	90, turn 90°	Server Board Power Connector
	P2	2 x 4	184	Processor Power Connector
	P3	1 x 5	101	Power Signal Connector
	P4	1 x 3	406	SFP Power Connector
	P5	2 x 3	355	SFP Power Connector

Figure 50. Power Supply Cage Output Wire Harness Detail





### 9.2.3 P1 Server Board Power Connector

A 24-pin Molex\* 39-01-2245 (or equivalent) connector and harness from the power supply cage provides the server board (J3K3) with the required voltages and interface signals. Table 58 shows the pinout.

**Table 58. 24-pin Server Board Power Connector Pinout**

Pin	Signal	Wire Color (18 AWG)	Pin	Signal	Wire Color (18 AWG)
1	+3.3 VDC	Orange	13	+3.3 VDC	Orange
2	+3.3 VDC	Orange	14	-12 VDC	Blue
3†	COM (GND)	Black	15	COM	Black
	COM	Black (24 AWG)			
4††	+5 VDC	Red	16	PS_ON#	Green
	5V RS	Red (24 AWG)			
5	COM	Black	17	COM	
6	+5 VDC	Red	18	COM	Black
7†	COM	Black	19	COM	Black
	COM	Black (24 AWG)			
8	PWR OK	Gray	20	Reserved	NC
9†††	5VSB	Purple	21	+5 VDC	Red
	5VSB	Purple (24 AWG)			
10	+12 V3	Yellow / blue stripe	22	+5 VDC	Red
11	+12 V3	Yellow / blue stripe	23	+5 VDC	Red
12	+3.3 VDC	Orange	24	COM	Black
† COM wire double crimped †† 5V Remote Sense wire double crimped ††† 5VSB wire double crimped					

### 9.2.4 P2 Processor Power Connector

An 8-pin Molex 39-01-2085 (or equivalent) connector and harness from the power supply cage provides the server board (J3K4) with the required +12 V power for the processors. Table 59 shows the pinout.

**Table 59. P2 Processor Power Connector Pinout**

Pin	Signal	Wire Color (18 AWG)	Pin	Signal	Wire Color (18 AWG)
1	COM	Black	5	+12 V1	Yellow / black stripe
2	COM	Black	6	+12 V1	Yellow / black stripe
3	COM	Black	7	+12 V2	Yellow / white stripe
4	COM	Black	8	+12 V2	Yellow / white stripe



### 9.2.5 P3 Power Signal Cable

A 5-wire cable with a Molex 50-57-9705 (or equivalent) female housing connector directs power management signals to the server board (J3K1). Table 60 shows the pinout.

Table 60. P3 Power Signal Cable Pinout

Pin	Signal	24 AWG Wire Color	Description
1	SMBus Clock (SCL)	White / green stripe	Serial Clock
2	SMBus Data (SDL)	White / yellow stripe	Serial Data; information from the power supply
3	SMBAlert#	White	Indicates power supply is operating beyond its limits and has failed or may fail soon
4	COM	Black	Return remote sense
5	3.3RS	Orange / white stripe	3.3V sense
<b>Note:</b> If the server signal connector is unplugged, the PS / PDB-combo does not shut down or go into an OVP condition.			

### 9.2.6 P4 SFP Board Power Connector

A 3-wire cable with a Molex Mini-Fit Jr.\* PN# 39-01-4031 (or equivalent) connector provides power to the SAS Front Panel (SFP) board. Table 61 shows the pinout.

Table 61. P4 SFP Board Power Connector Pinout

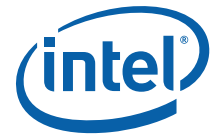
Pin	Signal	22 AWG Wire Color
1	COM	Black
2	5 V	Red
3	5 V	Red

### 9.2.7 P5 SFP Board Power Connector

A 6-wire cable with a Molex Mini-Fit Jr. PN# 39-01-2065 connector provides additional power to the SFP board.

Table 62. P5 SFP Board Power Connector Pinout

Pin	Signal	18 AWG Wire Color
1	COM	Black
2	COM	Black
3	5 V	Red
4	12 V4	Yellow
5	12 V4	Yellow
6	3.3 V	Orange



## 9.2.8 Output Current Requirements

Table 63 gives the +12V output power requirements from the Power Distribution Board (PDB) with one or two 600W PSUs plugged into the input of the PDB.

**Table 63. +12V Outputs Load Ratings**

	+12 V1	+12 V2	+12 V3	+12 V4
<b>Maximum Load</b>	16 A	16 A	16 A	16 A
<b>Minimum Static / Dynamic Load</b>	0 A	0 A	0 A	0 A
<b>Peak Load (12 seconds)</b>	18 A	18 A	18 A	18 A
<b>Maximum Output Power</b>	12 V x 16 A = 192 W	12 V x 16 A = 192 W	12 V x 16 A = 192 W	12 V x 16 A = 192 W
<b>Notes:</b>				
1. The combined total power limit for all outputs is 580 W maximum.				
2. +12 V1 / 2 / 3 / 4 combined output limit = 46.2 A / 63 A peak maximum.				

Table 64 gives the power and current ratings of the two DC/DC converters located on the PDB, each powered from the +12V rail. The converters meet both static and dynamic voltage regulation requirements for the minimum and maximum loading conditions.

**Table 64. DC/DC Converters Load Ratings**

	+12 VDC Input DC/DC Converters	
	+3.3 V Converter	+5 V Converter
<b>Maximum Load</b>	20 A	26 A
<b>Minimum Static / Dynamic Load</b>	0.5 A	0.5 A
<b>Maximum Output Power</b>	20 A x 3.3 V = 66 W	26 A x 5 V = 130 W
<b>Note:</b> 3.3 V / 5 V combined power limit: 150 W maximum.		

## 9.2.9 Hot Swapping Power Modules

Hot swapping a power supply module is the process of extracting and inserting a PSU from an operating system. The Carrier Grade Server TIGH2U power subsystem can support hot swapping of power supply modules in a 1+1 configuration.

## 9.2.10 Intelligent Cage Functions

The PSU and Power Distribution Board (PDB) combination provides a monitoring interface to the system over a server management bus. The device is compatible with both SMBus 2.0 "high power" and I<sup>2</sup>C Vdd-based power and drive. This bus may operate inside the PSU and PDB at 5 V (powered from stand-by voltage), however, looking from the system server management into the PSU and PDB combination, it is compatible with the 3.3 V bus. A bi-directional I<sup>2</sup>C voltage translator is employed on the PDB. The SMBus pull-ups are located on the server board.

The PDB's I<sup>2</sup>C bus has a dual function:

- provide PSU and PDB monitoring features
- convey the stored FRU data in the PSU and PDB EEPROM

### 9.2.11 FRU Data

The power supply cage contains a 2 Kbyte EEPROM device that contains FRU data for the cage according to the IPMI specification. Each separate output is given a different number for identification purposes.

## 9.3 Power Supply Module Characteristics

The Carrier Grade Server T1GH2U can be configured with either AC-input or DC-input power supply modules, which have the same physical dimensions and share many of the same characteristics and specifications. The common characteristics are described in this section and then details about differences are described.

### 9.3.1 Power Supply Module to Cage Interconnect

The power supply provides a pluggable terminal block, which mates to a connector located at the PDB. This is a blind mating type connector that connects the power supply's output voltages and signals.

The power supply must be provided with a reliable protective earth ground, and all secondary circuits must be connected to that protective earth ground. Resistance of the ground returns to chassis must not exceed 1.0 mΩ. This path may be used to carry DC current.

Figure 51 shows the outline of the mating connector. Table 65 provides pinout information.

Figure 51. Power Supply Module Output Connector

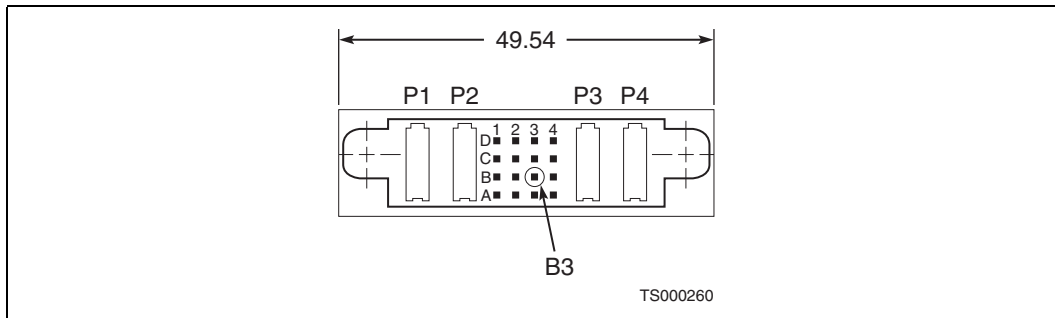


Table 65. Power Supply Module Output Connector Pinout

Signal Pins				
Position	1	2	3	4
D	+12 VRDS	-12 V	+5 VSB	+5 VCC
C	PWOK	RS RTN	+5 VSB	A0
B	+12 VLS	RESERVE	PS KILL†	A1
A	PS ON#	SDA	SLC	PS ALERT#

† Signal pin B3 is shortened.





Table 65. Power Supply Module Output Connector Pinout (Continued)

Power Blades				
P1	P2	P3	P4	
+12V	+12 V	RTN	RTN	
† Signal pin B3 is shortened.				

### 9.3.2 Output Current Ratings

Each PSU provides three outputs: +12 V, +5 V standby, and -12 V voltages. The main +5 V and 3.3 V rails are generated by DC-to-DC converters on the PDB. The combined maximum output power of all outputs is 600W (680 W peak). Each output has a maximum and minimum current rating as shown in Table 66.

Table 66. PSU Load Ratings

	+12V	+5V Standby	-12V
<b>Maximum Load</b>	49.0 A	2.0 A	0.5 A
<b>Minimum Dynamic Load</b>	2.5 A	0.1 A	0.0 A
<b>Minimum Static Load</b>	0.5 A	0.1 A	0.0 A
<b>Peak Load</b> (12 seconds minimum)	56.0 A	2.5 A	N/A
<b>Maximum Output Power</b> (continuous), see note 1	49 A x 12 = 588 W max.	2A x 5V = 10 W max.	0.5 A x 12 V = 6 W max.
<b>Peak Output Power</b> (for 12 seconds minimum), see note 2	56 A x 12 V = 672 W peak	2.5 A x 5 V = 12.5 W peak	N/A
<b>Notes:</b>			
1. At maximum load, the output voltages are allowed to sag to -4%. For the 12 V output, this results in 11.52 V, so the actual maximum power will then be 11.52 V x 49 A = 564.5 W. For the 5V standby output, the maximum load voltage can sag to 4.80V so the actual maximum power is 4.80 V x 2 A = 9.6 W. The total maximum continuous power is therefore 564.5 + 9.6 = 571.4 W.			
2. At peak load, the output voltages are allowed to sag to -4%. For the 12 V output, this results in 11.52 V, so the actual maximum power will then be 11.52 V x 56 A = 645 W. For the 5 V standby output, the maximum load voltage can sag to 4.80 V so the actual maximum power is 4.80 V x 2.5 A = 12 W. The total maximum continuous power is therefore 645 + 12 = 657 W.			

### 9.3.3 Air Flow

Each power supply module incorporates one 40 mm fan for self-cooling, which also contributes to overall system cooling. The PSU fan provides no less than 10 CFM airflow through the power supply when installed in the system and operating at maximum fan speed. The cooling air enters the power module from the PDB side (pre-heated air from the system). The fan's variable speed is based on output load and ambient temperature. Under standby mode, the fans run at minimum RPM.

### 9.3.4 Thermal Protection

Each PSU incorporates thermal protection that causes a shutdown if airflow through the PSU is insufficient. Thermal protection activates shutdown before the temperature of any PSU component passes the maximum rated temperature. This shutdown takes place before over-temperature induced damage to the PSU can occur.

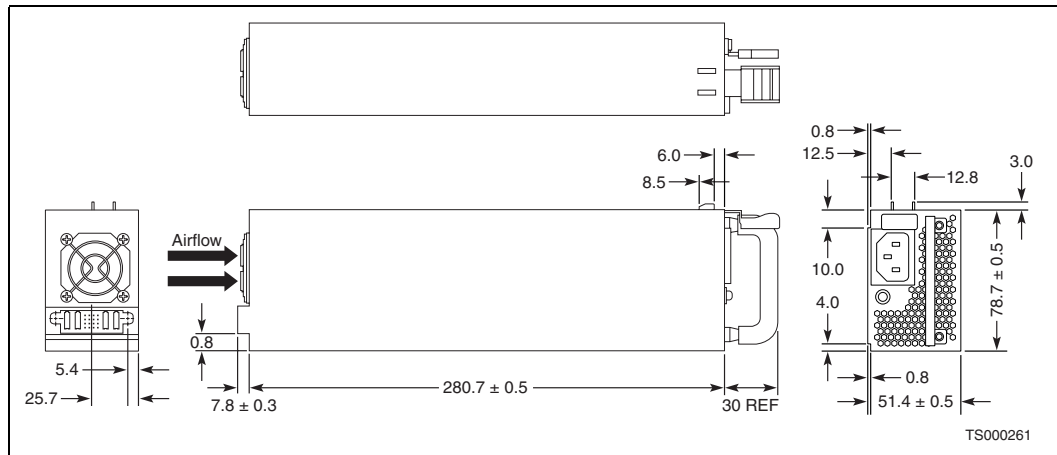
## 9.4 AC-input Power Supply Module

The AC-input power system supports one 600 W SSI TPS (Thin Power Supply) module for a non-redundant configuration, or two in a 1+1 redundant configuration.

### 9.4.1 AC-Input PSU Mechanical Specification

Figure 52 shows the mechanical specification of the AC-input power supply module. Measurements are in millimeters.

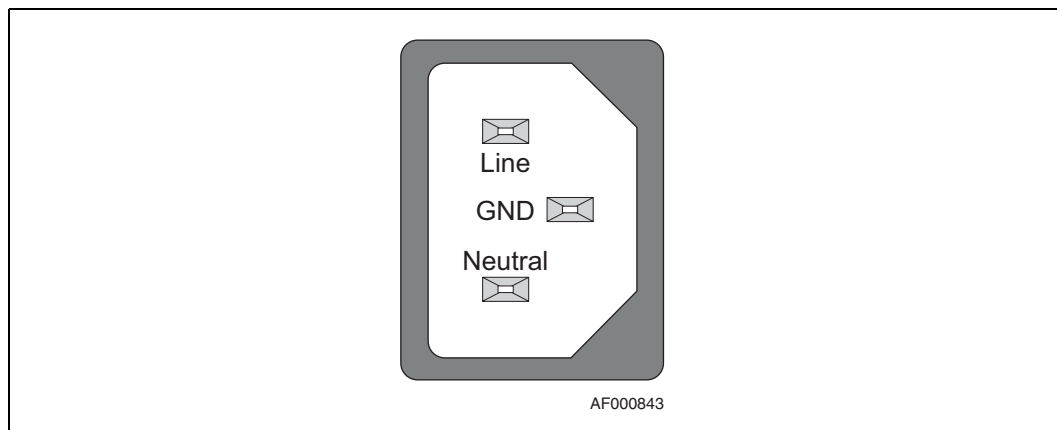
Figure 52. AC-Input Power Supply Module Mechanical Specification



### 9.4.2 AC-Input PSU Power Input Connector

Figure 53 shows the power input connector on the AC-input PSU.

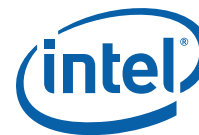
Figure 53. AC-Input Power Supply Module Input Connector



### 9.4.3 AC-Input PSU LED Indicators

The AC-input PSU provides one external, bi-color LED to indicate the status of the power supply.

When AC is applied to the PSU and standby voltages are available, the LED blinks green.



The LED is solid green when all the power outputs are available.

The LED is solid amber when the PSU has failed or has shut down due to over-current or over-temperature.

Table 67 summarizes the AC-Input PSU LED indications.

**Table 67. AC-Input PSU LED Indicators**

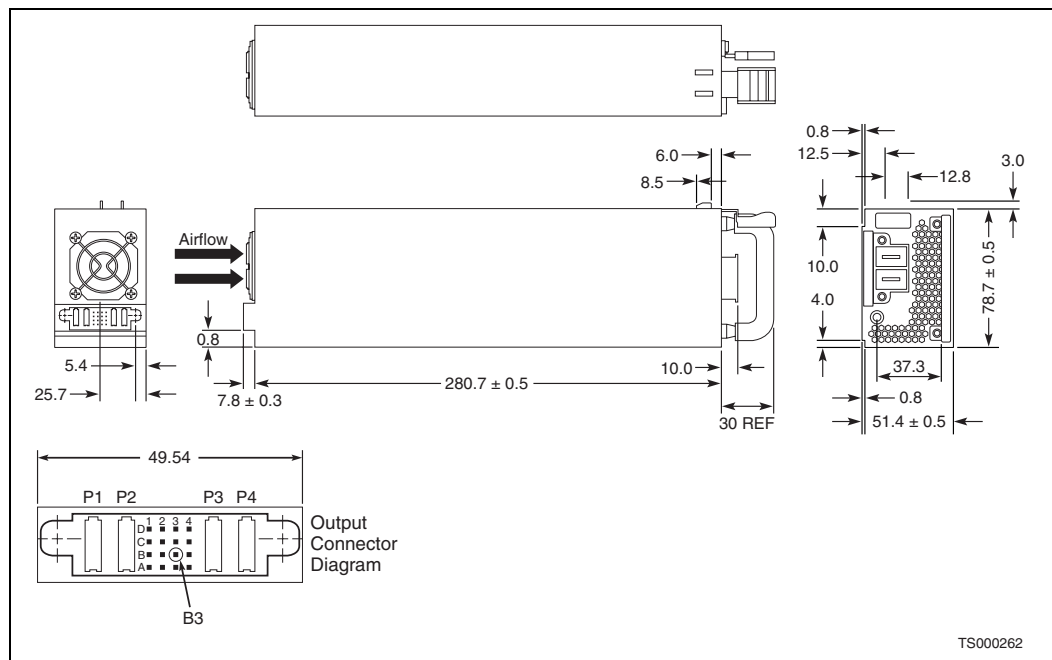
Bi-color LED Indication	Power Supply Condition
OFF	No AC input power to any power supply
Amber	No AC power input to this PSU only (for 1 + 1 configuration) or Power supply <b>critical event</b> causing a shutdown, such as: failure, fuse blown (1 + 1 only), OCP (12 V), OVP (12 V), fan failed
1 Hz Blinking Amber	Power supply <b>warning event</b> , but the power supply <b>continues to operate</b> , such as: high temp, high power / high current, slow fan
1 Hz Blinking Green	AC input present, only 5 Vsb on (volts standby on, PS switched off)
Green	Output on and OK

## 9.5 DC-input Power Supply Module

### 9.5.1 DC-Input PSU Mechanical Specification

Figure 54 shows the mechanical specification of the DC-input power supply module. Measurements are in millimeters.

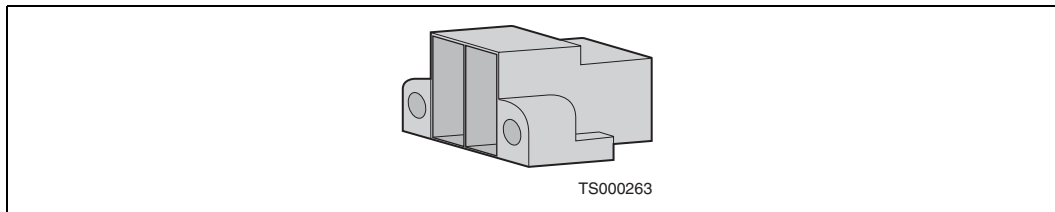
**Figure 54. DC-Input Power Supply Module Mechanical Specification**



### 9.5.2 DC-Input PSU Power Input Connector

Figure 55 shows the power input connector on the DC-input PSU.

Figure 55. DC-Input Power Supply Module Input Connector



### 9.5.3 DC-Input PSU LED Indicators

The DC-input PSU provides one external, bi-color LED to indicate the status of the power supply.

When DC is applied to the PSU and standby voltages are available, the LED blinks green.

The LED is solid green when all the power outputs are available.

The LED is solid amber when the PSU has failed or shut down due to over-current, or over-temperature.

Table 68 summarizes the DC-Input PSU LED indications.

Table 68. DC-Input PSU LED Indicators

Bi-color LED Indication	Power Supply Condition
OFF	No DC input power to any power supply
Amber	No DC power input to this PSU only (for 1 + 1 configuration) or Power supply <b>critical event</b> causing a shutdown, such as: failure, fuse blown (1 + 1 only), OCP (12 V), OVP (12 V), fan failed
1 Hz Blinking Amber	Power supply <b>warning event</b> , where the power supply <b>continues to operate</b> , such as: high temp, high power / high current, slow fan
1 Hz Blinking Green	DC input present, only 5 Vsb on (volts standby on, PS switched off)
Green	Output on and OK





## 10.0 Regulatory Specifications

---

The Intel® Carrier Grade Server T1GH2U system meets the specifications and regulations for safety and EMC defined in this chapter.

### 10.1 Safety Compliance

USA / Canada	UL 60950-1, 1 <sup>st</sup> Edition / CSA 22.2
Europe	Low Voltage Directive, 73/23/EEC TUV/GS to EN60950-1, 1 <sup>st</sup> Edition
International	CB Certificate and Report to IEC60950-1, 1 <sup>st</sup> Edition and all international deviations

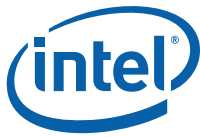
### 10.2 Electromagnetic Compatibility

USA	FCC 47 CFR Parts 2 and 15, Verified Class A Limit
Canada	IC ICES-003 Class A Limit
Europe	EMC Directive, 89/336/EEC EN55022, Class A Limit, Radiated & Conducted Emissions EN55024 Immunity Characteristics for ITE EN61000-4-2 ESD Immunity (level 2 contact discharge, level 3 air discharge) EN61000-4-3 Radiated Immunity (level 2) EN61000-4-4 Electrical Fast Transient (level 2) EN61000-4-5 Surge EN61000-4-6 Conducted RF EN61000-4-8 Power Frequency Magnetic Fields EN61000-4-11 Voltage Fluctuations and Short Interruptions EN61000-3-2 Harmonic Currents EN61000-3-3 Voltage Flicker
Australia/New Zealand	EN55022, Class A Limit
Japan	VCCI Class A ITE (CISPR 22, Class A Limit)
Taiwan	BSMI Approval, CNS 13438, Class A and CNS13436 Safety
Korea	RRL Approval, Class A
China	CCC Approval, Class A (EMC and Safety)
Russia	Gost Approval (EMC and safety)
International	CISPR 22, Class A Limit, CISPR 24 Immunity

### 10.3 CE Mark

The CE marking on this product indicates that it is in compliance with the European Union's EMC Directive 89/336/EEC, and Low Voltage Directive 73/23/EEC.





## Appendix A: Glossary

---

This appendix contains important acronyms and terms used in the preceding chapters.

Term	Definition
A, Amp	Ampere
AC	Alternating current
ATA	Advanced Technology Attachment
AWG	American wire gauge
BIOS	Basic input/output system
BMC	Baseboard management controller
Bridge	Circuitry that connects one computer bus to another
Byte	8-bit quantity
C	Centigrade
CE	Community European
CFM	Cubic feet per minute
CISPR	International Special Committee on Radio Interference
CSA	Canadian Standards Organization
CTS	Clear to send
D2D	DC-to-DC
DC	Direct current
DDR	Dual Data Rate
DIMM	Dual inline memory module
DOSA	Distributed-power Open Standards Alliance
DPC	Direct Platform Control
DRAM	Dynamic random access memory
DSR	Data set ready
DTR	Data terminal ready
ECC	Error checking and correcting
EEPROM	Electrically erasable programmable read-only memory
EMC	Electromagnetic compatibility
EMP	Emergency management port
EN	European Standard (Norme Européenne or Europäische Norm)
ESD	Electrostatic discharge
F	Fahrenheit
FBD	Fully Buffered DRAM
FCC	Federal Communications Commission





Term	Definition
Flash ROM	EEPROM
FRB	Fault resilient booting
FRU	Field replaceable unit
G	Acceleration in gravity units, 1G = 9.80665 m/s <sup>2</sup>
GbE	Gigabit Ethernet
GB, Gbyte	Gigabyte – 1024 Mbytes
GND	Ground (Earth)
GPIO	General purpose input/output
Grms	Root mean square of acceleration in gravity units
HDD	Hard disk drive
HSC	Hot-swap controller
Hz	Hertz – 1 cycle/second
I/O	Input/output
I <sup>2</sup> C	Inter-integrated circuit bus
IBBU	Intel® RAID Smart Battery
ICMB	Intelligent Chassis Management Bus
IDE	Integrated drive electronics
IPMI	Intelligent Platform Management Initiative
ITE	Information technology equipment
Kbyte	Kilobyte – 1024 bytes
kV	Kilovolt – 1,000 volts
LAN	Local area network
LED	Light-emitting diode
mA	Milliampere
Mbyte	Megabyte – 1024 Kbytes
Mbps	Millions of bits per second
mcd	Millicandela
mm	Millimeter
MPS	Multiprocessor specification
mΩ	Milliohm
NIC	Network interface card
nm	Nanometer
NMI	Nonmaskable interrupt
OEM	Original equipment manufacturer
OS	Operating system
OTP	Over-temperature protection
OVP	Over-voltage protection
PCI	Peripheral component interconnect
PCIe	PCI Express peripheral component interconnect
PLD	Programmable Logic Device
PnP	Plug and play



Term	Definition
POST	Power-on Self Test
PSU	Power supply unit
PWM	Pulse width modulation
RAID	Redundant Array of Independent Drives
RPM	Revolutions per minute
RTS	Request to send
SAS	Serial Attached SCSI
SCL	Serial clock
SCSI	Small Computer Systems Interface
SDR	Sensor data records
SDRAM	Synchronous dynamic RAM
SEL	System event log
SFP	SAS Front Panel
SGRAM	Synchronous graphics RAM
SM	Server management
SMBIOS	System management BIOS
SMBus	Subset of I2C bus/protocol (developed by Intel)
SPDT	Single-Pole, Double-Throw
SSI	Server system infrastructure
TUV	Technischer Überwachungs-Verein (A safety testing laboratory with headquarters in Germany)
UART	Universal Asynchronous Receiver/Transmitter
UL	Underwriters Laboratories, Inc.
USB	Universal Serial Bus
V	Volt
VA	Volt-amps (volts multiplied by amps)
Vac	Volts alternating current
VCCI	Voluntary Control Council for Interference
VDC	Volts direct current
VGA	Video graphics array
VRM	Voltage regulator module
VSB	Voltage standby
W	Watt
Ω	Ohm

