



Intel® Server Platforms SR6850HW4 and SR6850HW4/M Power Cord Enabling Specification

Revision 1.2

August 2006

Enterprise Platforms and Services Division - Marketing

Revision History

Date	Revision Number	Modifications
April 2005	1.0	Initial release.
January 2006	1.1	Updated document format, added Russia section, minor corrections to the text.
August 2006	1.2	Minor corrections to the text added SR6850HW4/M

Disclaimers

Information in this document is provided in connection with Intel® products. No license, express or implied, by estoppel or otherwise, to any intellectual property rights is granted by this document. Except as provided in Intel's Terms and Conditions of Sale for such products, Intel assumes no liability whatsoever, and Intel disclaims any express or implied warranty, relating to sale and/or use of Intel products including liability or warranties relating to fitness for a particular purpose, merchantability, or infringement of any patent, copyright or other intellectual property right. Intel products are not intended for use in medical, life saving, or life sustaining applications. Intel may make changes to specifications and product descriptions at any time, without notice.

The Intel® Server Platforms SR6850HW4 and SR6850HW4/M Power Cord Enabling Specification may contain design defects or errors known as errata which may cause the product to deviate from published specifications. Current characterized errata are available on request.

Intel and Xeon are trademarks or registered trademarks of Intel Corporation or its subsidiaries in the United States and other countries.

Copyright © Intel Corporation 2006.

*Other names and brands may be claimed as the property of others.

Table of Contents

1. Overview	1
2. Power Cord Specifications	1
3. 1570 Watt Power Supply Cordsets	1
3.1 How to Purchase	1
3.2 1570 Watt Power Supply Specifications	1
3.3 Cord and Service	2
3.3.1 North American Power Supply Cordsets	2
3.3.2 European Power Supply Cordsets.....	4
3.3.3 Chinese Power Supply Cordsets	5
3.3.4 United Kingdom Power Supply Cordsets.....	6
3.3.5 Russia Power Supply Cordsets	7

List of Tables

Table 1. Interpower* Corporation North American Cordset 250VAC	2
Table 2. Interpower Corporation North American Cordset 125VAC	3
Table 3. Quail Electronics* North American Cordset 250VAC	3
Table 4. Quail Electronics North American Cordset 125VAC	4
Table 5. Interpower Corporation Continental Europe Cordset.....	4
Table 6. Quail Electronics Continental Europe Cordset.....	5
Table 7. Quail Electronics Chinese Cordset	5
Table 8. Interpower Corporation United Kingdom Cordset	6
Table 9. Quail Electronics United Kingdom Cordset.....	6
Table 10. Incoll* Incorporated Russia Cordset	7

< This page intentionally left blank. >

1. Overview

This document is provided to assist Intel's customers with the procurement of power cords for the Intel® Server Platforms SR6850HW4 and SR6850HW4/M.

The following information is available for each power cord by geographical region: a general description of the component and its function, current part numbers and revision levels, and vendor contact information.

2. Power Cord Specifications

The Intel® Server Platform SR6850HW4 does not include power cordsets for the one or two 1570 Watt power supplies. This is due to the unique requirements and the differing AC services in the various regions where the system may be shipped.

The maximum input/output power expectations of the Intel® Server Platforms SR6850HW4 and SR6850HW4/M are as follows:

System power input	77% minimum efficiency at >90 VAC
System power output	3150 W at >180VAC

Cordsets are not interchangeable between the Intel® Server Platforms SR4850HW4 / SR4850HW4/M and Intel® Server Platforms SR6850HW4 / SR6850HW4/M. This is due to the differences in the power supply AC inlet connectors between the platforms. The 1570 Watt power supply has an IEC320 C20 AC input connector (mates with C19 cord plug).

3. 1570 Watt Power Supply Cordsets

3.1 How to Purchase

Please refer to the vendor information below to aid in sourcing a suitable power cordset from suppliers. These selections are assembled cordsets, not raw parts. Check power source outlets in order to determine if the selection is suitable. All selections should be further verified for the safety requirements of each application by a certified safety and regulatory professional.

3.2 1570 Watt Power Supply Specifications

The maximum input/output power expectations of the 1570 Watt power supply are:

Nominal Input Voltage	110/115/240 VAC
Minimal Input Voltage	85 VAC
Maximum Input Voltage	264 VAC
Maximum Input Current	15A at 100VAC (11.25A at 180VAC)
AC Inlet connector	IEC320 C20 (rated for 15A,

250VAC)

3.3 Cord and Service

The following criteria should be used for the wire cord and AC service selection for installation of the Intel® Server Platforms SR6850HW4 and SR6850HW4/M. The selections should be further verified for the safety requirements of each application, by a certified safety and regulatory professional.

- In North America, the cord must be UL Listed/CSA Certified, 14/3, type SJT/SO/STO, with NEMA 5-15P or equivalent attachment plug for 100-127 VAC, or UL Listed/CSA Certified, 16/3, type SJT/SO, with NEMA 6-15 or equivalent attachment plug for 200-240 VAC and IEC 320 C19 plug outlet.
- Outside of North America, the cord must be flexible VDE certified or HAR rated 250V, 3 x 1mm minimum conductor size with IEC 320 C19 outlet, and rated for no less than the product ratings. The AC wall attachment plug shall be a three conductor grounding type, rated at 125% of the total input current rating and must be for the configuration of the specific region or country. The AC wall attachment plug must bear at least an accepted safety agency certification mark for the specific region or country.
- The cord must be no longer than 4.5 meters (14.76 feet).
- Do not attempt to modify or use an AC power cord that is not the exact type required.

3.3.1 North American Power Supply Cordsets

Table 1. Interpower* Corporation North American Cordset 250VAC

Part Number	86226060
Contact Telephone Number	1-800-662-2290
Vendor Website	http://www.interpower.com/
Equipment End	IEC 60320 C19
Supply End	NEMA 6-15
Current Rating	15A
Voltage Rating	250VAC
Length	2.5 meters

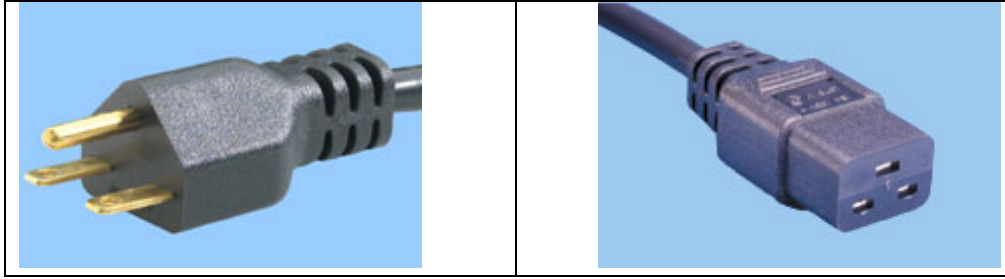

Table 2. Interpower Corporation North American Cordset 125VAC

Part Number	86226020
Contact Telephone Number	1-800-662-2290
Vendor Website	http://www.interpower.com/
Equipment End	IEC 60320 C19
Supply End	NEMA 5-20
Current Rating	20A
Voltage Rating	250VAC
Length	2.5 meters

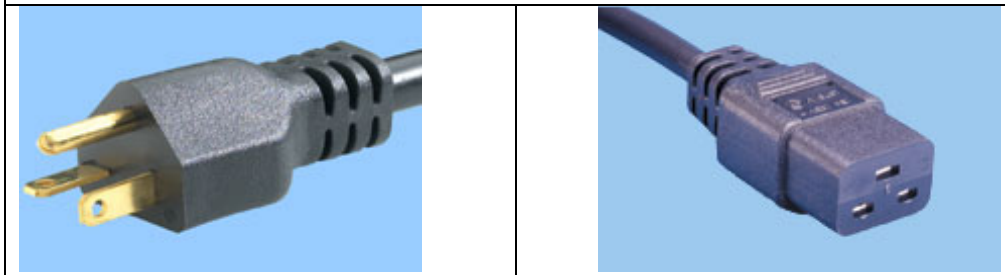
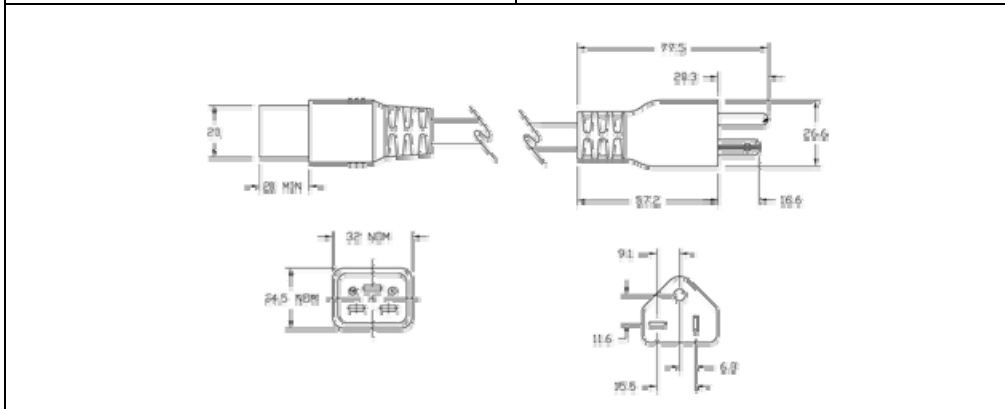

Table 3. Quail Electronics* North American Cordset 250VAC

Part Number	5083.098
Contact Telephone Number	1-925-373-6700
Vendor Website	http://www.quail.com/
Equipment End	IEC 60320 C19
Supply End	NEMA L6-15P
Current Rating	15A
Voltage Rating	250VAC



Length	8'2"
	

Table 4. Quail Electronics North American Cordset 125VAC

Part Number	5052.098
Contact Telephone Number	1-925-373-6700
Vendor Website	http://www.quail.com/
Equipment End	IEC 60320 C19
Supply End	NEMA 5-20P
Current Rating	20A
Voltage Rating	125VAC
Length	8'2"
	
	

3.3.2 European Power Supply Cordsets

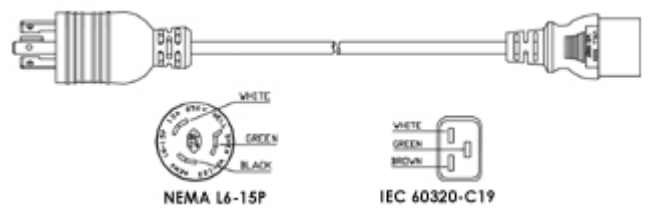
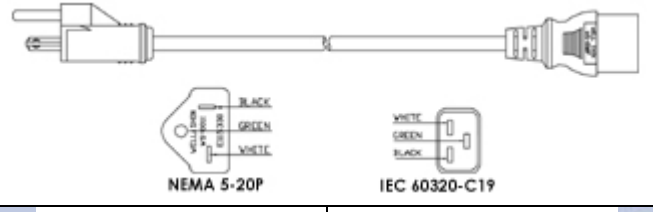
Table 5. Interpower Corporation Continental Europe Cordset

Part Number	86235000
Contact Telephone Number	44 (0) 1908 327700
Vendor Website	http://www.interpower.com/
Equipment End	IEC 60320 C19
Supply End	CEE 7/7
Current Rating	16A
Voltage Rating	250VAC
Length	2.5 meters

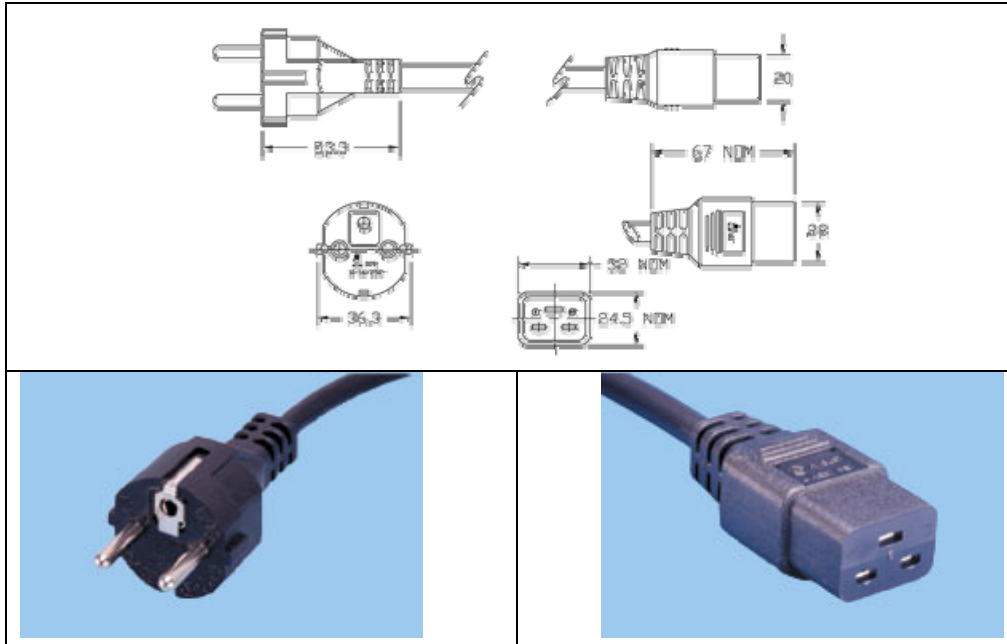

Table 6. Quail Electronics Continental Europe Cordset

Part Number	8504.098
Contact Telephone Number	011-1-800-669-8090
Vendor Website	http://www.quail.com/
Equipment End	IEC 60320 C19
Supply End	CEE 7/7 (Schuko)
Current Rating	15A
Voltage Rating	250VAC
Length	2.5 meters

3.3.3 Chinese Power Supply Cordsets

Table 7. Quail Electronics Chinese Cordset

Part Number	8591.098
Contact Telephone Number	011-1-800-669-8090
Vendor Website	http://www.quail.com/
Equipment End	IEC 60320 C19
Supply End	GB 2099-1-1996
Current Rating	16A
Voltage Rating	250VAC

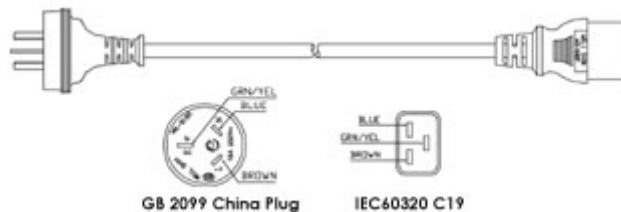
Length	2.5 meters
 <p>GB 2099 China Plug IEC60320 C19</p>	

3.3.4 United Kingdom Power Supply Cordsets

Table 8. Interpower Corporation United Kingdom Cordset

Part Number	86240250
Contact Telephone Number	44 (0) 1908 327700
Vendor Website	http://www.interpower.com/
Equipment End	IEC 60320 C19
Supply End	U.K. Plug BS 1363
Current Rating	13A
Voltage Rating	250 VAC
Length	2.5 meters
 <p>Plug contains 13-amp Fuse</p>	
	

Table 9. Quail Electronics United Kingdom Cordset

Part Number	9656.098
Contact Telephone Number	011-1-800-669-8090
Vendor Website	http://www.quail.com/
Equipment End	IEC 60320 C19
Supply End	U.K. Plug BS 1363

Current Rating	15A
Voltage Rating	250VAC
Length	2.5 meters

3.3.5 Russia Power Supply Cordsets

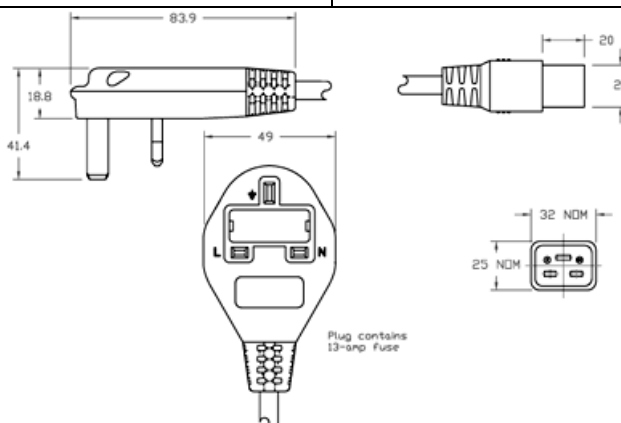
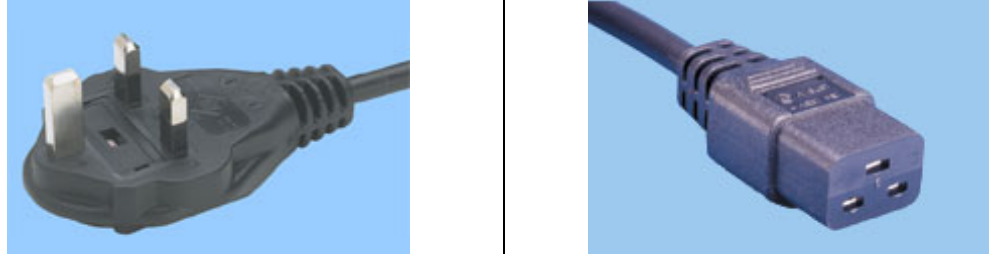
Table 10. Incoll* Incorporated Russia Cordset

Part Number	311-9321
Contact Telephone Number	8-343-375-38-08
Vendor Website	www.incoll.russia.com
Equipment End	IEC 60320 C19
Supply End	CEE 7/7 (Schuko)
Current Rating	16A
Voltage Rating	250 VAC
Length	2 meters