

Intel® Server Board SE7320VP2 User Guide

Order Number: C71354-002

Disclaimer

Information in this document is provided in connection with Intel® products. No license, express or implied, by estoppel or otherwise, to any intellectual property rights is granted by this document. Except as provided in Intel's Terms and Conditions of Sale for such products, Intel assumes no liability whatsoever, and Intel disclaims any express or implied warranty, relating to sale and/or use of Intel products including liability or warranties relating to fitness for a particular purpose, merchantability, or infringement of any patent, copyright or other intellectual property right. Intel products are not designed, intended or authorized for use in any medical, life saving, or life sustaining applications or for any other application in which the failure of the Intel product could create a situation where personal injury or death may occur. Intel may make changes to specifications and product descriptions at any time, without notice.

Intel server boards contain a number of high-density VLSI and power delivery components that need adequate airflow for cooling. Intel's own chassis are designed and tested to meet the intended thermal requirements of these components when the fully integrated system is used together. It is the responsibility of the system integrator that chooses not to use Intel developed server building blocks to consult vendor datasheets and operating parameters to determine the amount of airflow required for their specific application and environmental conditions. Intel Corporation can not be held responsible if components fail or the server board does not operate correctly when used outside any of their published operating or non-operating limits.

Intel, Intel Pentium, and Intel Xeon are trademarks or registered trademarks of Intel Corporation or its subsidiaries in the United States and other countries.

* Other names and brands may be claimed as the property of others.

Copyright © 2004, Intel Corporation. All Rights Reserved

Preface

About this Manual

Thank you for purchasing and using the Intel® Server Board SE7320VP2.

This manual is written for system technicians who are responsible for troubleshooting, upgrading, and repairing this server board. This document provides a brief overview of the features of the board/chassis, a list of accessories or other components you may need, troubleshooting information, and instructions on how to add and replace components on the Intel Server Board SE7320VP2. For the latest version of this manual, refer to <http://support.intel.com/support/motherboards/server/SE7320VP2/>.

Manual Organization

Chapter 1 provides a brief overview of the Server Board SE7320VP2. In this chapter, you will find a list of the server board features, photos of the product, and product diagrams to help you identify components and their locations.

Chapter 2 provides instructions on adding and replacing components. Use this chapter for step-by-step instructions and diagrams for installing or replacing components such as the memory, processor, control panel board, and the battery, among other components.

Chapter 3 provides instructions on using the utilities that are shipped with the board or that may be required to update the system. This includes how to navigate through the BIOS Setup screens, how to perform a BIOS update, and how to reset the password or CMOS. Information about the specific BIOS settings and screens is available in the Technical Product Specification. See “[Additional Information and Software](#)” for a link to the Technical Product Specification.

Chapter 4 provides troubleshooting information. In this chapter, you will find BIOS error messages and POST code messages. You will also find suggestions for performing troubleshooting activities to identify the source of a problem.

Product Accessories

This server board is compatible with the following Intel® Server Chassis:

- Intel® Server Chassis SR2400
- Intel® Server Platform SR1435VP2

You may need or want to purchase one or more of the following accessory items for your server:

Processor, memory DIMMs, hard drive, floppy drive, CD-ROM or DVD-ROM drive, RAID controller, operating system.

For information about which accessories, memory, processors, and third-party hardware have been tested and can be used with your board, and for ordering information for Intel products, see <http://support.intel.com/support/motherboards/server/SE7320VP2/>.

Additional Information and Software

If you need more information about this product or information about the accessories that can be used with this server board, use the following resources. These files are available at

<http://support.intel.com/support/motherboards/server/SE7320VP2>

Unless otherwise indicated in the table below, once on this Web page, type the document or software name in the search field at the **left** side of the screen and select the option to search “This Product.”

For this information or software	Use this search criteria or look at this document
For in-depth technical information about this product, including BIOS settings and chipset information	Search for “Technical Product Specification”
If you just received this product and need to install it	See the Intel® Server Board SE7320VP2 Quick Start User’s Guide in the product box
For virtual system tours and interactive repair information	Use the link to the SMaRT Tool under “Other Resources” at the right side of the screen at http://support.intel.com/support/motherboards/server/SE7320VP2
Accessories or other Intel server products	Search for “Spares and Configuration Guide”
Hardware (peripheral boards, adapter cards) and operating systems that have been tested with this product	Search for “Tested Hardware and Operating System List”
Chassis that have been tested with this product	Search for “Reference Chassis List”
Processors that have been tested with this product	Search for “Supported Processors”
DIMMs that have been tested with this product	Search for “Supported Memory”
To make sure your system falls within the allowed power budget	Search for “Power Budget”
For software to manage your Intel® server	Search for “Intel Server Management”
For drivers	Search for “Driver” (for an extensive list of drivers available) Search for “Operating System Driver” (for operating system drivers)
For firmware and BIOS updates	Search for “Firmware Update”
For diagnostics test software	Search for “Diagnostics”

Safety Information



WARNING

Before working with your server product, whether you are using this guide or any other resource as a reference, pay close attention to the safety instructions. You must adhere to the assembly instructions in this guide to ensure and maintain compliance with existing product certifications and approvals. Use only the described, regulated components specified in this guide. Use of other products / components will void the UL listing and other regulatory approvals of the product and will most likely result in noncompliance with product regulations in the region(s) in which the product is sold.

Emissions Disclaimer

To ensure EMC compliance with your local regional rules and regulations, the final configuration of your end system product may require additional EMC compliance testing. For more information please contact your local Intel Representative.

See “[Regulatory and Integration Information](#)” for product safety compliance and EMC regulatory compliance information. This is an FCC Class A device. Integration of it into a Class B chassis does not result in a Class B device.

Intended Uses

This product was evaluated as Information Technology Equipment (ITE), which may be installed in offices, schools, computer rooms, and similar commercial type locations. The suitability of this product for other product categories and environments (such as: medical, industrial, telecommunications, NEBS, residential, alarm systems, test equipment, etc.), other than an ITE application, may require further evaluation

EMC Testing

Before computer integration, make sure that the chassis, power supply, and other modules have passed EMC testing using a server board with a microprocessor from the same family (or higher) and operating at the same (or higher) speed as the microprocessor used on this server board.



Warnings

System power on/off: The power button DOES NOT turn off the system AC power. To remove power from system, you must unplug the AC power cord from the wall outlet. Make sure the AC power cord is unplugged before you open the chassis, add, or remove any components.

Hazardous conditions, devices and cables: Hazardous electrical conditions may be present on power, telephone, and communication cables. Turn off the server and disconnect the power cord, telecommunications systems, networks, and modems attached to the server before opening it. Otherwise, personal injury or equipment damage can result.

Electrostatic discharge (ESD) and ESD protection: ESD can damage disk drives, boards, and other parts. We recommend that you perform all procedures in this chapter only at an ESD workstation. If one is not available, provide some ESD protection by wearing an antistatic wrist strap attached to chassis ground any unpainted metal surface on your server when handling parts.

ESD and handling boards: Always handle boards carefully. They can be extremely sensitive to ESD. Hold boards only by their edges. After removing a board from its protective wrapper or from the server, place the board component side up on a grounded, static free surface. Use a conductive foam pad if available but not the board wrapper. Do not slide board over any surface.

Installing or removing jumpers: A jumper is a small plastic encased conductor that slips over two jumper pins. Some jumpers have a small tab on top that you can grip with your fingertips or with a pair of fine needle nosed pliers. If your jumpers do not have such a tab, take care when using needle nosed pliers to remove or install a jumper; grip the narrow sides of the jumper with the pliers, never the wide sides. Gripping the wide sides can damage the contacts inside the jumper, causing intermittent problems with the function controlled by that jumper. Take care to grip with, but not squeeze, the pliers or other tool you use to remove a jumper, or you may bend or break the pins on the board.

Safety Cautions

Read all caution and safety statements in this document before performing any of the instructions. See also *Intel Server Boards and Server Chassis Safety Information* on the Resource CD and/or at <http://support.intel.com/support/motherboards/server/>.

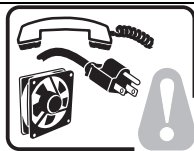

SAFETY STEPS: Whenever you remove the chassis covers to access the inside of the system, follow these steps:

1. Turn off all peripheral devices connected to the system.
2. Turn off the system by pressing the power button.
3. Unplug all AC power cords from the system or from wall outlets.
4. Label and disconnect all cables connected to I/O connectors or ports on the back of the system.
5. Provide some electrostatic discharge (ESD) protection by wearing an antistatic wrist strap attached to chassis ground of the system—any unpainted metal surface—when handling components.
6. Do not operate the system with the chassis covers removed.

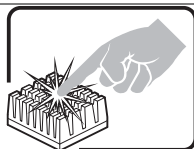

A microprocessor and heat sink may be hot if the system has been running. Also, there may be sharp pins and edges on some board and chassis parts. Contact should be made with care. Consider wearing protective gloves.

Wichtige Sicherheitshinweise

Lesen Sie zunächst sämtliche Warn- und Sicherheitshinweise in diesem Dokument, bevor Sie eine der Anweisungen ausführen. Beachten Sie hierzu auch die Sicherheitshinweise zu Intel-Serverplatinen und -Servergehäusen auf der Ressourcen-CD oder unter <http://support.intel.com/support/motherboards/server/>.



SICHERHEISSMASSNAHMEN: Immer wenn Sie die Gehäuseabdeckung abnehmen um an das Systeminnere zu gelangen, sollten Sie folgende Schritte beachten:

1. Schalten Sie alle an Ihr System angeschlossenen Peripheriegeräte aus.
2. Schalten Sie das System mit dem Hauptschalter aus.
3. Ziehen Sie den Stromanschlußstecker Ihres Systems aus der Steckdose.
4. Auf der Rückseite des Systems beschrifteten und ziehen Sie alle Anschlußkabel von den I/O Anschlüssen oder Ports ab.
5. Tragen Sie ein geerdetes Antistatik Gelenkband, um elektrostatische Ladungen (ESD) über blanke Metallstellen bei der Handhabung der Komponenten zu vermeiden.
6. Schalten Sie das System niemals ohne ordnungsgemäß montiertes Gehäuse ein.

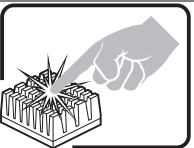

Der Mikroprozessor und der Kühler sind möglicherweise erhitzt, wenn das System in Betrieb ist. Außerdem können einige Platinen und Gehäuseteile scharfe Spitzen und Kanten aufweisen. Arbeiten an Platinen und Gehäuse sollten vorsichtig ausgeführt werden. Sie sollten Schutzhandschuhe tragen.

重要安全指导

在执行任何指令之前，请阅读本文档中的所有注意事项及安全声明。参见 Resource CD（资源光盘）和/或 <http://support.intel.com/support/motherboards/server/> 上的 *Intel Server Boards and Server Chassis Safety Information*（《Intel 服务器主板与服务器机箱安全信息》）。

Consignes de sécurité

Lisez attention toutes les consignes de sécurité et les mises en garde indiquées dans ce document avant de suivre toute instruction. Consultez *Intel Server Boards and Server Chassis Safety Information* sur le CD Resource CD ou bien rendez-vous sur le site <http://support.intel.com/support/motherboards/server/>.

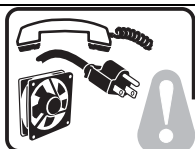

CONSIGNES DE SÉCURITÉ -Lorsque vous ouvrez le boîtier pour accéder à l'intérieur du système, suivez les consignes suivantes:

1. Mettez hors tension tous les périphériques connectés au système.
2. Mettez le système hors tension en mettant l'interrupteur général en position OFF (bouton-poussoir).
3. Débranchez tous les cordons d'alimentation c.a. du système et des prises murales.
4. Identifiez et débranchez tous les câbles reliés aux connecteurs d'E-S ou aux accès derrière le système.
5. Pour prévenir les décharges électrostatiques lorsque vous touchez aux composants, portez une bande antistatique pour poignet et reliez-la à la masse du système (toute surface métallique non peinte du boîtier).
6. Ne faites pas fonctionner le système tandis que le boîtier est ouvert.

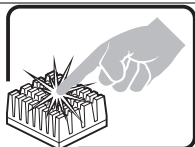

Le microprocesseur et le dissipateur de chaleur peuvent être chauds si le système a été sous tension. Faites également attention aux broches aiguës des cartes et aux bords tranchants du capot. Nous vous recommandons l'usage de gants de protection.

Instrucciones de seguridad importantes

Lea todas las declaraciones de seguridad y precaución de este documento antes de realizar cualquiera de las instrucciones. Vea *Intel Server Boards and Server Chassis Safety Information* en el CD Resource y/o en <http://support.intel.com/support/motherboards/server/>.



INSTRUCCIONES DE SEGURIDAD: Cuando extraiga la tapa del chasis para acceder al interior del sistema, siga las siguientes instrucciones:

1. Apague todos los dispositivos periféricos conectados al sistema.
2. Apague el sistema presionando el interruptor encendido/apagado.
3. Desconecte todos los cables de alimentación CA del sistema o de las tomas de corriente alterna.
4. Identifique y desconecte todos los cables enchufados a los conectores E/S o a los puertos situados en la parte posterior del sistema.
5. Cuando manipule los componentes, es importante protegerse contra la descarga electrostática (ESD). Puede hacerlo si utiliza una muñequera antiestática sujeta a la toma de tierra del chasis — o a cualquier tipo de superficie de metal sin pintar.
6. No ponga en marcha el sistema si se han extraído las tapas del chasis.

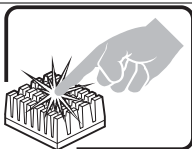

Si el sistema ha estado en funcionamiento, el microprocesador y el disipador de calor pueden estar aún calientes. También conviene tener en cuenta que en el chasis o en el tablero puede haber piezas cortantes o punzantes. Por ello, se recomienda precaución y el uso de guantes protectores.

AVVERTENZA: Italiano



PASSI DI SICUREZZA: Qualora si rimuovano le coperture del telaio per accedere all'interno del sistema, seguire i seguenti passi:

1. Spegner tutti i dispositivi periferici collegati al sistema.
2. Spegner il sistema, usando il pulsante spento/accesso dell'interruttore del sistema.
3. Togliere tutte le spine dei cavi del sistema dalle prese elettriche.
4. Identificare e sconnettere tutti i cavi attaccati ai collegamenti I/O od alle prese installate sul retro del sistema.
5. Qualora si tocchino i componenti, proteggersi dallo scarico elettrostatico (SES), portando un cinghia anti-statica da polso che è attaccata alla presa a terra del telaio del sistema – qualsiasi superficie non dipinta – .
6. Non far operare il sistema quando il telaio è senza le coperture.

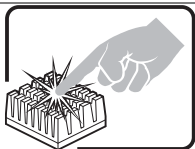

Se il sistema è stato a lungo in funzione, il microprocessore e il dissipatore di calore potrebbero essere surriscaldati. Fare attenzione alla presenza di piedini appuntiti e parti taglienti sulle schede e sul telaio. È consigliabile l'uso di guanti di protezione.

Contents

1	Server Board Features	15
	Connector and Header Locations	17
	Configuration Jumpers	18
	Back Panel Connectors.....	21
	Hardware Requirements	22
	Processor	22
	Memory	22
	Optional Hardware	24
	Storage Devices.....	24
2	Hardware Installations and Upgrades	25
	Before You Begin	25
	Tools and Supplies Needed	25
	Installing and Removing Memory	25
	Installing DIMMs.....	25
	Removing DIMMs.....	27
	Installing or Replacing the Processor.....	28
	Installing the Processor	28
	Removing a Processor	30
	RJ45 Serial Port Configuration.....	31
	Installing a PCI, PCI-X, or PCI-Express* Add-in Card	32
	Replacing the Backup Battery.....	32
3	Server Utilities	34
	Using the BIOS Setup Utility	34
	Starting Setup	34
	If You Cannot Access Setup	34
	Setup Menus	34
	Upgrading the BIOS	36
	Preparing for the Upgrade.....	36
	Upgrading the BIOS	37
	Clearing the Password.....	37
	Clearing the CMOS.....	38
4	Troubleshooting	39
	Resetting the System.....	39
	Problems following Initial System Installation	40
	First Steps Checklist.....	40
	Hardware Diagnostic Testing.....	41
	Verifying Proper Operation of Key System Lights	41
	Confirming Loading of the Operating System	41
	Specific Problems and Corrective Actions	42
	Power Light Does Not Light.....	42
	No Characters Appear on Screen	43

Contents

Characters Are Distorted or Incorrect.....	43
System Cooling Fans Do Not Rotate Properly	44
Diskette Drive Activity Light Does Not Light.....	44
CD-ROM Drive or DVD-ROM Drive Activity Light Does Not Light	45
Cannot Connect to a Server.....	45
Problems with Network.....	45
System Boots when Installing PCI Card.....	46
Problems with Newly Installed Application Software.....	46
Problems with Application Software that Ran Correctly Earlier.....	46
Devices are not Recognized under Device Manager (Windows* Operating System)..	47
Hard Drive(s) are not Recognized.....	47
Bootable CD-ROM Is Not Detected.....	47
LED Information	48
Product Regulatory Compliance	49
Product Safety Compliance.....	49
Product EMC Compliance – Class A Compliance.....	49
Certifications / Registrations / Declarations.....	50
Product Regulatory Compliance Markings.....	50
Electromagnetic Compatibility Notices.....	51
FCC (USA)	51
Industry Canada (ICES-003).....	52
Europe (CE Declaration of Conformity).....	52
Taiwan Declaration of Conformity (BSMI).....	52
Korean Compliance (RRL)	52
Getting Help	53
Intel® Server Issue Report Form.....	55
Figures	
Figure 1. Intel® Server Board SE7320VP2.....	15
Figure 2. Server Board Connector and Header Locations.....	17
Figure 3. Recovery Jumper Location	18
Figure 4. Serial Port Configuration Jumper Location	19
Figure 5. BIOS Select Jumper Location.....	20
Figure 6. Back Panel Connectors	21
Figure 7. Installing Memory.....	26
Figure 8. Opening Socket Lever	28
Figure 9. Inserting Processor.....	29
Figure 10. Closing Socket Lever.....	29
Figure 11. Installing Heat Sink	30
Figure 12. Changing the Serial Port Configuration	31
Figure 13. Replacing the Backup Battery	33
Figure 14. Password Recovery Jumper.....	37
Figure 15. CMOS Recovery Jumper.....	38

Tables

Table 1.	Server Board Features	16
Table 2.	Recovery Jumper [J1H2, J1H3, J1H5]	18
Table 3.	Serial Port Configuration Jumper [J8A3]	19
Table 4.	BIOS Select Jumper [J1A4]	20
Table 5.	NIC LEDs.....	21
Table 6.	Processor Support.....	22
Table 7.	Memory Capacity Support	23
Table 8.	Keyboard Commands.....	35
Table 9.	Keyboard Commands.....	48
Table 10.	Product Certification Markings.....	50
Table 11.	Customer Support Telephone Numbers.....	53

Contents

1 Server Board Features

This chapter briefly describes the main features of Intel® Server Board SE7320VP2. This chapter provides a photograph of the product, a list of the server board features, and diagrams showing the location of important components and connections on the server board.

The Server Board SE7320VP2 is shown in the following picture.

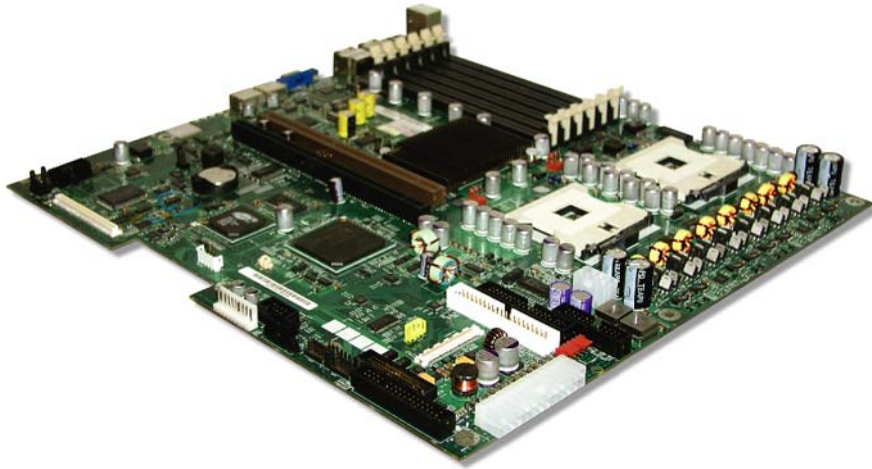

Figure 1. Intel® Server Board SE7320VP2

Table 1 summarizes the major features of the server board.

Table 1. Server Board Features

Feature	Description
Processors	Support for up to two Intel® Xeon™ processors with an 800 MT/s MHz front side bus and frequencies starting at 2.8 GHz.
Memory	Six DIMM slots supporting DDR266MHz or DDR333MHz memory Memory mirroring and memory sparing options
Chipset	Intel® E7320 chipset, including: <ul style="list-style-type: none"> ▪ Intel E7320 MCH ▪ Intel 6300ESB ICH
I/O Control	External connections: <ul style="list-style-type: none"> ▪ Stacked PS/2 ports for keyboard and mouse ▪ RJ45 Serial B port ▪ Two RJ45 NIC connectors for 10/100/1000 Mb connections ▪ Two USB 2.0 ports ▪ One USB port header, which supports two USB ports ▪ One DH10 Serial A header ▪ Two SATA-100 connectors with integrated RAID 0/1 support ▪ One ATA100 connector ▪ SSI-compliant and custom front panel headers ▪ SSI-compliant 24-pin main power connector, supporting the ATX-12V standard on the first 20 pins.
Add-in PCI, PCI-X, PCI-Express* Cards (riser(s) required)	<ul style="list-style-type: none"> ▪ One low-profile riser connector that supports a riser card with a PCI or PCI-X slot that is capable of speeds up to 66 MHz. ▪ One full-height riser connector, utilizing Intel® Adaptive Slot technology. This connector supports a riser card with PCI, PCI-X, and/or PCI-Express* slots.
Video	On-board ATI* RAGE XL video controller with 8MB SDRAM
Hard Drive	Ultra ATA/100 support: <ul style="list-style-type: none"> ▪ Two IDE channels that support either one or two drives SATA support <ul style="list-style-type: none"> ▪ Two SATA ports ▪ RAID level 0/1 support
LAN	Two 10/100/1000 NICs
Fans	Four SSI-compliant 3-pin fan connectors <ul style="list-style-type: none"> ▪ Two processor fan connectors ▪ Two PCI fan connectors One 20-pin fan connector to provide power and management of system fans in the Intel® Server Chassis SR2400 and in the Intel® Server Platform SR1435VP2
Server Management	<ul style="list-style-type: none"> ▪ On-board Essentials server management ▪ Support for Intel® Server Management 8

Connector and Header Locations

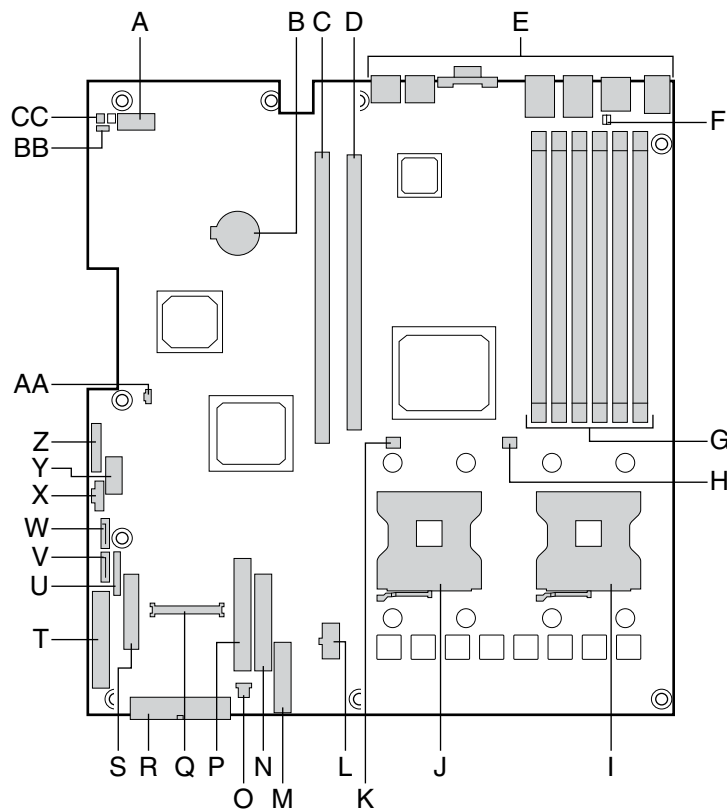

TP00941

A	Serial Port A header	K	Processor 2 fan header	U	Configuration jumpers
B	Battery	L	+12V processor power connector	V	SATA 1 connector
C	Full-height PCI slot	M	Fan board connector	W	SATA 0 connector
D	Low-profile PCI slot	N	Floppy connector	Z	Power supply connector
E	Back panel I/O ports	O	PCI fan connectors (two)	Y	OEM RMC connector
F	Serial port selection jumper	P	IDE connector	Z	Front panel USB header
G	DIMM sockets	Q	100-pin Floppy / Front Panel / ATA connector	AA	IDE power connector
H	Processor 1 fan header	R	Main power connector	BB	BIOS Select jumper
I	Processor 1 socket	S	50-pin front panel connector	CC	Chassis intrusion header
J	Processor 2 socket	T	34-pin front panel connector		

Figure 2. Server Board Connector and Header Locations

Configuration Jumpers

Recovery Jumpers

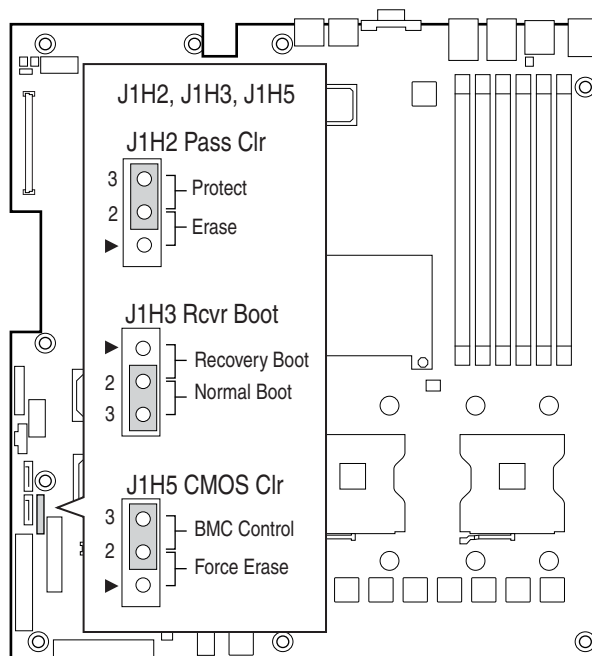

TP00942

Figure 3. Recovery Jumper Location

Table 2. Recovery Jumper [J1H2, J1H3, J1H5]

Jumper Name	Pins	What happens at system reset...
J1H2: Password Clear	1-2	If these pins are jumpered, administrator and user passwords will be cleared on the next reset. These pins should not be jumpered for normal operation.
	2-3	These pins should be jumpered for normal system operation.
J1H3: Recovery Boot	1-2	If these pins are jumpered, the system will attempt to recover the BIOS by loading the BIOS code into the flash device from a floppy disk. This jumper is typically used when the BIOS has become corrupted. These pins should not be jumpered for normal operation.
	2-3	These pins should be jumpered for normal system operation.
J1H5: CMOS Clear	1-2	If these pins are jumpered, the CMOS settings will be cleared on the next reset. These pins should not be jumpered for normal operation.
	2-3	These pins should be jumpered for normal system operation.

Serial Port Configuration Jumper

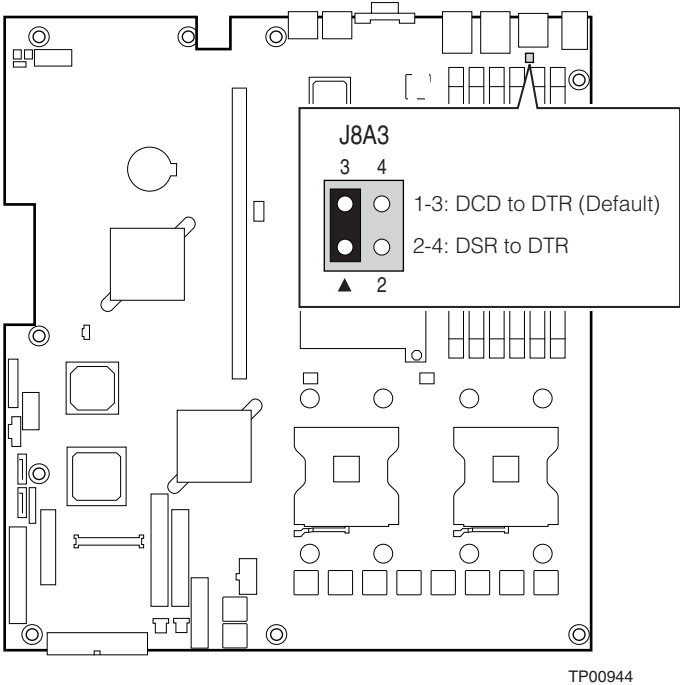

Figure 4. Serial Port Configuration Jumper Location

Table 3. Serial Port Configuration Jumper [J8A3]

Pins	What happens at system reset...
1-3	Serial port is configured for DCD to DTR (default)
2-4	Serial port is configured for DSR to DTR.

BIOS Select Jumper

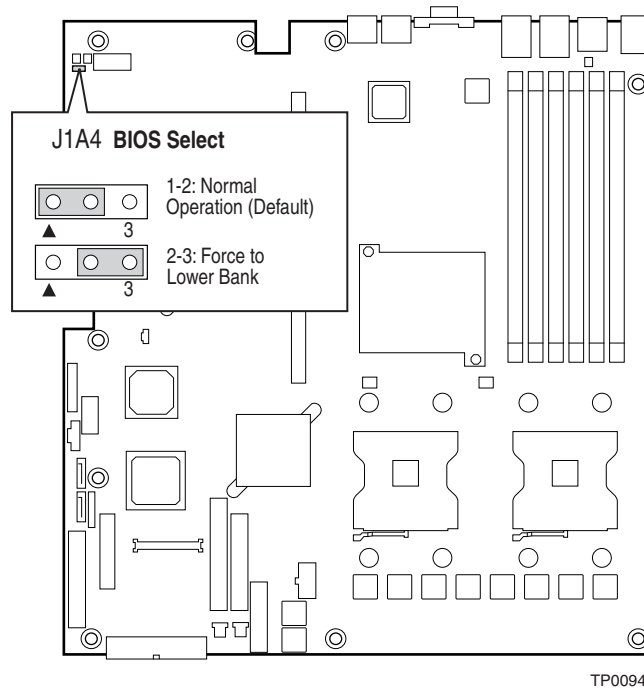

Figure 5. BIOS Select Jumper Location

Table 4. BIOS Select Jumper [J1A4]

Pins	What happens at system reset...
1-2	System is configured for normal operation
2-3	Force BIOS to lower bank

Back Panel Connectors

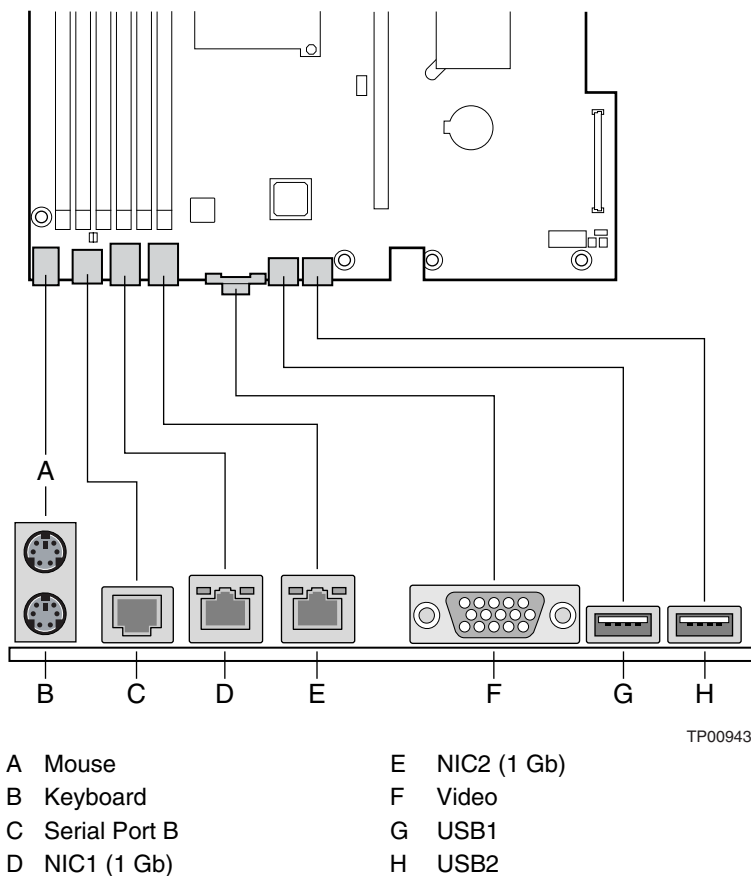

Figure 6. Back Panel Connectors

The NIC LEDs at the right and left of each NIC provide the following information.

Table 5. NIC LEDs

LED Color	LED State	Description
Left LED	Off	No network connection
	Solid Amber	Network connection in place
	Blinking Amber	Transmit/receive activity
Right LED	Off	10 Mbps connection (if left LED is on or blinking)
	Solid Amber	100 Mbps connection
	Solid Green	1000 Mbps connection

Hardware Requirements

To avoid integration difficulties and possible board damage, your system must meet the requirements outlined below. For a list of qualified components, see the links under “[Additional Information and Software](#).”

Processor

One or two Intel® Xeon™ processors with an 800MHz front side bus and a minimum of 2.8 GHz frequency must be installed. The following table outlines the supported processors. For a complete list of supported processors, see the links under “[Additional Information and Software](#).”

Table 6. Processor Support

Processor Family	FSB Frequency	Frequency
Intel® Xeon™	800 MHz	2.8 GHz
Intel® Xeon™	800 MHz	3.0 GHz
Intel® Xeon™	800 MHz	3.2 GHz
Intel® Xeon™	800 MHz	3.4 GHz
Intel® Xeon™	800 MHz	3.6 GHz

Memory

The Server Board SE7320VP2 provides six DIMM sockets across two channels, Channel A and Channel B. Channel A consists of DIMM sockets 1A, 2A, and 3A. Channel B consists of DIMM sockets 1B, 2B, and 3B.

If six DIMMs are installed, the following maximum capacities are possible:

- For DDR266 DIMMS: Maximum capacity of 24GB
- For DDR333 DIMMS: Maximum capacity of 16 GB
- A minimum of one 256MB DIMM is required in DIMM socket 1A. This uses single-channel interleave. However, for dual-channel interleave, providing optimum performance, a minimum of two DIMMs should be installed in DIMM sockets 1A and 1B. Except for the option of installing a single DIMM in socket 1A, DIMMs must be installed in pairs and populated as follows:
 - DIMM1A and DIMM 1B: Populate these two sockets together first
 - DIMM 2A and DIMM 2B: Populate these sockets in addition to DIMM 1A and DIMM 2A if four DIMMs are to be used.
 - DIMM 3A and DIMM 3B: Populate these sockets after DIMM 1A, DIMM 1B, DIMM 2A, and DIMM 2B have been populated.

DIMMs must meet the following requirements:

- Use only DDR266 or DDR33, registered DDR DIMM modules
- Use only DIMMs that comply with the DDR specifications.
- DDR266 and DDR333 memory can be mixed on the server board, but when mixing DIMM types, DDR333 memory will be treated as DDR266.
- Use only DIMMs with DIMM organization of x72 ECC
- Use only 184-pin DIMMs
- Use only DIMMs with the capacities outlined in the following table

Table 7. Memory Capacity Support

DIMM Type	256MB	512MB	1GB
X8, single row	256MB	512MB	1GB
X8, double row	512MB	1GB	2GB
X4, single row	512MB	1GB	2GB
X4, stacked, double row	1GB	2GB	4GB

In determining your memory requirements, the need for memory sparing or memory mirroring must be considered. For a complete list of supported memory DIMMs, see the links under “[Additional Information and Software](#).”

Memory Sparing and Mirroring

The Intel® E7320 chipset supports memory mirroring and memory on-line sparing. Both memory mirroring and memory on-line sparing provide a way to prevent data loss in case a DIMM fails.

With memory mirroring the system maintains two copies of all data in the memory subsystem. If a DIMM fails, the data is not lost because the second copy of the data is available from the mirrored DIMM in the opposite channel. The system will not fail due to memory error unless both the primary and the mirrored copy of the data become corrupt at the same time.

In a mirrored system, the maximum usable memory space is one-half of the installed memory, with a minimum of four DIMMs installed.

One method for memory mirroring is available, with four identical DIMMs are used in DIMM sockets 1A, 1B, 2A, and 2B.

- If the DIMM in socket 1A fails, the DIMM in socket 2B takes over.
- If the DIMM in socket 1B fails, the DIMM in socket 2A takes over.

For memory on-line sparing, one DIMM per channel is used as the memory spare. The spare DIMM is not available for use, but is kept in reserve. If a DIMM begins to fail, the content of the failing DIMM is copied to the spare DIMM in that channel. When all of the data is copied to the spare DIMM, the primary DIMM is removed from service and the spare DIMM takes its place.

When memory on-line sparing is used, the spare DIMMs must be equal to or larger than the largest in-service DIMM in that channel.



NOTE

Memory mirroring and memory sparing are mutually exclusive. Only one can be active at a time. Refer to the *Intel® Server Board SE7320VP2 Technical Product Specification* for additional information regarding the memory sub-system.

Power Supply

A minimum of 450 Watts is required. Your supply must provide a minimum of 1.2 A of 5 V standby current or the board will not boot. Use the power budget tool to determine the minimum power supply for your system, based on all installed components. For a link to the power budget utility, see “[Additional Information and Software](#).”

Optional Hardware

Storage Devices

The Server Board SE7320VP2 provides two SATA connections and two ATA (IDE/ATAPI) controllers. The two SATA connectors are on the powersupply side of the board marked “SATA 0” and “SATA 1”. Each ATA connection supports one or two ATA/100 devices. IDE devices can be connected to the standard ATA connector, next to the floppy connector, or to the 100-pin cable connector.

A floppy drive connection is available through the standard floppy connector or through the 100-pin front panel connector if you have installed the optional hot-swap backplane.

Drive power is supplied from the chassis power supply for conventional cable-attached drives. Power is available from the IDE power header near the cutout in the center on the power supply side of the board for ATA-compliant IDE flash drives (mini IDE, iDiskOnChip*, and others). For multiple slimline devices a Y-cable for power can be used. For direct-plug IDE flash drives, use the AXXFLASHPWR accessory cable.

See the documentation included with your server chassis for additional drive information and drive installation instructions.

2 Hardware Installations and Upgrades

Before You Begin

Before working with your server product, pay close attention to the Safety Information at the beginning of this manual.

Tools and Supplies Needed

- Phillips* (cross head) screwdriver (#1 bit and #2 bit)
- Flat-head screwdriver if replacing the battery
- Pen or pencil to write down BIOS settings
- Antistatic wrist strap and conductive foam pad (recommended)

Installing and Removing Memory

The silkscreen on the board for the DIMMs displays DIMM1B, DIMM1A, DIMM2B, DIMM2A, DIMM3B, and DIMM3A, starting from the edge of the board. DIMM3A is the socket closest to the processor socket. See [“Memory”](#) for a discussion of the memory requirements and options. See [“Additional Information and Software”](#) for a link to the list of tested DIMMs.

Installing DIMMs

To install DIMMs, follow these steps:

1. Observe the safety and ESD precautions at the beginning of this book.
2. Turn off all peripheral devices connected to the server. Turn off the server.
3. Disconnect the AC power cord from the server.

4. Remove the server's cover. See the documentation that accompanied your server chassis for instructions on removing the server's cover.
5. Locate the DIMM sockets (see Figure 7).

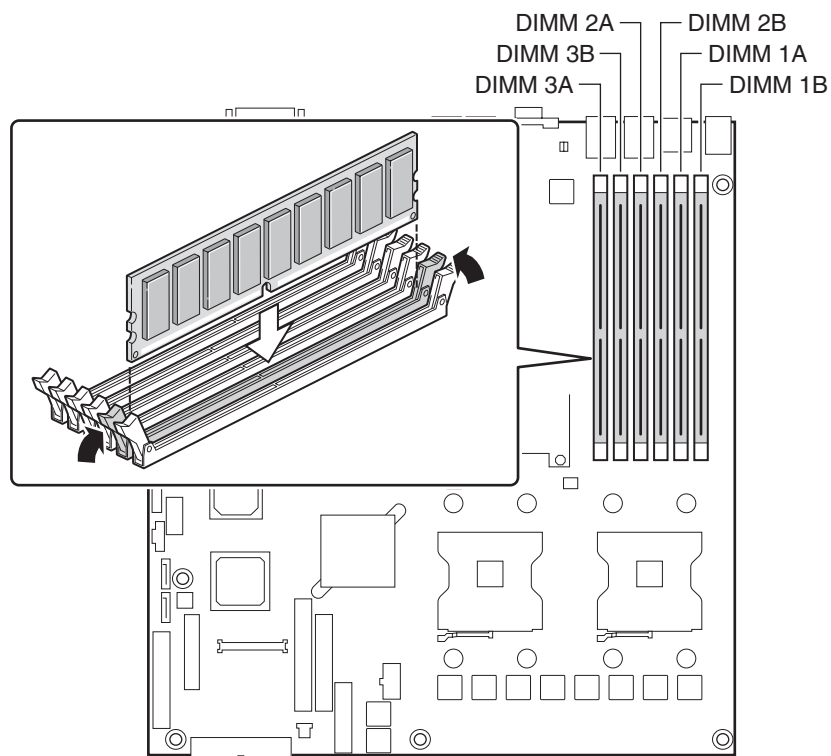

TP00761

Figure 7. Installing Memory

6. Make sure the clips at either end of the DIMM socket(s) are pushed outward to the open position.
7. Holding the DIMM by the edges, remove it from its anti-static package.
8. Position the DIMM above the socket. Align the two small notches in the bottom edge of the DIMM with the keys in the socket (see inset in Figure 7).
9. Insert the bottom edge of the DIMM into the socket.
10. When the DIMM is inserted, push down on the top edge of the DIMM until the retaining clips snap into place. Make sure the clips are firmly in place.
11. Replace the server's cover and reconnect the AC power cord. See the documentation that accompanied your server chassis for instructions on installing the server's cover.

Removing DIMMs

To remove a DIMM, follow these steps:

1. Observe the safety and ESD precautions at the beginning of this book.
2. Turn off all peripheral devices connected to the server. Turn off the server.
3. Remove the AC power cord from the server.
4. Remove the server's cover. See the documentation that accompanied your server chassis for instructions on removing the server's cover.
5. Gently spread the retaining clips at each end of the socket. The DIMM lifts from the socket.
6. Holding the DIMM by the edges, lift it from the socket, and store it in an anti-static package.
7. Reinstall and reconnect any parts you removed or disconnected to reach the DIMM sockets.
8. Replace the server's cover and reconnect the AC power cord. See the documentation that accompanied your server chassis for instructions on installing the server's cover.

Installing or Replacing the Processor



CAUTIONS

Processor must be appropriate: You may damage the server board if you install a processor that is inappropriate for your server. See “[Additional Information and Software](#)” for a link to the list of compatible processor(s).

ESD and handling processors: Reduce the risk of electrostatic discharge (ESD) damage to the processor by doing the following: (1) Touch the metal chassis before touching the processor or server board. Keep part of your body in contact with the metal chassis to dissipate the static charge while handling the processor. (2) Avoid moving around unnecessarily.

Installing the Processor

To install a processor, follow these instructions:

1. Observe the safety and ESD precautions at the beginning of this book.
2. Turn off all peripheral devices connected to the server. Turn off the server.
3. Disconnect the AC power cord from the server.
4. Remove the server’s cover. See the documentation that accompanied your server chassis for instructions on removing the server’s cover
5. Locate the processor socket and raise the socket handle completely (see Figure 8).

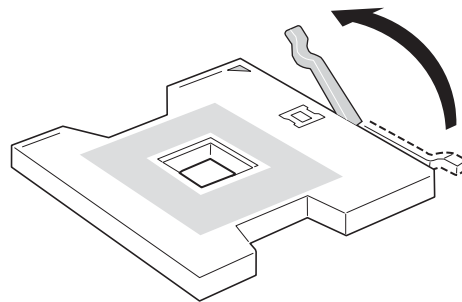

TP00763

Figure 8. Opening Socket Lever

- Align the pins of the processor with the socket, and insert the processor into the socket.

**NOTE**

Make sure the alignment triangle mark and the alignment triangle cutout align correctly.

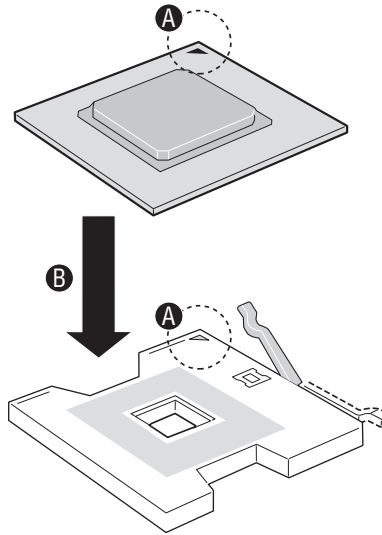

TP00764

Figure 9. Inserting Processor

- Lower the socket lever completely.

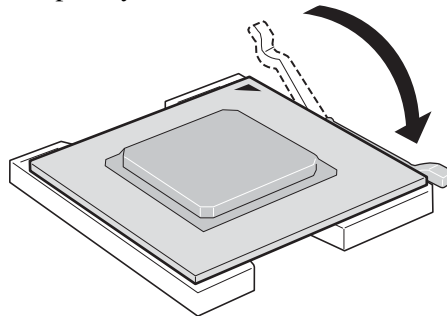

TP00765

Figure 10. Closing Socket Lever

Installing the Heat Sink(s)

1. The heat sink has Thermal Interface Material (TIM) located on the bottom of it. Use caution when you unpack the heat sink so you do not damage the TIM.
2. Set the heat sink over the processor, lining up the four captive screws with the four posts surrounding the processor.
3. Loosely screw in the captive screws on the heat sink corners in a diagonal manner (screw in one screw, then the screw located diagonally to the first screw). Do not fully tighten one screw before tightening another.
4. Gradually and equally tighten each captive screw until each is firmly tightened. Do not over-tighten the screws.

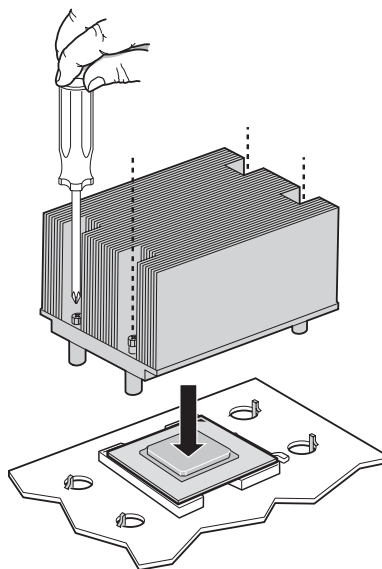

TP00774

Figure 11. Installing Heat Sink

5. Reinstall and reconnect any parts you removed or disconnected to reach the processor sockets.
6. Replace the server's cover and reconnect the AC power cord. See the documentation that accompanied your server chassis for instructions on installing the server's cover.

Removing a Processor

1. Observe the safety and ESD precautions at the beginning of this book.
2. Turn off all peripheral devices connected to the server. Turn off the server.
3. Remove the AC power cord from the server.
4. Remove the server's cover. See the documentation that accompanied your server chassis for instructions on removing the server's cover.
5. Unplug the processor fan cable from the server board.
6. Loosen the four captive screws on the corners of the heat sink.
7. Twist the heat sink slightly to break the seal between the heat sink and the processor.

8. Lift the heat sink from the processor. If it does not pull up easily, twist the heat sink again. Do not force the heat sink from the processor. Doing so could damage the processor.
9. Lift the processor lever.
10. Remove the processor.
11. If installing a replacement processor, see [“Installing the Processor.”](#) Otherwise, reinstall the chassis cover.

RJ45 Serial Port Configuration

The RJ45 serial port connector can be configured to support either a DSR signal or a DCD signal. As the server board is shipped, it is configured to support DSR signals. To change the configuration to support DCD signals a jumper on the board must be changed. Use the following instructions to configure your server board to support DCD signals.

1. Observe the safety and ESD precautions at the beginning of this book.
2. Turn off all peripheral devices connected to the server. Turn off the server.
3. Disconnect the AC power cord from the server.
4. Remove the server’s cover. See the documentation that accompanied your server chassis for instructions on removing the server’s cover.
5. Locate the jumper block for the serial port. See Figure 12.
6. Move the jumper from the default position covering pins 1 and 3 to cover pins 2 and 4.

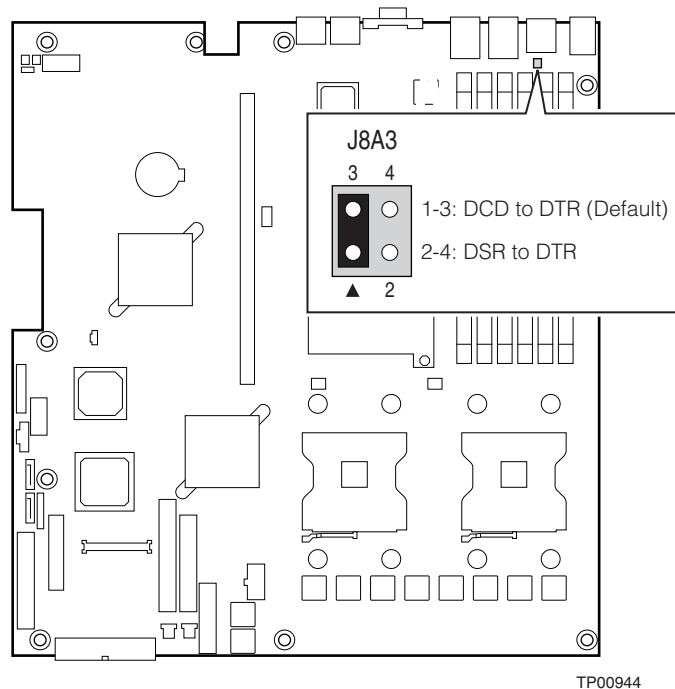

Figure 12. Changing the Serial Port Configuration

Installing a PCI, PCI-X, or PCI-Express* Add-in Card

Add-in cards are not included with your system and must be purchased separately. This server board requires the use of a riser bracket assembly with one or more riser connectors installed on it in order to use a PCI, PCI-X, or PCI-Express add-in card. The riser assembly is typically included with your server chassis. You may need to order the riser connector(s) separately, depending on the server chassis.

See your server chassis documentation for additional requirements and for instructions on installing an add-in card into a riser connector and then installing the assembly into the chassis.

Replacing the Backup Battery

The lithium battery on the server board powers the RTC for up to four to five years in the absence of power. When the battery starts to weaken, it loses voltage, and the server settings stored in CMOS RAM in the RTC (for example, the date and time) may be wrong. Contact your customer service representative or dealer for a list of approved devices.



WARNING

Danger of explosion if battery is incorrectly replaced. Replace only with the same or equivalent type recommended by the equipment manufacturer. Discard used batteries according to manufacturer's instructions.



ADVARSEL!

Lithiumbatteri - Eksplosionsfare ved fejlagtig håndtering. Udskiftning må kun ske med batteri af samme fabrikat og type. Levér det brugte batteri tilbage til leverandøren.



ADVARSEL

Lithiumbatteri - Eksplosjonsfare. Ved utskifting benyttes kun batteri som anbefalt av apparatfabrikanten. Brukt batteri returneres apparatleverandøren.



WARNING

Explosionsfara vid felaktigt batteribyte. Använd samma batterityp eller en ekvivalent typ som rekommenderas av apparattillverkaren. Kassera använt batteri enligt fabrikantens instruktion.



VAROITUS

Paristo voi räjähtää, jos se on virheellisesti asennettu. Vaihda paristo ainoastaan laitevalmistajan suosittelemaan tyyppiin. Hävitä käytetty paristo valmistajan ohjeiden mukaisesti.

1. Observe the safety and ESD precautions at the beginning of this book.
2. Turn off all peripheral devices connected to the server. Turn off the server.
3. Disconnect the AC power cord from the server.
4. Remove the server's cover and locate the battery. See the documentation that accompanied your server chassis for instructions on removing the server's cover.
5. Insert the tip of a small flat bladed screwdriver, or an equivalent, under the tab in the plastic retainer. Gently push down on the screwdriver to lift the battery.
6. Remove the battery from its socket.

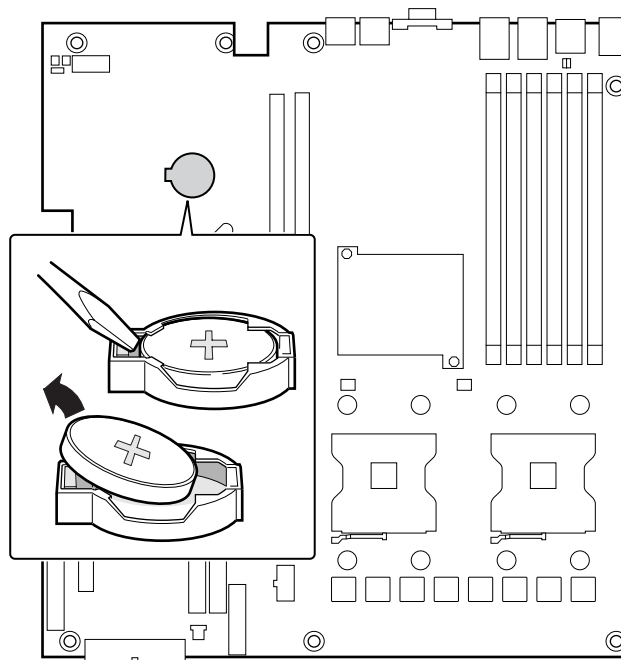

TP00945

Figure 13. Replacing the Backup Battery

7. Dispose of the battery according to local ordinance.
8. Remove the new lithium battery from its package, and, being careful to observe the correct polarity, insert it in the battery socket.
9. Close the chassis.
10. Run Setup to restore the configuration settings to the RTC.

3 Server Utilities

Using the BIOS Setup Utility

This section describes the BIOS Setup Utility options, which is used to change server configuration defaults. You can run BIOS Setup with or without an operating system being present. See [“Additional Information and Software”](#) for a link to the Technical Product Specification where you will find details about specific BIOS setup screens.

Starting Setup

You can enter and start BIOS Setup under several conditions:

- When you turn on the server, after POST completes the memory test
- When you have moved the CMOS jumper on the server board to the “Clear CMOS” position (enabled)

In the two conditions listed above, after rebooting, you will see this prompt:

```
Press <F2> to enter SETUP
```

In a third condition, when CMOS/NVRAM has been corrupted, you will see other prompts but not the <F2> prompt:

```
Warning: CMOS checksum invalid  
Warning: CMOS time and date not set
```

In this condition, the BIOS will load default values for CMOS and attempt to boot.

If You Cannot Access Setup

If you are not able to access BIOS Setup, you might need to clear the CMOS memory. For instructions on clearing the CMOS, see “Clearing the CMOS”.

Setup Menus

Each BIOS Setup menu page contains a number of features. Except for those features that are provided only to display automatically configured information, each feature is associated with a value field that contains user-selectable parameters. These parameters can be changed if the user has adequate security rights. If a value cannot be changed for any reason, the feature’s value field is inaccessible.

Table 8 describes the keyboard commands you can use in the BIOS Setup menus.

Table 8. Keyboard Commands

Press	Description
<F1>	Help - Pressing F1 on any menu invokes the general Help window.
	The left and right arrow keys are used to move between the major menu pages. The keys have no effect if a submenu or pick list is displayed.
	Select Item up - The up arrow is used to select the previous value in a menu item's option list, or a value field pick list. Pressing the Enter key activates the selected item.
	Select Item down - The down arrow is used to select the next value in a menu item's option list, or a value field pick list. Pressing the Enter key activates the selected item.
F5/-	Change Value - The minus key or the F5 function key is used to change the value of the current item to the previous value. This key scrolls through the values in the associated pick list without displaying the full list.
F6/+	Change Value - The plus key or the F6 function key is used to change the value of the current menu item to the next value. This key scrolls through the values in the associated pick list without displaying the full list. On 106-key Japanese keyboards, the plus key has a different scan code than the plus key on the other keyboard, but it has the same effect.
<Enter>	Execute Command - The Enter key is used to activate submenus when the selected feature is a submenu, or to display a pick list if a selected feature has a value field, or to select a sub-field for multi-valued features like time and date. If a pick list is displayed, the Enter key will undo the pick list, and allow another selection in the parent menu.
<Esc>	Exit - The ESC key provides a mechanism for backing out of any field. This key will undo the pressing of the Enter key. When the ESC key is pressed while editing any field or selecting features of a menu, the parent menu is re-entered. When the ESC key is pressed in any submenu, the parent menu is re-entered. When the ESC key is pressed in any major menu, the exit confirmation window is displayed and the user is asked whether changes can be discarded.
<F9>	Setup Defaults - Pressing F9 causes the following to appear: <div style="border: 1px solid black; padding: 5px; margin: 10px auto; width: fit-content;"> <p style="text-align: center;">Setup Confirmation</p> <p style="text-align: center;">Load default configuration now?</p> <p style="text-align: center;">[Yes] [No]</p> </div> <p>If "Yes" is selected and the Enter key is pressed, all Setup fields are set to their default values. If "No" is selected and the Enter key is pressed, or if the ESC key is pressed, the user is returned to where they were before F9 was pressed without affecting any existing field values.</p>
<F10>	Save and Exit - Pressing F10 causes the following message to appear: <div style="border: 1px solid black; padding: 5px; margin: 10px auto; width: fit-content;"> <p style="text-align: center;">Setup Confirmation</p> <p style="text-align: center;">Save Configuration changes and exit now?</p> <p style="text-align: center;">[Yes] [NO]</p> </div> <p>If "Yes" is selected and the Enter key is pressed, all changes are saved and Setup is exited. If "No" is selected and the Enter key is pressed, or the ESC key is pressed, the user is returned to where they were before F10 was pressed without affecting any existing values.</p>

Upgrading the BIOS

The upgrade utility allows you to upgrade the BIOS in flash memory. The code and data in the upgrade file include the following:

- On-board system BIOS, including the recovery code, BIOS Setup Utility, and strings.
- On-board video BIOS and other option ROMs for devices embedded on the server board.
- OEM binary area
- Microcode
- A means to change the BIOS Language

Preparing for the Upgrade

The steps below explain how to prepare to upgrade the BIOS, including how to record the current BIOS settings and how to obtain the upgrade utility.

Recording the Current BIOS Settings

1. Boot the computer and press <F2> when you see the message:
`Press <F2> Key if you want to run SETUP`
2. Write down the current settings in the BIOS Setup program.

NOTE

Do not skip step 2. You will need these settings to configure your computer at the end of the procedure.

Obtaining the Upgrade

Download the BIOS image file to a temporary folder on your hard drive. See “[Additional Information and Software](#)” for a link to the update software.

NOTE

Review the instructions and release notes that are provided in the readme file distributed with the BIOS image file before attempting a BIOS upgrade. The release notes contain critical information regarding jumper settings, specific fixes, or other information to complete the upgrade.

Upgrading the BIOS

Follow the instructions in the readme file that came with the BIOS upgrade. When the update completes, remove the bootable media from which you performed the upgrade.

NOTES

Do not power down the system during the BIOS update process! The system will reset automatically when the BIOS update process is completed.

You may encounter a CMOS Checksum error or other problem after reboot. If this happens, shut down the system and boot it again. CMOS checksum errors require that you enter Setup, check your settings, save your settings, and exit Setup.

Clearing the Password

If the user or administrator password(s) is lost or forgotten, moving the password clear jumper into the “clear” position clears both passwords. The password clear jumper must be restored to its original position before a new password(s) can be set. The password clear jumper is located on jumper block J1H2.

1. Power down the system and disconnect the AC power.
2. Open the server chassis.
3. Move the jumper from the normal operation position, Password Clear Protect, at pins 2 and 3 to the Password Clear Erase position, covering pins 1 and 2 as indicated in the following diagram.

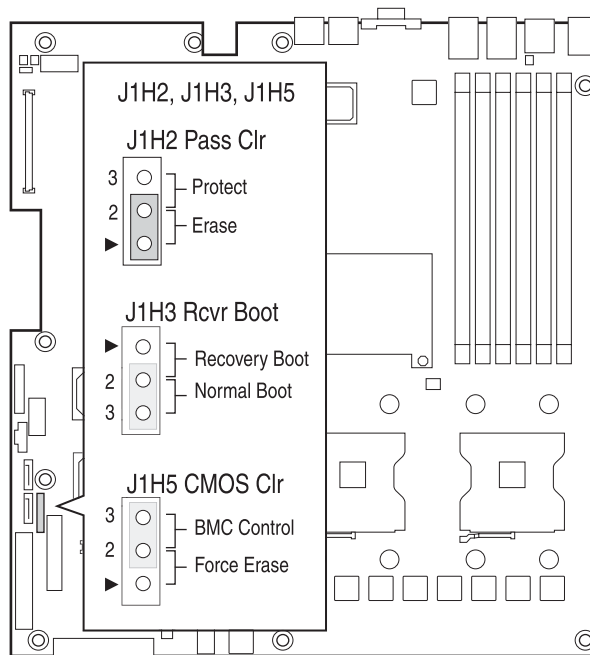

TP00947

Figure 14. Password Recovery Jumper

4. Reconnect the AC power, power up the system.
5. Power down the system and disconnect the AC power.
6. Return the Password Clear jumper to the Password Clear Protect position, covering pins 2 and 3.
7. Close the server chassis.
8. Reconnect the AC power and power up the server.

Clearing the CMOS

If you are not able to access the BIOS setup screens, the CMOS Clear jumper will need to be used to reset the configuration RAM. The CMOS Clear jumper is located on jumper block J1H5.

1. Power down the system and disconnect the AC power.
2. Open the server.
3. Move the jumper from the normal operation position, CMOS Clear by BMC, at pins 2 and 3 to the CMOS Clear Force Erase position, covering pins 1 and 2 as indicated in the following diagram.

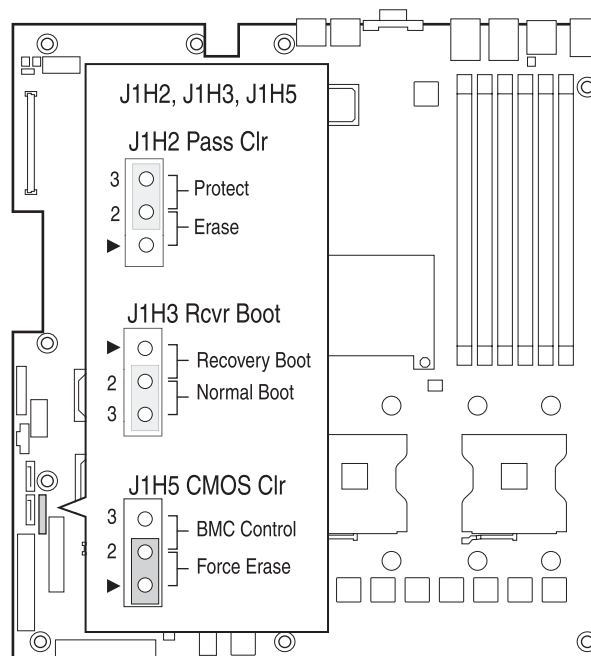

TP00948

Figure 15. CMOS Recovery Jumper

4. Reconnect the AC power, power up the system.
5. When the system begins beeping, power it down and disconnect the AC power.
6. Return the CMOS Clear jumper to the CMOS Clear by BMC location, covering pins 2 and 3.
7. Close the server chassis.
8. Reconnect the AC power and power up the system.

4 Troubleshooting

This chapter helps you identify and solve problems that might occur while you are using the system.

For any issue, first ensure you are using the latest firmware and files. Firmware upgrades include updates for BIOS, the baseboard management controller (BMC), and the hot-swap controller (HSC). See “[Additional Information and Software](#)” for a link to the software updates. In addition to the server firmware and files, also update any drivers used for components you have installed in your system, such as video drivers, network drivers, and SCSI drivers.

Intel provides a package called the “Platform Confidence Test” that may help with your diagnostics. See “[Additional Information and Software](#)” for a link to this software.

If you are unable to resolve your server problems on your own, see “Getting Help” for assistance.

Resetting the System

Before going through in-depth troubleshooting, attempt first to perform reset your system using one of the methods below.

To do this:	Press:
Soft boot reset to clear the system memory and reload the operating system.	<Ctrl+Alt+Del>
Clear system memory, restart POST, and reload the operating system.	Reset button
Cold boot reset. Turn the system power off and then on. This clears system memory, restarts POST, reloads the operating system, and halts power to all peripherals.	Power off/on

Problems following Initial System Installation

Problems that occur at initial system startup are usually caused by an incorrect installation or configuration. Hardware failure is a less frequent cause. If the problem you are experiencing is with a specific software application, see “[Problems with Newly Installed Application Software](#).”

First Steps Checklist

- Is AC power available at the wall outlet?
- Are the power supplies plugged in? Check the AC cable(s) on the back of the chassis and at the AC source.
- Are all cables correctly connected and secured?
- Are the processors fully seated in their sockets on the server board?
- Are all standoffs in the proper location and not touching any components, causing a potential short?
- Are all add-in PCI boards fully seated in their slots on the server board?
- Are all jumper settings on the server board correct?
- Are all jumper and switch settings on add-in boards and peripheral devices correct? To check these settings, refer to the manufacturer’s documentation that comes with them. If applicable, ensure that there are no conflicts—for example, two add-in boards sharing the same interrupt.
- Are all peripheral devices installed correctly?
- If the system has a hard disk drive, is it properly formatted or configured?
- Are all device drivers properly installed?
- Are the configuration settings made in Setup correct?
- Is the operating system properly loaded? Refer to the operating system documentation.
- Did you press the system power on/off switch on the front panel to turn the server on (power on light should be lit)?
- Is the system power cord properly connected to the system and plugged into a NEMA 5-15R outlet for 100-120 V or a NEMA 6-15R outlet for 200-240 V ?
- Are all integrated components from the tested components lists? Check the tested memory, and chassis lists, as well as the supported hardware and operating system list. See “[Additional Information and Software](#)” for links to the tested component lists.

Hardware Diagnostic Testing

This section provides a more detailed approach to identifying a hardware problem and locating its source.



CAUTION

Turn off devices before disconnecting cables: Before disconnecting any peripheral cables from the system, turn off the system and any external peripheral devices. Failure to do so can cause permanent damage to the system and/or the peripheral devices.

1. Turn off the system and all external peripheral devices. Disconnect each of device from the system, except for the keyboard and the video monitor.
2. Make sure the system power cord is plugged into a properly grounded AC outlet.
3. Make sure your video display monitor and keyboard are correctly connected to the system. Turn on the video monitor. Set its brightness and contrast controls to at least two thirds of their maximum ranges (see the documentation supplied with your video display monitor).
4. If the operating system normally loads from the hard disk drive, make sure there is no diskette in drive A and no CD-ROM disk in the CD-ROM drive.
5. If the power LED does light, attempt to boot from a floppy diskette or from a CD-ROM disk.
6. Turn on the system. If the power LED does not light, see [“Power Light Does Not Light.”](#)

Verifying Proper Operation of Key System Lights

As POST determines the system configuration, it tests for the presence of each mass storage device installed in the system. As each device is checked, its activity light should turn on briefly. Check for the following:

- Does the diskette drive activity light turn on briefly? If not, see [“Diskette Drive Activity Light Does Not Light.”](#)
- If system LEDs are illuminated, see [“LED Information”](#) for a description of the light and steps to take to correct the problem.

Confirming Loading of the Operating System

Once the system boots up, the operating system prompt appears on the screen. The prompt varies according to the operating system. If the operating system prompt does not appear, see [“No Characters Appear on Screen.”](#)

Specific Problems and Corrective Actions

This section provides possible solutions for these specific problems:

- Power light does not light.
- No characters appear on screen.
- Characters on the screen appear distorted or incorrect.
- System cooling fans do not rotate.
- Diskette drive activity light does not light.
- Hard disk drive activity light does not light.
- CD-ROM drive activity light does not light.
- There are problems with application software.
- The bootable CD-ROM is not detected.

Try the solutions below in the order given. If you cannot correct the problem, contact your service representative or authorized dealer for help.

Power Light Does Not Light

Check the following:

- Did you press the power-on button?
- Is the system operating normally? If so, the power LED might be defective or the cable from the front panel to the server board might be loose.
- Have you securely plugged the server AC power cord into the power supply?
- Will other items plugged into the same power outlet function correctly?
- Some ATX power supplies have a power switch on the back of the power supply, next to the fan. If your system has one, is it turned on?
- Remove all add-in cards and see if the system boots. If successful, add the cards back in one at a time with a reboot between each addition.
- Make sure the memory DIMMs comply with the system requirements.
- Make sure the memory DIMMs have been populated according to the system requirements.
- Remove the memory DIMMs and re-seat them.
- Make sure the processor(s) comply with the system requirements.
- Make sure the processor(s) have been populated according to the system requirements.
- Remove the processor(s) and re-seat them.
- Make sure the chassis standoffs are installed only below mounting holes. Misplaced standoffs can contact the pins on the bottom of the server board and cause a short.

No Characters Appear on Screen

Check the following:

- Is the keyboard functioning? Test it by turning the “Num Lock” function on and off to make sure the Num Lock light is functioning.
- Is the video monitor plugged in and turned on? If you are using a switch box, is it switched to the correct system?
- Are the brightness and contrast controls on the video monitor properly adjusted?
- Is the video monitor signal cable properly installed?
- Does this video monitor work correctly if plugged into a different system?
- Is the onboard video controller enabled in the BIOS?
- Remove all add-in cards and see if the video returns. If successful, add the cards back in one at a time with a reboot between each addition.
- Make sure the memory DIMMs comply with the system requirements.
- Make sure the memory DIMMs have been populated according to the system requirements.
- Remove the memory DIMMs and re-seat them.
- Make sure the processor(s) comply with the system requirements.
- Make sure the processor(s) have been populated according to the system requirements.
- Remove the processor(s) and re-seat them.

If you are using an add-in video controller board, do the following:

1. Verify that the video works using the onboard video controller.
2. Verify that the video controller board is fully seated in the server board connector.
3. Reboot the system for changes to take effect.
4. If there are still no characters on the screen after you reboot the system and POST emits a beep code, write down the beep code you hear. This information is useful for your service representative.
5. If you do not receive a beep code and characters do not appear, the video display monitor or video controller may have failed. Contact your service representative or authorized dealer for help.

Characters Are Distorted or Incorrect

Check the following:

- Are the brightness and contrast controls properly adjusted on the video monitor? See the manufacturer’s documentation.
- Are the video monitor’s signal and power cables properly installed?
- Does this video monitor work correctly if plugged into a different system?

System Cooling Fans Do Not Rotate Properly

If the system cooling fans are not operating properly, it is an indication of possible system component failure.

Check the following:

- Is the power-on light lit? If not, see [“Power Light Does Not Light”](#)
- If your system has LED lights for the fans, is one or more of these LEDs lit?
- Are any other front panel LEDs lit?
- Have any of the fan motors stopped? Use the server management subsystem to check the fan status.
- Have your fans speeded up in response to an overheating situation?
- Have your fans speeded up in response to a fan that has failed?
- Are the fan power connectors properly connected to the server board?
- Is the cable from the front panel board connected to the both the front panel board and to the server board?
- Are the power supply cables properly connected to the server board?
- Are there any shorted wires caused by pinched-cables or have power connector plugs been forced into power connector sockets the wrong way?

Diskette Drive Activity Light Does Not Light

Check the following:

- Are the diskette drive’s power and signal cables properly installed?
- Are all relevant switches and jumpers on the diskette drive set correctly?
- Is the diskette drive properly configured?
- Is the diskette drive activity light always on? If so, the signal cable may be plugged in incorrectly.

If you are using the onboard diskette controller, use the BIOS setup to make sure that “Onboard Floppy” is set to “Enabled.” If you are using an add-in diskette controller, make sure that “Onboard Floppy” is set to “Disabled.”

CD-ROM Drive or DVD-ROM Drive Activity Light Does Not Light

Check the following:

- Are the CD-ROM/DVD-ROM drive's power and signal cables properly installed?
- Are all relevant switches and jumpers on the drive set correctly?
- Is the drive properly configured?

Cannot Connect to a Server

- Make sure the network cable is securely attached to the correct connector at the system back panel.
- Try a different network cable.
- Make sure you are using the correct and the current drivers. See "[Additional Information and Software](#)" for a link to the current drivers.
- Make sure the driver is loaded and the protocols are bound.
- Make sure the hub port is configured for the same duplex mode as the network controller.
- Make sure the correct networking software is installed.
- If you are directly connecting two servers (without a hub), you will need a crossover cable.
- Check the network controller LEDs next to the NIC connectors.

Problems with Network

The server hangs when the drivers are loaded.

- Certain drivers may require interrupts that are not shared with other PCI drivers. For these drivers, it may be necessary to alter settings so that interrupts are not shared. See the documentation that came with your PCI card(s) for information on changing interrupts.

Diagnostics pass but the connection fails.

- Make sure the network cable is securely attached.
- Make sure you specify the correct frame type in your NET.CFG file.

The controller stopped working when an add-in adapter was installed.

- Make sure the cable is connected to the port from the onboard network controller.
- Make sure your BIOS is current. See "[Additional Information and Software](#)" for a link to the current version.
- Make sure the other adapter supports shared interrupts. Make sure your operating system supports shared interrupts.
- Try reseating the add-in adapter.

The add-in adapter stopped working without apparent cause.

- Try reseating the adapter first; then try a different slot if necessary.
- The network driver files may be corrupt or deleted. Delete and then reinstall the drivers.
- Run the diagnostics.

System Boots when Installing PCI Card

System Server Management features require full-time “standby” power. This means some parts of the system have power going to them whenever the power cord is plugged in, even if you have turned the system power off with the power button on the front panel. If you install a PCI card with the AC power cord plugged in, a signal may be sent to the command the system to boot. Before installing a PCI card, you should always:

- Turn off the server power by using the power button on the front of the system.
- Unplug the AC power cord(s) from the server.

Problems with Newly Installed Application Software

Problems that occur when you run new application software are usually related to the software, not the server hardware. Faulty equipment is unlikely, especially if other software runs correctly.

Check the following:

- Make sure the system meets the minimum hardware requirements for the software. See the software documentation.
- Make sure the software is properly installed and configured for the system. See the software documentation.
- Use only an authorized copy. Unauthorized copies often do not work.
- If you are running the software from a diskette, CD-ROM or DVD-ROM, try a different diskette.
- Make sure the correct device drivers installed.

If the problems persist, contact the software vendor’s customer service representative.

Problems with Application Software that Ran Correctly Earlier

Problems that occur after the system hardware and software have been running correctly sometimes indicate equipment failure. However, they can also be caused by file corruption or changes to the software configuration.

Check the following:

- If you are running the software from a diskette, CD-ROM or DVD-ROM, try a different diskette.
- Check your system for a virus infection.
- Uninstall and reinstall the software. Make sure all necessary files are installed.
- If the problems are intermittent, there may be a loose cable, dirt in the keyboard (if keyboard input is incorrect), a marginal power supply, or other random component failures.

- ❑ If you suspect that a transient voltage spike, power outage, or brownout might have occurred, reload the software and try running it again. Symptoms of voltage spikes include a flickering video display, unexpected system reboots, and the system not responding to user commands.

 **NOTE**

Random errors in data files: If you are getting random errors in your data files, they may be getting corrupted by voltage spikes on your power line. If you are experiencing any of the above symptoms that might indicate voltage spikes on the power line, you may want to install a surge suppressor between the power outlet and the system power cord.

Devices are not Recognized under Device Manager (Windows* Operating System)

The Windows* operating systems do not include all of the drivers for the Intel® chipsets, onboard NICs, and other components. See “[Additional Information and Software](#)” for a link to the current drivers and chipset files.

Hard Drive(s) are not Recognized

Check the following:

- ❑ Make sure the drive is not disabled in BIOS Setup.
- ❑ Make sure the drive is connected correctly and that is plugged into the power supply.
- ❑ Make sure the drive is compatible. See “[Additional Information and Software](#)” for a link to the tested drives.
- ❑ Make sure you have not exceeded the power budget for the server. See “[Additional Information and Software](#)” for a link to software to check your power budget.
- ❑ If using SCSI drives, verify that each SCSI ID number is unique on the SCSI bus. See your drive documentation for details on setting the SCSI ID for your drives.
- ❑ If using ATA drives, verify that the master/slave settings are set correctly. See your drive documentation for details on setting the master/slave settings.
- ❑ If using a RAID configuration with SCSI or SATA drives, make sure the RAID card is installed correctly.

Bootable CD-ROM Is Not Detected

Check the following:

- ❑ Make sure the BIOS is configured to allow the CD-ROM to be the first bootable device.

LED Information

The Intel® Server Board SE7320VP2 includes LEDs that can aid in troubleshooting your system. A table of these LEDs with a description of their use is listed below.

Table 9. Keyboard Commands

LED Name	Function	Location	Color	Correction
ID	Aid in server identification from the back panel	Control panel and board rear left corner	Blue	Press ID LED button or user Server Management software to turn off the LED.
System fault	Visible fault warning	Control panel and board rear left corner	Green or Amber	On = No Fault Green Blink = degraded Amber = critical error or non-recoverable Amber blink = non-critical
ATA drive activity	Control panel	Control panel and board left side	Green	Blinking = Activity. No action required.
Memory fault 1–6	Identify failing memory module	DIMM end rear of board	Amber	On = Fault
POST code 1–4 (LSB, bit1, bit2, MSB)	Display boot 80 POST code	Left rear of board	Each LED can be Off, Green, Amber, Red	See the POST code table in the <i>Intel® Server Board SE7530VP2 Technical Product Specification</i>
5v Standby	Identify 5v standby power on state	Front left board	Amber	On = 5v standby power on
Power LED	Identify the power state of the system	Control Panel	Green	Off = Power is off (off or S5) On = Power on or S0 Slow Blink = Low power state (S1 – S3)

Regulatory and Compliance Information

Product Regulatory Compliance

Product Safety Compliance

The Server Board SE7320VP2-E complies with the following safety requirements:

- UL60950 – CSA 60950(USA / Canada)
- EN60950 (Europe)
- IEC60950 (International)
- CB Certificate & Report, IEC60950 (report to include all country national deviations)
- GOST R 50377-92 – Listed on one System License (Russia)
- Belarus License – Listed on System License (Belarus)
- CE - Low Voltage Directive 73/23/EEE (Europe)
- IRAM Certification (Argentina)

Product EMC Compliance – Class A Compliance

NOTE

Legally the product is required to comply with Class A emission requirements as it is intended for a commercial type market place. Intel targets 10db margin to Class A Limits.

The Server Board SE7320VP2 has been tested and verified to comply with the following electromagnetic compatibility (EMC) regulations when installed a compatible Intel® host system. For information on compatible host system(s) refer to Intel's Server Builder Web site or contact your local Intel representative.

- FCC /ICES-003 - Emissions (USA/Canada) Verification
- CISPR 22 – Emissions (International)
- EN55022 - Emissions (Europe)
- EN55024 - Immunity (Europe)
- CE – EMC Directive 89/336/EEC (Europe)
- AS/NZS 3548 Emissions (Australia / New Zealand)
- BSMI CNS13438 Emissions (Taiwan)
- GOST R 29216-91 Emissions - Listed on one System License (Russia)
- GOST R 50628-95 Immunity –Listed on one System License (Russia)
- Belarus License – Listed on one System License (Belarus)
- RRL MIC Notice No. 1997-41 (EMC) & 1997-42 (EMI) (Korea)





Certifications / Registrations / Declarations

- UL Certification (US/Canada)
- CE Declaration of Conformity (CENELEC Europe)
- FCC/ICES-003 Class A Attestation (USA/Canada)
- C-Tick Declaration of Conformity (Australia)
- MED Declaration of Conformity (New Zealand)
- BSMI Certification (Taiwan)
- GOST – Listed on one System License (Russia)
- Belarus – Listed on one System License (Belarus)
- RRL Certification (Korea)
- Ecology Declaration (International)

Product Regulatory Compliance Markings

This product is marked with the following Product Certification Markings:

Table 10. Product Certification Markings

Regulatory Compliance	Country	Marking
UL Mark	USA/Canada	
CE Mark	Europe	
FCC Marking (Class A)	USA	This device complies with Part 15 of the FCC Rules. Operation of this device is subject to the following two conditions: (1) This device may not cause harmful interference, and (2) This device must accept any interference received, including interference that may cause undesired operation. Manufactured by Intel Corporation
EMC Marking (Class A)	Canada	CANADA ICES-003 CLASS A CANADA NMB-003 CLASSE A
BSMI Marking (Class A)	Taiwan	 <div style="border: 1px solid black; padding: 5px; width: fit-content;">警告使用者： 這是甲類的資訊產品，在居住的環境中使用時，可能會造成射頻干擾，在這種情況下，使用者會被要求採取某些適當的對策</div>
RRL MIC Mark	Korea	

Electromagnetic Compatibility Notices

FCC (USA)

This device complies with Part 15 of the FCC Rules. Operation is subject to the following two conditions: (1) this device may not cause harmful interference, and (2) this device must accept any interference received, including interference that may cause undesired operation.

For questions related to the EMC performance of this product, contact:

Intel Corporation
5200 N.E. Elam Young Parkway
Hillsboro, OR 97124-6497
1-800-628-8686

This equipment has been tested and found to comply with the limits for a Class A digital device, pursuant to Part 15 of the FCC Rules. These limits are designed to provide reasonable protection against harmful interference in a residential installation. This equipment generates, uses, and can radiate radio frequency energy and, if not installed and used in accordance with the instructions, may cause harmful interference to radio communications. However, there is no guarantee that interference will not occur in a particular installation. If this equipment does cause harmful interference to radio or television reception, which can be determined by turning the equipment off and on, the user is encouraged to try to correct the interference by one or more of the following measures:

- Reorient or relocate the receiving antenna.
- Increase the separation between the equipment and the receiver.
- Connect the equipment to an outlet on a circuit other than the one to which the receiver is connected.
- Consult the dealer or an experienced radio/TV technician for help.

Any changes or modifications not expressly approved by the grantee of this device could void the user's authority to operate the equipment. The customer is responsible for ensuring compliance of the modified product.

Only peripherals (computer input/output devices, terminals, printers, etc.) that comply with FCC Class A or B limits may be attached to this computer product. Operation with noncompliant peripherals is likely to result in interference to radio and TV reception.

All cables used to connect to peripherals must be shielded and grounded. Operation with cables, connected to peripherals, that are not shielded and grounded may result in interference to radio and TV reception.

Industry Canada (ICES-003)

Cet appareil numérique respecte les limites bruits radioélectriques applicables aux appareils numériques de Classe A prescrites dans la norme sur le matériel brouilleur: “Appareils Numériques”, NMB-003 édictée par le Ministre Canadien des Communications.

This digital apparatus does not exceed the Class A limits for radio noise emissions from digital apparatus set out in the interference-causing equipment standard entitled: “Digital Apparatus,” ICES-003 of the Canadian Department of Communications.

Europe (CE Declaration of Conformity)

This product has been tested in accordance too, and complies with the Low Voltage Directive (73/23/EEC) and EMC Directive (89/336/EEC). The product has been marked with the CE Mark to illustrate its compliance.

Taiwan Declaration of Conformity (BSMI)

警告使用者：
這是甲類的資訊產品，在居住的環境中使用時，
可能會造成射頻干擾，在這種情況下，使用者會
被要求採取某些適當的對策

The BSMI Certification Marking and EMC warning is located on the outside rear area of the product.

Korean Compliance (RRL)



1. 기기의 명칭(모델명) :
2. 인증번호 :
3. 인증받은 자의 상호 :
4. 제조년월일 :
5. 제조자/제조국가 :

English translation of the notice above:

1. Type of Equipment (Model Name): On License and Product
2. Certification No.: On RRL certificate. Obtain certificate from local Intel representative
3. Name of Certification Recipient: Intel Corporation
4. Date of Manufacturer: Refer to date code on product
5. Manufacturer/Nation: Intel Corporation/Refer to country of origin marked on product

Getting Help

World Wide Web

<http://support.intel.com/support/motherboards/server/SE7320VP2>

Telephone

All calls are billed US \$25.00 per incident, levied in local currency at the applicable credit card exchange rate plus applicable taxes. (Intel reserves the right to change the pricing for telephone support at any time without notice).

Before calling, fill out an “[Intel® Server Issue Report Form](#).” A sample form is provided on the following pages. However, for the fastest service, please submit your form via the Internet.

Table 11. Customer Support Telephone Numbers

In U.S. and Canada		1-800-404-2284	
In Europe			
UK	0870 6072439	Finland	9 693 79297
France	01 41 918529	Denmark	38 487077
Germany	069 9509 6099	Norway	23 1620 50
Italy	02 696 33276	Sweden	08 445 1251
Spain	91 377 8166	Holland	020 487 4562
Belgium	02 714 3182		
In Asia-Pacific region			
Australia	1800 649931	Indonesia	803 65 7249
Hong Kong	852 2 844 4456	Malaysia	1 800 80 1390
Korea	822 767 2595	New Zealand	0800 444 365
China	800 820 1100 (toll-free) 8 621 33104691 (not toll-free)	Pakistan	632 63684 15 (IDD via Philippines)
Singapore	65 6213-1311	Philippines	1 800 1 651 0117
India	0006517 2 68303634 (manual toll-free. From India, you need an IDD-equipped telephone)	Thailand	1 800 631 0003
Taiwan	2 2545-1640	Vietnam	632 6368416 (IDD via Philippines)
		Myanmar	63 2 636 9796 (via Philippines)
		Cambodia	63 2 636 9797 (via Philippines)
In Japan			
0120 868686 (Domestic)		81 298 47 0800 (outside country)	

Getting Help

In Latin America

Brazil	001-916 377 0180	Ecuador (Andimate)	Contact AT&T USA at 1 999 119. Once connected, dial 800 843 4481
Mexico	Contact AT&T USA at 001 800 462 628 4240. Once connected, dial 800 843 4481	Ecuador (Pacifictel)	Contact AT&T USA at 1 800 225 528. Once connected, dial 800 843 4481
Colombia	Contact AT&T USA at 01 800 911 0010. Once connected, dial 800 843 4481	Guatemala	Contact AT&T USA at 99 99 190. Once connected, dial 800 843 4481
Costa Rica	Contact AT&T USA at 0 800 0 114 114. Once connected, dial 800 843 4481	Venezuela	Contact AT&T USA at 0 800 2255 288. Once connected, dial 800 843 4481
Panama	Contact AT&T USA at 00 800 001 0109. Once connected, dial 800 843 4481	Argentina	Contact AT&T USA at 0-800 222 1288. Once connected, dial 800 843 4481
Chile (Easter Island)	Contact AT&T USA at 800 800 311. Once connected, dial 800 843 4481	Paraguay	001 916 377 0114
Chile (Mainland and Juan)	Contact AT&T USA at 800 225 288. Once connected, dial 800 843 4481	Peru	001 916 377 0114
Miami	1 800 621 8423	Uruguay	001 916 377 0114

For an updated support contact list, see <http://www.intel.com/support/9089.htm/>

Intel® Server Issue Report Form

 **NOTE**

An on-line / automatic submission version of this form is available at <http://support.intel.com/support/motherboards/server/SE7320VP2>.

For the fastest service, please submit your form via the Internet.

Date Submitted: _____

Company Name: _____

Contact Name: _____

Email Address: _____

Intel Server Product: _____

Priority (Critical, Hot, High, Low): _____

Brief Problem Description. Provide a brief description below. See the last page for space to include a detailed problem description.

Board / Chassis Information

Baseboard Revision – PBA#:	DIMM Configuration
Baseboard Serial Number:	DIMM1A MB:
CPU1 Speed/Stepping/Spec:	DIMM1A Vendor / part number:
CPU2 Speed/Stepping/Spec:	DIMM1B MB:
System BIOS Version:	DIMM1B Vendor / part number:
HSC Firmware Version:	DIMM2A MB:
Chassis Model	DIMM2A Vendor / part number:
<input type="checkbox"/> Intel Server Chassis SR2400r	DIMM2B MB:
<input type="checkbox"/> Intel Server Platform SR1435VP2	DIMM2B Vendor / part number:
<input type="checkbox"/> Other (Vendor / Model):	DIMM3A MB
	DIMM3B Vendor / part number

Issue Report Form

Operating System Information

Operating System _____

Version _____

Service Pack _____

Peripheral Information

Check each box below that is used, and provide the requested information

Peripheral	Card or Peripheral Description	Driver Revision	IRQ #	I/O Base Address	FW Rev#
Low-profile Riser					
<input type="checkbox"/>	Top slot				
<input type="checkbox"/>	Center slot				
<input type="checkbox"/>	Bottom slot				
Full-height Riser					
<input type="checkbox"/>	Top slot				
<input type="checkbox"/>	Center slot				
<input type="checkbox"/>	Bottom slot				
Video					
<input type="checkbox"/>	On-Board Video				
<input type="checkbox"/>	Add-in Video				
NIC					
<input type="checkbox"/>	On-Board NIC1 (10/100/1000 Mb)				
<input type="checkbox"/>	On-Board NIC2 (10/100/1000 Mb)				

Hard Drive Information:

ATA # of drives installed: _____
Make/Model/Firmware Revision _____

SATA # of drives installed: _____
Make/Model/Firmware Revision _____
Hot-swap: ____ Fixed: ____

Management Information:

Essentials Server Management (on-board)

Control Panel Information:

Standard Control Panel
