

# Intel® Server System H2000JF Family

## *Technical Product Specification*

*Intel order number: G39462-011*



**Revision 2.0**

**September, 2013**

**Enterprise Platforms and Services Division**

## *Revision History*

Date	Revision Number	Modifications
January, 2012	1.0	Initial release.
February, 2012	1.1	Added environmental data.
March, 2012	1.2	Updated environmental specifications.
May, 2012	1.3	<ul style="list-style-type: none"> <li>▪ Updated environmental specifications with ASHRAE specification.</li> <li>▪ Updated Processor TDP to conditional support 135W.</li> <li>▪ Added new bridge board for 6G SAS support.</li> <li>▪ Added riser support for non-transparent bridge.</li> </ul>
July, 2012	1.4	<ul style="list-style-type: none"> <li>▪ Updated safety notice to rail kit installation.</li> <li>▪ Updated InfiniBand* usage recommendation.</li> </ul>
August, 2012	1.5	<ul style="list-style-type: none"> <li>▪ Corrected typo in USB device beep in POST.</li> <li>▪ Added new 6G SAS module solution.</li> <li>▪ Updated power redundant scheme.</li> </ul>
October, 2012	1.6	<ul style="list-style-type: none"> <li>▪ Updated link to Rail specification.</li> <li>▪ Updated system specification.</li> </ul>
November, 2012	1.7	<ul style="list-style-type: none"> <li>▪ Updated description of double width add-in card.</li> <li>▪ Updated warning message on PSU configuration.</li> </ul>
January, 2013	1.8	Updated E5-2600V2 support information.
June, 2013	1.9	Updated Rail installation note. Updated power working mode.
September, 2013	2.0	Updated POST LED decode table, Video POST decode table, and POST error beep code.

## Disclaimers

INFORMATION IN THIS DOCUMENT IS PROVIDED IN CONNECTION WITH INTEL PRODUCTS. NO LICENSE, EXPRESS OR IMPLIED, BY ESTOPPEL OR OTHERWISE, TO ANY INTELLECTUAL PROPERTY RIGHTS IS GRANTED BY THIS DOCUMENT. EXCEPT AS PROVIDED IN INTEL'S TERMS AND CONDITIONS OF SALE FOR SUCH PRODUCTS, INTEL ASSUMES NO LIABILITY WHATSOEVER AND INTEL DISCLAIMS ANY EXPRESS OR IMPLIED WARRANTY, RELATING TO SALE AND/OR USE OF INTEL PRODUCTS INCLUDING LIABILITY OR WARRANTIES RELATING TO FITNESS FOR A PARTICULAR PURPOSE, MERCHANTABILITY, OR INFRINGEMENT OF ANY PATENT, COPYRIGHT OR OTHER INTELLECTUAL PROPERTY RIGHT.

A "Mission Critical Application" is any application in which failure of the Intel Product could result, directly or indirectly, in personal injury or death. SHOULD YOU PURCHASE OR USE INTEL'S PRODUCTS FOR ANY SUCH MISSION CRITICAL APPLICATION, YOU SHALL INDEMNIFY AND HOLD INTEL AND ITS SUBSIDIARIES, SUBCONTRACTORS AND AFFILIATES, AND THE DIRECTORS, OFFICERS, AND EMPLOYEES OF EACH, HARMLESS AGAINST ALL CLAIMS COSTS, DAMAGES, AND EXPENSES AND REASONABLE ATTORNEYS' FEES ARISING OUT OF, DIRECTLY OR INDIRECTLY, ANY CLAIM OF PRODUCT LIABILITY, PERSONAL INJURY, OR DEATH ARISING IN ANY WAY OUT OF SUCH MISSION CRITICAL APPLICATION, WHETHER OR NOT INTEL OR ITS SUBCONTRACTOR WAS NEGLIGENT IN THE DESIGN, MANUFACTURE, OR WARNING OF THE INTEL PRODUCT OR ANY OF ITS PARTS.

Intel may make changes to specifications and product descriptions at any time, without notice. Designers must not rely on the absence or characteristics of any features or instructions marked "reserved" or "undefined". Intel reserves these for future definition and shall have no responsibility whatsoever for conflicts or incompatibilities arising from future changes to them. The information here is subject to change without notice. Do not finalize a design with this information.

The products described in this document may contain design defects or errors known as errata which may cause the product to deviate from published specifications. Current characterized errata are available on request.

Contact your local Intel sales office or your distributor to obtain the latest specifications and before placing your product order.

Copies of documents which have an order number and are referenced in this document, or other Intel literature, may be obtained by calling 1-800-548-4725, or go to: <http://www.intel.com/design/literature>.

## *Table of Contents*

<b>1. Introduction .....</b>	<b>1</b>
1.1 Chapter Outline.....	1
1.2 Server Board Use Disclaimer .....	2
<b>2. Product Overview.....</b>	<b>3</b>
2.1 System Views .....	5
2.2 System Dimensions .....	5
2.3 System Level Environmental Limits .....	6
2.3.1 High Temperature Ambience (HTA) Support.....	7
2.3.2 Set Throttling Mode .....	11
2.3.3 Altitude.....	11
2.3.4 Set Fan Profile .....	11
2.3.5 Fan PWM Offset .....	11
2.3.6 Quiet Fan Idle Mode .....	11
2.3.7 Thermal Sensor Input for Fan Speed Control.....	12
2.4 System Parts .....	13
2.5 Hard Drive and Peripheral Bays .....	14
2.6 Server Board Overview.....	14
2.7 Front Bezel Support.....	17
2.8 Rack and Cabinet Mounting Options .....	18
<b>3. Power Subsystem .....</b>	<b>19</b>
3.1 Mechanical Overview.....	19
3.1.1 AC Power Supply Unit Dimension Overview .....	19
3.1.2 AC Power Supply Unit General Data.....	20
3.1.3 AC Input Connector .....	20
3.1.4 AC Power Cord Specification Requirements .....	20
3.1.5 Power Supply Unit DC Output Connector.....	20
3.1.6 Handle Retention .....	21
3.1.7 LED Marking and Identification.....	21
3.1.8 Power Cage with Power Distribution Board.....	22
3.1.9 Power Cage Output Pin Assignment .....	22
3.2 AC Input Specification .....	24
3.2.1 Input Voltage and Frequency.....	24
3.2.2 AC Input Power Factor .....	24
3.2.3 Efficiency .....	24
3.2.4 AC Line Fuse .....	25
3.2.5 AC Line Inrush .....	25
3.2.6 AC Line Dropout/Holdup.....	25
3.2.7 AC Line Fast Transient (EFT) Specification .....	26
3.2.8 Hot Plug.....	26

3.2.9	Susceptibility Requirements .....	26
3.2.10	Electrostatic Discharge Susceptibility .....	26
3.2.11	Fast Transient/Burst .....	26
3.2.12	Radiated Immunity .....	26
3.2.13	Surge Immunity.....	26
3.2.14	AC Line Transient Specification.....	27
3.2.15	Power Recovery .....	27
3.2.16	Voltage Interruptions.....	27
3.2.17	AC Line Isolation.....	27
3.2.18	AC Power Inlet.....	28
3.3	DC Output Specification .....	28
3.3.1	Output Power/Currents .....	28
3.3.2	Standby Output.....	28
3.3.3	Voltage Regulation .....	29
3.3.4	Dynamic Loading .....	29
3.3.5	Capacitive Loading .....	29
3.3.6	Ripple/Noise .....	29
3.3.7	Grounding .....	30
3.3.8	Closed Loop Stability .....	30
3.3.9	Residual Voltage Immunity in Standby Mode .....	30
3.3.10	Common Mode Noise .....	30
3.3.11	Soft Starting .....	30
3.3.12	Zero Load Stability Requirement .....	31
3.3.13	Hot Swap Requirement.....	31
3.3.14	Forced Load Sharing .....	31
3.3.15	Timing Requirement .....	31
3.4	Power Supply Cold Redundancy Support .....	32
3.4.1	1200W CRPS Cold Redundancy.....	33
3.4.2	1600W CRPS Cold Redundancy.....	33
3.5	Control And Indicator Functions .....	33
3.5.1	PSON# Input Signal.....	34
3.5.2	PWOK (Power Good) Output Signal.....	34
3.5.3	SMBAlert# Signal.....	34
3.6	Protection Circuits.....	35
3.6.1	Current Limit (OCP) .....	35
3.6.2	Over Voltage Protection (OVP).....	35
3.6.3	Over Thermal Protection (OTP).....	36
3.7	PMBus* .....	36
3.7.1	PSU Address Lines A0 .....	36
3.7.2	Accuracy .....	37
3.8	Power Management Policy .....	37

<b>4. Cooling Subsystem</b>	<b>39</b>
4.1 Processor Heatsink	39
4.2 Node Cooling Fans	40
4.3 Power Supply Fan	41
4.4 Air Duct Module	41
4.5 Drive Bay Population Requirement	42
<b>5. System Boards in the Node Tray</b>	<b>43</b>
5.1 Node Docking Board	43
5.1.1 Overview of Node Docking Board	43
5.1.2 Pin-out Definition on Node Docking Board	44
5.2 Bridge Board	45
5.2.1 Overview of Bridge Board	45
5.2.2 Pin-out Definition on Bridge Board	47
5.3 6Gbs SAS Support Option 1	48
5.3.1 Overview of Bridge Board	48
5.3.2 Pin-out Definition on SAS 6Gbs Bridge Board	50
5.4 6Gbs SAS Support Option 2	51
5.4.1 Bridge Board	51
5.4.2 Riser Card	53
5.4.3 SAS Controller Module	55
<b>6. Hard Disk Drive Support</b>	<b>57</b>
6.1 Hard Disk Drive Bays Scheme	57
6.2 Hard Drive Carrier	57
6.3 Hot-Swap Hard Drive Support	58
6.3.1 Backplane Feature Set	59
6.3.2 Backplane Block Diagram	60
6.3.3 3.5" Hot Swap Backplane Connector Scheme	60
6.3.4 2.5" Hot Swap Backplane Connector Scheme	61
6.3.5 Backplane LED Support	63
6.3.6 Backplane Connector Definition	63
<b>7. Front Panel Control and Indicators</b>	<b>67</b>
7.1 Control Panel Button	68
7.2 Control Panel LED Indicators	68
7.2.1 Power/Sleep LED	69
7.2.2 System Status LED	69
7.2.3 System Status LED – BMC Initialization	70
<b>8. Configuration Jumpers</b>	<b>71</b>
8.1 Force Integrated BMC Update (J6B1)	72
8.2 Force ME Update (J1E2)	73
8.3 Password Clear (J1E3)	73
8.4 BIOS Recovery Mode (J1E1)	74

8.5	Reset BIOS Settings (J1D5) .....	75
<b>9.</b>	<b>PCI Express* Riser Card and Assembly .....</b>	<b>77</b>
9.1	PCI Express* Riser for Slot 1 .....	77
9.1.1	Overview of PCI-Express* Riser .....	77
9.1.2	Pin-out Definition on Slot 1 Riser .....	77
9.2	PCI Express* Riser with IOM Carrier for Slot 2 (Optional) .....	82
9.2.1	Overview of PCI-E* Riser with IOM Carrier .....	82
9.2.2	Pin-out Definition on Slot 2 Riser and IOM Carrier .....	83
	<b>Appendix A: Integration and Usage Tips .....</b>	<b>89</b>
	<b>Appendix B: POST Code LED Decoder .....</b>	<b>90</b>
	<b>Appendix C: Video POST Code Errors .....</b>	<b>95</b>
	<b>Glossary .....</b>	<b>102</b>
	<b>Reference Documents .....</b>	<b>105</b>

## *List of Figures*

Figure 1. System Overview (Air Duct Removed) .....	5
Figure 2. Compute Node Scheme (Rear View) .....	5
Figure 3. Fan Control Model .....	13
Figure 4. Major System Parts .....	13
Figure 5. Intel® Server System H2312JF Drive Bay Overview.....	14
Figure 6. Intel® Server System H2216JF Drive Bay Overview.....	14
Figure 7. Intel® Server Board S2600JFQ/S2600JFF .....	15
Figure 8. Intel® Server Board S2600JF Components .....	16
Figure 9. Back Panel Feature Overview .....	16
Figure 10. Light-Guided Diagnostic LED Locations(Block A) .....	17
Figure 11. System Bezel Front View.....	17
Figure 12. AC Power Supply Unit Dimension Overview .....	19
Figure 13. Power Cage Overview .....	22
Figure 14. Power Distribution Board .....	23
Figure 15. AC Power Cord Specification .....	28
Figure 16. Turn On/Off Timing (Power Supply Signals).....	32
Figure 17. Power Supply Device Address .....	36
Figure 18. PMBus* Monitoring Accuracy .....	37
Figure 19. Processor Heatsink Overview.....	39
Figure 20. Node Fan Set and Power/Control Connection.....	41
Figure 21. Compute Node Air Duct (Top View) .....	42
Figure 22. Compute Node Tray Overview .....	43
Figure 23. Node Docking Board.....	43
Figure 24. Bridge Board Overview .....	45
Figure 25. Connectors on Bridge Board .....	46
Figure 26. SAS 6Gbs Bridge Board Overview .....	49
Figure 27. Connectors and Components on Spare Bridge Board .....	50
Figure 28. Overview of the Bridge Board.....	52
Figure 29. Connectors on Bridge Board .....	52
Figure 30. Overview of the Riser Card.....	53
Figure 31. SAS Controller Module Overview .....	56
Figure 32. HDD Scheme for H2312JF .....	57
Figure 33. HDD Scheme for H2216JF .....	57
Figure 34. 3.5-inch HDD Assembly Overview.....	58
Figure 35. 2.5-inch HDD Assembly Overview.....	58
Figure 36. Passive Backplane Block Diagram (for One Node) .....	60
Figure 37. 3.5" Backplane Component and Connectors (Front View) .....	60
Figure 38. 3.5" Backplane Component and Connectors (Back View).....	61
Figure 39. 2.5" Backplane Component and Connectors (Front View) .....	62



Figure 40. 2.5" Backplane Component and Connectors (Back View)..... 62

Figure 41. Hard Drive Carrier LED..... 63

Figure 42. Front Control Panel..... 67

Figure 43. Jumper Locations and Functions ..... 71

Figure 44. PCI Express\* Riser for Riser Slot 1 ..... 77

Figure 45. PCI Express\* Riser with Bracket for Riser Slot 2..... 82

Figure 46. IOM Carrier ..... 82

Figure 47. Diagnostic LED Location ..... 90

## *List of Tables*

Table 1. System Feature Set .....	3
Table 2. System SKU Matrix.....	4
Table 3. Chassis Dimension (SKU: H2312JF).....	5
Table 4. Chassis Dimension (SKU: H2216JF).....	6
Table 5. System Environmental Limits Summary .....	6
Table 6. Ambient Temperature versus System Configuration .....	9
Table 7. Specification Data for AC Power Supply Unit .....	20
Table 8. AC Power Cord Specification.....	20
Table 9. DC Output Power Connector .....	20
Table 10. Power Supply Status LED.....	21
Table 11. Pin Assignment of Power Output Connector .....	23
Table 12. Pin Assignment of Control Signal Connector .....	23
Table 13. AC Input Rating.....	24
Table 14. Typical Power Factor .....	24
Table 15. Platinum Efficiency Requirement .....	25
Table 16. AC Power Holdup Requirement.....	25
Table 17. Performance Criteria .....	26
Table 18. AC Line Sag Transient Performance .....	27
Table 19. AC Line Surge Transient Performance .....	27
Table 20. Load Ratings for Single Power Supply Unit .....	28
Table 21. Voltage Regulation Limits .....	29
Table 22. Transient Load Requirements.....	29
Table 23. Capacitive Loading Conditions .....	29
Table 24. Ripple and Noise.....	30
Table 25. Timing Requirement.....	31
Table 26. 1200W CRPS Cold Redundancy Threshold .....	33
Table 27. 1600W CRPS Cold Redundancy Threshold .....	33
Table 28. PSON# Signal Characteristics .....	34
Table 29. PWOK Signal Characteristics .....	34
Table 30. SMBAlert# Signal Characteristics .....	35
Table 31. Over Current Protection .....	35
Table 32. Over Voltage Protection (OVP) Limits .....	36
Table 33. PSU Addressing.....	37
Table 34. PMBus* Accuracy .....	37
Table 35. Power Management Policy .....	38
Table 36. 8-Pin Connector Pin-Out for Node Dual Rotor Fans .....	41
Table 37. Main Power Input Connector .....	44
Table 38. Fan Control Signal Connector.....	44
Table 39. Node Fan Connector.....	44

Table 40. Main Power Output Connector.....	45
Table 41. Card Edge Connector Pin-out.....	47
Table 42. AHCI SATA0 DOM Connector Pin-out.....	48
Table 43. USB 2.0 Type-A Connector Pin-out.....	48
Table 44. 5V_AUX Power Connector Pin-out.....	48
Table 45. Pin-out of Card Edge to Base Board.....	50
Table 46. Pin-out of Card Edge to Hot Swap Back Plane.....	51
Table 47. Pin-out of Mini SAS Connector.....	51
Table 48. Card Edge Pin-out of Bridge Board to SAS Controller.....	53
Table 49. Card Edge Pin-out of Riser Card to SAS Controller.....	53
Table 50. Card Edge Pin-out of Riser Card to PCIe Slot2 of Baseboard.....	54
Table 51. Hard Drive Carrier Status LED Functions.....	63
Table 52. Hard Drive Carrier Activity LED Functions.....	63
Table 53. Backplane Input Power Connector Pin-out.....	64
Table 54. 2-Blade Compute Node Power Connector Pin-out.....	64
Table 55. 2x40 Pin Connector Pin-out for Node Bridge Board.....	64
Table 56. Front Panel Connector Pin-out.....	65
Table 57. Power Supply Control Connector Pin-out.....	66
Table 58. Front Control Button Function.....	68
Table 59. Front LED Indicator Functions.....	68
Table 60. Power LED Operation.....	69
Table 61. System Status LED Operation.....	69
Table 62. Force Integrated BMC Update Jumper.....	72
Table 63. Force Integrated BMC Update Jumper.....	72
Table 64. Force ME Update Jumper.....	73
Table 65. BIOS Password Clear Jumper.....	74
Table 66. BIOS Recovery Mode Jumper.....	74
Table 67. Reset BIOS Jumper.....	75
Table 68. Riser Card Edge Pin-out.....	77
Table 69. PCI Express* Slot Pin-out on Riser Card.....	80
Table 70. Dedicated NIC Port LED Functionality.....	83
Table 71. Riser Card Edge Pin-out.....	83
Table 72. PCI Express* Slot Pin-out on Riser Card.....	85
Table 73. IO Module Slot on Carrier.....	87
Table 74. POST Code Diagnostic LED Location.....	90
Table 75. POST Progress Code LED Example.....	91
Table 76. Diagnostic LED POST Code Decoder.....	91
Table 77. POST Error Message and Message.....	95
Table 78. POST Error Beep Codes.....	100

<This page is intentionally left blank.>

# 1. Introduction

---

This Technical Product Specification (TPS) provides system specific information detailing the features, functionality, and high-level architecture of the Intel® Server System H2000JF family. You can also refer to the *Intel® Server Board S2600JF Family Technical Product Specification* to obtain greater detail of functionality and architecture of the server board integrated in this server system.

In addition, you can obtain design-level information for specific subsystems by ordering the External Product Specifications (EPS) or External Design Specifications (EDS) for a given subsystem. EPS and EDS documents are not publicly available. They are only made available under NDA with Intel and must be ordered through your local Intel representative. For a complete list of available documents, refer to the [Reference Documents](#) section at the end of this document.

The Intel® Server System H2000JF may contain design defects or errors known as errata which may cause the product to deviate from published specifications. Refer to the *Intel® Server Board S2600JF/Intel® Server System H2000JF Specification Update* for published errata.

## 1.1 Chapter Outline

This document is divided into the following chapters:

- Chapter 1 – Introduction
- Chapter 2 – Product Overview
- Chapter 3 – Power Subsystem
- Chapter 4 – Cooling Subsystem
- Chapter 5 – System Boards in the Node Tray
- Chapter 6 – Hard Disk Drive Support
- Chapter 7 – Front Panel Control and Indicators
- Chapter 8 – Configuration Jumpers
- Chapter 9 – PCI Express\* Riser Card and Assembly
- Appendix A – Integration and Usage Tips
- Appendix B – POST Code LED Decoder
- Appendix C – Video POST Code Errors
- Glossary
- Reference Documents

## 1.2 Server Board Use Disclaimer

Intel Corporation server boards support add-in peripherals and contain a number of high-density VLSI and power delivery components that need adequate airflow to cool. Intel ensures through its own chassis development and testing that when Intel server building blocks are used together, the fully integrated system will meet the intended thermal requirements of these components. It is the responsibility of the system integrator who chooses not to use Intel developed server building blocks to consult vendor datasheets and operating parameters to determine the amount of air flow required for their specific application and environmental conditions. Intel Corporation cannot be held responsible if components fail or the server board does not operate correctly when used outside any of their published operating or non-operating limits.

## 2. Product Overview

The Intel® Server System H2000JF family includes two major SKUs: H2312JF and H2216JF, which are rack mount 2U 4-node server systems, purpose-built for high-density and lowest total cost of ownership in dense computing applications, such as HPC and IPDC. The system is integrated with four units of Intel® Server Board S2600JF, and supports up to twelve 3.5" or sixteen 2.5" hot-swap SAS or SATA hard drives with Common Redundant Power Supply (CRPS) capability.

This chapter provides a high-level overview of the system features. The following chapters provide greater detail for each major system component or feature.

**Table 1. System Feature Set**

Feature	Description
Processor	Support Intel® Xeon® Processor E5-2600 and E5-2600V2 series processors: <ul style="list-style-type: none"> <li>Up to eight GT/s Intel® QuickPath Interconnect (Intel® QPI)</li> <li>LGA 2011 Socket R</li> <li>Thermal Design Power (TDP) up to 135W with conditional ambient temperature</li> </ul>
Memory	<ul style="list-style-type: none"> <li>Unbuffered DDR3 and registered DDR3 with ECC DIMMs</li> <li>Memory DDR3 data transfer rates of 800/1066/1333/1600/1867 MT/s</li> <li>Load Reduced DDR3 DIMM</li> <li>DDR3 standard I/O voltage of 1.5V (all speed) and DDR3 Low Voltage of 1.35V (1600MT/s or below)</li> </ul>
Chipset	Intel® C600 Platform Controller Hub (PCH) with support for optional Storage Upgrade Key
System Connectors/Headers	<p>External I/O connectors:</p> <ul style="list-style-type: none"> <li>DB-15 Video connectors</li> <li>Two RJ-45 Network Interface for 10/100/1000 LAN</li> <li>One stacked two port USB 2.0 (Port 0/1) connectors</li> <li>One dedicated 1GbE management port on rIOM carrier (optional)</li> <li>One InfiniBand* QDR QSFP port (Board SKU: <b>S2600JFQ</b>) or</li> <li>One InfiniBand* FDR QSFP port (Board SKU: <b>S2600JFF</b>)</li> </ul> <p>Internal connectors/headers:</p> <ul style="list-style-type: none"> <li>Bridge Slot to extend board I/O with common bridge board <ul style="list-style-type: none"> <li>SCU0 (Four SAS 3Gb/s ports) to backplane</li> <li>Front control panel signals</li> <li>One SATA (Port 0) 6Gb/s port for DOM</li> </ul> </li> <li>Bridge Slot to extend board I/O with spare bridge board <ul style="list-style-type: none"> <li>Mini SAS port (Four SAS 6Gb/s ports) from add-in RAID card to backplane</li> <li>Front control panel signals</li> </ul> </li> <li>One Type-A USB 2.0 connector (USB port 2)</li> <li>One 2x7pin header for system FAN module</li> <li>One DH-10 serial Port A connector</li> <li>One SATA 6Gb/s (Port 1)</li> <li>One 2x4 pin header for Intel® RMM4 Lite</li> <li>One 1x4 pin header for Storage Upgrade Key</li> </ul>
System Fan Support	Three sets of dual rotor fan for each node
Add-in Adapter Support	<p>Three PCIe Gen III x16 riser slots:</p> <ul style="list-style-type: none"> <li>Riser slot 1 supports PCIe Gen III x16 Riser with LP PCIe add-in card.</li> <li>Riser slot 2 supports PCIe Gen III x8 Riser (Intel® rIOM).</li> <li>Riser slot 3 cannot be used with bridge board covered.</li> </ul> <p>One Bridge Slot for board I/O expansion</p>
On-board Video	On-board Server Engines* LLC Pilot III Controller

Feature	Description
	<ul style="list-style-type: none"> <li>▪ Integrated 2D Video Controller</li> <li>▪ 128MB DDR2 Memory</li> </ul>
Hard Disk Drive Supported	12x 3.5-inch SATA/SAS HDD bays (SKU: <b>H2312JF</b> ) 16x 2.5-inch SATA/SAS HDD bays (SKU: <b>H2216JF</b> )
RAID Support	<ul style="list-style-type: none"> <li>▪ Intel® RSTe SW RAID 0/1/10/5 for SATA mode</li> <li>▪ LSI* SW RAID 0/1/10/5</li> </ul>
LAN	For each node: <ul style="list-style-type: none"> <li>▪ One Gigabit Ethernet device i350 connect to PCI-E x4 interfaces on the PCH, providing 2GbE ports for each node</li> <li>▪ One QSFP port from Mellanox* ConnectX-3* to support QDR/FDR Infiniband* based on board SKU</li> <li>▪ One dedicated 1GbE management port with RMM4 Lite installed</li> </ul>
System Power	1200w AC Common Redundant Power Supply (CRPS), 80 plus Platinum with PFC, supporting CRPS configuration. Chassis SKU: <b>H2312JFJR, H2216JFJR</b> 1600w AC Common Redundant Power Supply (CRPS), 80 plus Platinum with PFC, supporting CRPS configuration. Chassis SKU: <b>H2312JFKR, H2216JFKR</b>
Server Management	<ul style="list-style-type: none"> <li>▪ On-board ServerEngines* LLC Pilot III* Controller</li> <li>▪ Support for Intel® Remote Management Module 4 Lite solutions</li> <li>▪ Intel® Light-Guided Diagnostics on field replaceable units</li> <li>▪ Support for Intel® System Management Software</li> <li>▪ Support for Intel® Intelligent Power Node Manager (Need PMBus*-compliant power supply)</li> </ul>

Table 2. System SKU Matrix

Board SKU vs Chassis	3.5" HDD with 1200W CRPS	2.5" HDD with 1200W CRPS	3.5" HDD with 1600W CRPS	2.5" HDD with 1600W CRPS
S2600JF	H2312JFJR	H2216JFJR	H2312JFKR	H2216JFKR
S2600JFQ	H2312JFQJR	H2216JFQJR	H2312JFQKR	H2216JFQKR
S2600JFF	H2312JFFJR	H2216JFFJR	H2312JFFKR	H2216JFFKR

The Intel® Server System H2000JF family supports all Intel® Xeon® processor E5-2600 series with TDP 135W (8-core, 6-core) and below, or 80W (4-core) and below. You can find a full list of supported processors at the Intel® Support Website:

[http://www.intel.com/p/en\\_US/support/highlights/server/ss-h2000jf](http://www.intel.com/p/en_US/support/highlights/server/ss-h2000jf).



## 2.1 System Views

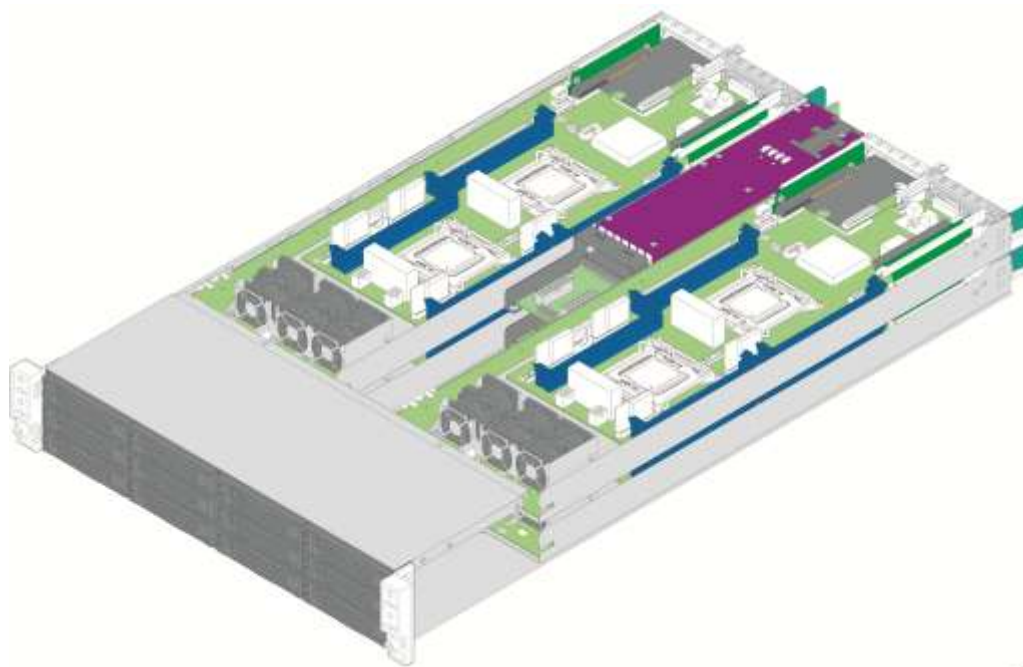

Figure 1. System Overview (Air Duct Removed)



Figure 2. Compute Node Scheme (Rear View)

**Caution:** Installing two Power Supply Units with different wattage ratings on a system is not supported. This does not provide Power Supply Redundancy and causes the system to log multiple errors.

## 2.2 System Dimensions

Table 3. Chassis Dimension (SKU: H2312JF)

Height	87.9mm	3.46"
Width	438mm	17.24"
Depth	771mm	30.35"
Weight	<b>kg</b>	<b>lbs</b>
Chassis – basic configured (2 PSU, 0 drives)	30	66.14
Chassis – fully configured (2 PSU, 12 drives)	38	83.78

**Table 4. Chassis Dimension (SKU: H2216JF)**

Height	87.9mm	3.46"
Width	438mm	17.24"
Depth	733mm	28.86"
Weight	<b>kg</b>	<b>lbs</b>
Chassis – basic configured (2 PSU, 0 drives)	29	63.93
Chassis – fully configured (2 PSU, 16 drives)	32	70.55

## 2.3 System Level Environmental Limits

The following table defines the system level operating and non-operating environmental limits.

**Table 5. System Environmental Limits Summary**

Parameter		Limits
Temperature		
	Operating	ASHRAE Class A2 – Continuous Operation. 10°C to 35°C (50°F to 95°F) with the maximum rate of change not to exceed 10°C per hour
		ASHRAE Class A3 – Includes operation up to 40°C for up to 900 hours per year.
		ASHRAE Class A4 – Includes operation up to 45°C for up to 90 hours per year.
	Shipping	-40°C to 70°C (-40°F to 158°F)
Humidity		
	Non-Operating	50% to 90%, non-condensing with a maximum wet bulb of 28°C (at temperatures from 25°C to 35°C)
Shock		
	Operating	Half sine, <a href="#">2g</a> , 11 mSec
	Unpackaged	Trapezoidal, <a href="#">25g</a> , velocity change is based on packaged weight
	Packaged	Product Weight: ≥ 40 to < 80 Non-palletized Free Fall Height = 18 inches Palletized (single product) Free Fall Height = NA
Vibration		
	Unpackaged	5 Hz to 500 Hz 2.20 g RMS random
	Packaged	5 Hz to 500 Hz 1.09 g RMS random
AC-DC		
	Voltage	90V to 132V and 180V to 264
	Frequency	47Hz to 63Hz
	Source Interrupt	No loss of data for power line drop-out of 12 mSec
	Surge Non-operating and operating	Unidirectional
	Line to earth Only	AC Leads 2.0 kV I/O Leads 1.0 kV DC Leads 0.5 kV
ESD		
	Air Discharged	8.0 kV

Parameter	Limits	
	Contact Discharge	8.0 kV
Altitude		
	Operating	-16 to 3048 m (-50 to 10,000 ft) <b>Note:</b> For altitudes above 2950 feet, the maximum operating temperature is derated 1°F/550 ft.
	Storage	-16 to 10,600 m (-50 to 35,000 ft)
Acoustics Sound Power Measured	–	–
	Power in Watts	All range
	Servers/Rack Mount BA	- 3.5" HDD SKU: 6.9BA at idle and 7.4BA at active mode - 2.5" HDD SKU: 6.5BA at idle and 7.07BA at active mode.

**Note:**

Intel Corporation server boards contain a number of high-density VLSI and power delivery components that need adequate airflow to cool. Intel ensures through its own chassis development and testing that when Intel server building blocks are used together, the fully integrated system will meet the intended thermal requirements of these components. It is the responsibility of the system integrator who chooses not to use Intel developed server building blocks to consult vendor datasheets and operating parameters to determine the amount of airflow required for their specific application and environmental conditions. Intel Corporation cannot be held responsible, if components fail or the server board does not operate correctly when used outside any of its published operating or non-operating limits.

---

**Disclaimer Note:** Intel ensures the unpackaged server board and system meet the shock requirement mentioned above through its own chassis development and system configuration. It is the responsibility of the system integrator to determine the proper shock level of the board and system if the system integrator chooses different system configuration or different chassis. Intel Corporation cannot be held responsible if components fail or the server board does not operate correctly when used outside any of its published operating or non-operating limits.

---

In order to maintain comprehensive thermal protection, deliver the best system acoustics, and improve fan power efficiency, an intelligent Fan Speed Control (FSC) and thermal management technology (mechanism) is used. Options in <F2> BIOS Setup (**BIOS > Advanced > System Acoustic and Performance Configuration**) allow for parameter adjustments based on the actual system configuration and usage. Refer to the following sections for a description of each setting.

### 2.3.1 High Temperature Ambience (HTA) Support

To keep the system operating within supported maximum thermal limits, the system must meet the following operating and configuration guidelines:

- The system operating ambient is designed for sustained operation up to 35°C (ASHRAE Class A2) with short term excursion based operation up to 45°C (ASHRAE Class A4).
  - The system can operate up to 40°C (ASHRAE Class A3) for up to 900 hours per year.
  - The system can operate up to 45°C (ASHRAE Class A4) for up to 90 hours per year.

- System performance may be impacted when operating within the extended operating temperature range.
- There is no long term system reliability impact when operating at the extended temperature range within the approved limits.
- Specific configuration requirements and limitations are documented in the configuration matrix found in the *Intel® Server Board S2600JF Product Family Power Budget and Thermal Configuration Guidelines Tool*, available as a download tool online at [http://www.intel.com/p/en\\_US/support/](http://www.intel.com/p/en_US/support/).
- The CPU-1 processor + CPU heat sink must be installed first. The CPU-2 heat sink must be installed at all times, with or without a processor installed.
- Memory Slot population requirements:

---

**Note:** Specified memory slots can be populated with a DIMM or supplied DIMM Blank. Memory population rules apply when installing DIMMs.

---

- **DIMM Population Rules on CPU-1** – Install DIMMs in order; Channels A, B, C, and D.
- **DIMM Population on CPU-2** – Install DIMMs in order; Channels E, F, G, and H.
- The following system configurations require that specific memory slots be populated at all times using either a DIMM or supplied DIMM Blank
- System Configuration – 16x 2.5" hard drive bay or 12x 3.5" hard drive bay configuration + Intel® Server Board S2600JF (8-DIMM server board)
- All hard drive bays must be populated. Hard drive carriers can be populated with a hard drive or supplied drive blank.
- With the system operating, the air duct must be installed at all times.
- In single power supply configurations, the second power supply bay must have the supplied filler blank installed at all times.
- Thermally, the system can support the following PCI add-in cards:
  - Add-in cards with a minimum 100 LFM (0.5 m/s) air flow requirement can be installed in any available add-in card slot in both Riser Card #1 and Riser Card for IO Module carrier.
  - Add-in cards with a >200 LFM air flow requirement cannot be supported.

---

**Note:** Most PCI add-in cards have minimum air flow requirements of 100 LFM (0.5m/s). Some high power add-in cards have minimum air flow requirements of 200 LFM (1 m/s). System integrators must verify PCI add-in card air flow requirements from vendor specifications when integrating add-in cards into the system.

---

- The system top-cover must be installed at all times when the system is in operation.
- Supported ambient temperature versus processor TDP is as follows.

**Table 6. Ambient Temperature versus System Configuration**

Notes:									
<ol style="list-style-type: none"> <li>1. 25°C is limited to elevations of 900m or less.</li> <li>2. Quad Port IO Modules cannot be installed simultaneously with PCI Cards.</li> <li>3. Processor – 130W-4C and 135W-8C may have some performance impact.</li> <li>4. Processors – There may be some performance impact during fan failures.</li> <li>5. For A3/A4 individual PS selection:               <ol style="list-style-type: none"> <li>a. For dual power supply configuration, power budget must fit within single power supply rated load and be installed in dual configuration, or</li> <li>b. For single power supply configuration, power budget must be sized with 30% margin to single power supply rated load.</li> </ol> </li> <li>6. LV refers to low voltage DIMMs (1.35V).</li> <li>7. When identifying memory in the table, only Rank and Width are required. Capacity is not required.</li> <li>8. Fan fail of dual-rotor fans refers to one rotor fail. "Fan Fail Support" indicates whether fan fail can be supported with specified configuration in each column.</li> </ol>		Base System SKUs: <b>H2216JF</b>			Base System SKUs: <b>H2312JF</b>				
ASHRAE (See note 1)	Classifications	A2	A3	A4	25C	A2	A3	A4	
	Max Ambient	35C	40C	45C	25C	35C	40C	45C	See note 1
Cooling (See note 8)	Redundant Fan Configuration	•	•	•	•	•	•	•	
	Fan Fail Support	•			•	•			
PS (See note 5)	Power Supplies	See Power Budget Tool			See Power Budget Tool				See note 5
EP Processors (See notes 3 and 4)	Intel® Xeon® processor E5-2630L, 60w, 6C	•	•		•	•	•		See note 4
	Intel® Xeon® processor E5-2650L, 70w, 8C	•	•	•	•	•	•		See note 4

	Intel® Xeon® processor E5-2620, E5-2630, E5-2640, 95w, 6C	•	•	•	•	•	•	•	See note 4
	Intel® Xeon® processor E5-2650, E5-2660, 95w, 8C	•	•	•	•	•	•	•	See note 4
	Intel® Xeon® processor E5-2665, E5-2670, 115w, 8C	•	•	•	•	•	•		See note 4
	Intel® Xeon® processor E5-2667, 130w, 6C	•	•	•	•	•			See note 4
	Intel® Xeon® processor E5-2680, 130w, 8C	•			•	•			See note 4
	Intel® Xeon® processor E5-2690, 135w, 8C	•			•				
	Intel® Xeon® processor E5-2637, 80w, 2C	•	•	•	•	•	•	•	See note 4
	Intel® Xeon® processor E5-2603, E5-2609, 80w, 4C	•	•	•	•	•	•	•	See note 4
	Intel® Xeon® processor E5-2643, 130w, 4C	•			•				
Memory Type (See note 6 and 7)	Dual Rank x8	•	•	•	•	•	•	•	
	Dual Rank x4	•	•		•	•	•		
	Quad Rank x8	•	•		•	•	•		
	Quad Rank x4	•			•	•			
	Load Reduced DIMM	•			•	•			
Add-in Cards (See note 2)	PCI Cards	•	•	•	•	•	•	•	See note 2
Module (See note 2)	AXX10GBTWLIOM – Dual 10GBASE-T IO Module	•	•	•	•	•	•	•	
	AXX10GBNIAIOM – Dual SFP+ port 10GbE IO Module	•	•	•	•	•	•	•	
	AXX1FDRIBIOM – Single Port FDR Infiniband* IO Module	•	•	•	•	•	•	•	
	AXX2FDRIBIOM – Dual Port FDR Infiniband* IO Module	•	•	•	•	•	•	•	
	AXX4P1GBPWLIO – Quad Port 1GbE IO Module	•	•	•	•	•	•	•	See note 2

### 2.3.2 Set Throttling Mode

This option is used to select the desired memory thermal throttling mechanism. Available settings include [Auto], [DCLTT], [SCLTT], and [SOLTT].

**[Auto]** – Factory Default Setting: BIOS automatically detects and identifies the appropriate thermal throttling mechanism based on DIMM type, airflow input, and DIMM sensor availability.

**[DCLTT]** – Dynamic Closed Loop Thermal Throttling: For the SOD DIMM with system airflow input

**[SCLTT]** – Static Close Loop Thermal Throttling: For the SOD DIMM without system airflow input

**[SOLTT]** – Static Open Loop Thermal Throttling: For the DIMMs without sensor on DIMM (SOD)

### 2.3.3 Altitude

This option is used to select the proper altitude that the system will be used in. Available settings include: [300m or less], [301m-900m], [901m-1500m], [Above 1500m].

Selecting an altitude range that is lower than the actual altitude the system will be operating at, can cause the fan control system to operate less efficiently, leading to higher system thermals and lower system performance. If the altitude range selected is higher than the actual altitude the system will be operating at, the fan control system may provide better cooling but with higher acoustics and higher fan power consumption. If the altitude is not known, selecting a higher altitude is recommended in order to provide sufficient cooling.

### 2.3.4 Set Fan Profile

This option is used to set the desired Fan Profile. Available settings include [Performance] and [Acoustic].

The Acoustic mode offers the best acoustic experience and appropriate cooling capability covering the mainstream and the majority of the add-in cards used. Performance mode is designed to provide sufficient cooling capability covering all kinds of add-in cards on the market.

### 2.3.5 Fan PWM Offset

This option is reserved for manual adjustment to the minimum fan speed curves. The valid range is from [0 to 100] which stands for 0% to 100% PWM adding to the minimum fan speed. This feature is valid when Quiet Fan Idle Mode is at Enabled state. The default setting is [0].

### 2.3.6 Quiet Fan Idle Mode

This feature can be [Enabled] or [Disabled]. If enabled, the fans will either shift to lower speeds or stop when the aggregate sensor temperatures are satisfied, indicating the system is at ideal thermal/light loading conditions. When the aggregate sensor temperatures are not satisfied, the fans will shift back to normal control curves. If disabled, the fans will never shift to lower fan speeds or stop, regardless of whether the aggregate sensor temperatures are satisfied. The default setting is [Disabled].

---

**Note:** The feature above may or may not be in effect and depends on the actual thermal characteristics of the specified system.

---

### 2.3.7 Thermal Sensor Input for Fan Speed Control

The BMC uses various IPMI sensors as inputs to fan speed control. Some of the sensors are actual physical sensors and some are “virtual” sensors derived from calculations.

The following IPMI thermal sensors are used as input to fan speed control:

- Front Panel Temperature Sensor <sup>1</sup>
- Server board Temperature Sensor <sup>2</sup>
- Processor Margin Sensors <sup>3, 5, 6</sup>
- DIMM Thermal Margin Sensors <sup>3, 5</sup>
- Exit Air Temperature Sensor <sup>1, 4, 8</sup>
- Chipset Temperature Sensor <sup>4,6</sup>
- On-board Ethernet Controller Temperature Sensors <sup>4, 6</sup>
- Add-In Intel SAS/IO Module Temperature Sensors <sup>4, 6</sup>
- Power Supply Thermal Sensor <sup>4, 9</sup>
- Processor VR Temperature Sensors <sup>4, 7</sup>
- DIMM VR Temperature Sensors <sup>4, 7</sup>
- BMC Temperature Sensor <sup>4, 7</sup>
- Global Aggregate Thermal Margin Sensors <sup>8</sup>

**Notes:**

1. For fan speed control in Intel chassis
2. For fan speed control in 3rd party chassis
3. Temperature margin from throttling threshold
4. Absolute temperature
5. PECI value or margin value
6. On-die sensor
7. On-board sensor
8. Virtual sensor
9. Available only when PSU has PMBus\*



The following diagram illustrates the fan speed control structure.

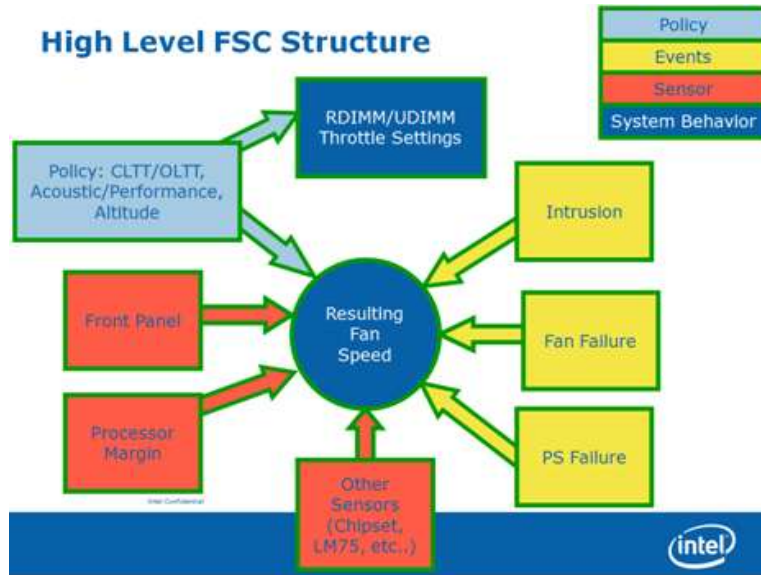
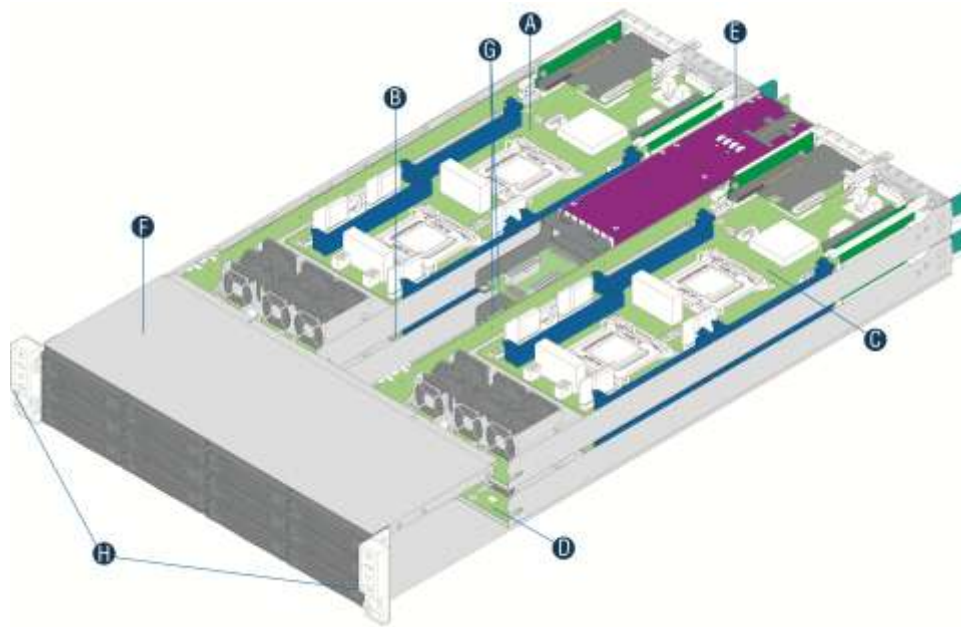

Figure 3. Fan Control Model

## 2.4 System Parts



<b>A</b>	Compute Node 3 Tray	<b>E</b>	Common Redundant Power Supply
<b>B</b>	Compute Node 1 Tray	<b>F</b>	HDD bays with Hot Swap Backplane
<b>C</b>	Compute Node 4 Tray	<b>G</b>	Upper and Lower Power Distribution Boards
<b>D</b>	Compute Node 2 Tray	<b>H</b>	Front Control Panel

**Note:** Not shown – Rack slide rail and top cover.

Figure 4. Major System Parts

## 2.5 Hard Drive and Peripheral Bays

	Intel® Server System H2312JF	Intel® Server System H2216JF
Slim-line SATA Optical Drive	Not Supported	Not Supported
Internal USB Floppy Drive	Not Supported	Not Supported
SATA/SAS Hard Disk Drives (3.5-inch)	Up to 12	Not Supported
SATA/SAS Hard Disk Drives (2.5-inch)	Not Supported	Up to 16
SATA DOM	Support	Support

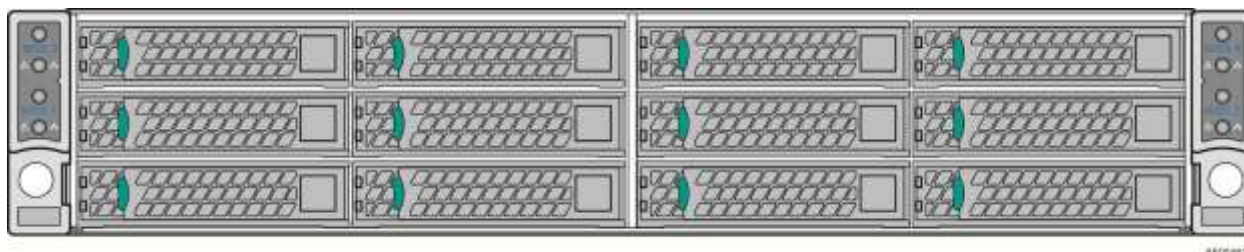

Figure 5. Intel® Server System H2312JF Drive Bay Overview

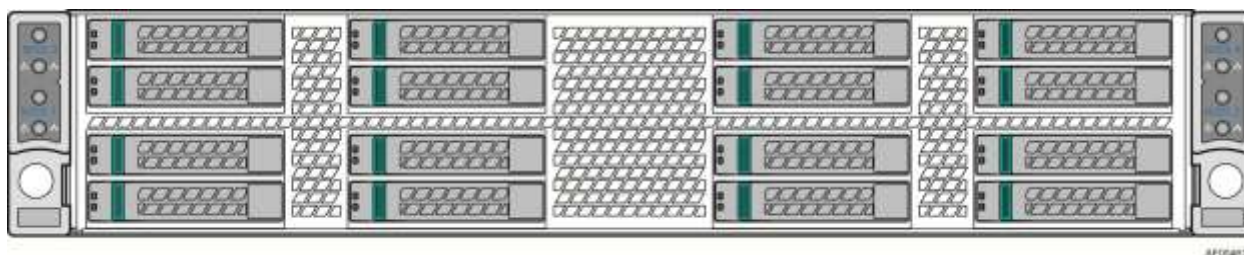

Figure 6. Intel® Server System H2216JF Drive Bay Overview

## 2.6 Server Board Overview

The chassis is mechanically and functionally designed to support half-width server board, including Intel® Server Board S2600JF. The following sections provide an overview of the server board feature sets.



Figure 7. Intel® Server Board S2600JFQ/S2600JFF

The following figure shows the layout of the server board. Each connector or major component is identified by a number or letter, and a description is given in the following figure.

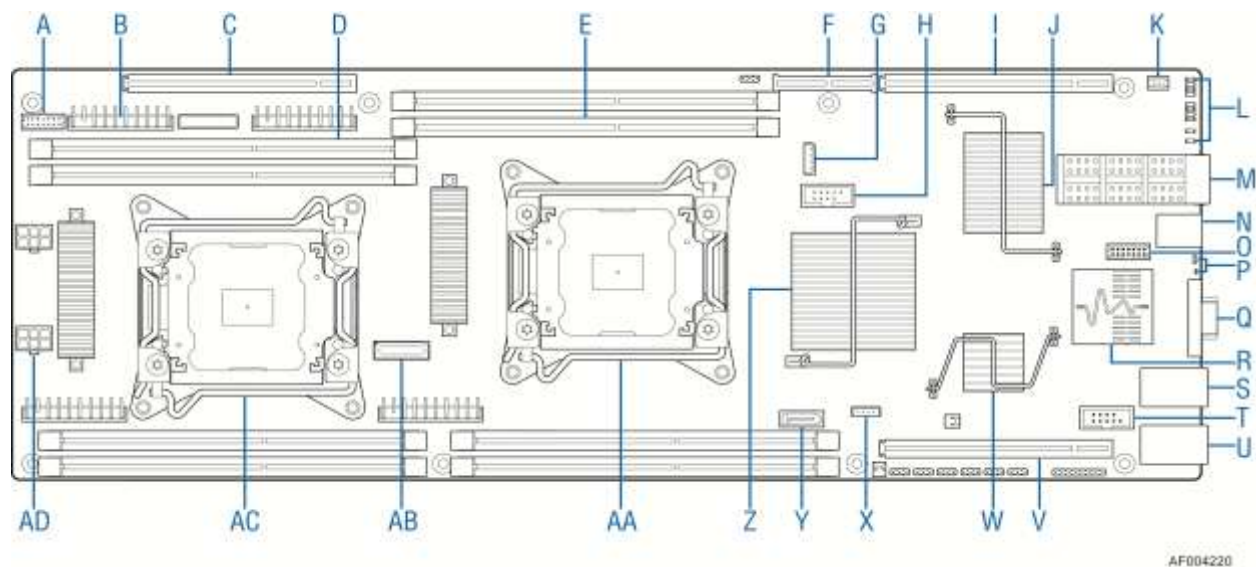

AF004220

<b>A</b>	2x7 fan control connector	<b>I</b>	Slot2 (PCIe Gen3x16)	<b>Q</b>	VGA out	<b>Y</b>	SATA port 1
<b>B</b>	VRS (4 total)	<b>J</b>	Infiniband* QDR/FDR	<b>R</b>	Dual port 1Gbe NIC	<b>Z</b>	PCH C600
<b>C</b>	Slot3 (PCIe Gen3x16)	<b>K</b>	RMM4 lite	<b>S</b>	NIC Port 2	<b>AA</b>	CPU 1
<b>D</b>	CPU2 DIMM (4 total)	<b>L</b>	POST and InfiniBand* Status LED	<b>T</b>	Serial Port A	<b>AB</b>	XDP connector
<b>E</b>	CPU1 DIMM (4 total)	<b>M</b>	QSFP	<b>U</b>	NIC Port 1	<b>AC</b>	CPU 2

<b>F</b>	Bridge board connector	<b>N</b>	USB x2	<b>V</b>	Slot1 (PCIe Gen3x16)	<b>AD</b>	2x3 PWR connector (2 total)
<b>G</b>	IPMB	<b>O</b>	Debug connector	<b>W</b>	Integrated BMC		
<b>H</b>	2x5 USB	<b>P</b>	Status and ID LED	<b>X</b>	Storage Upgrade key		

Figure 8. Intel® Server Board S2600JF Components

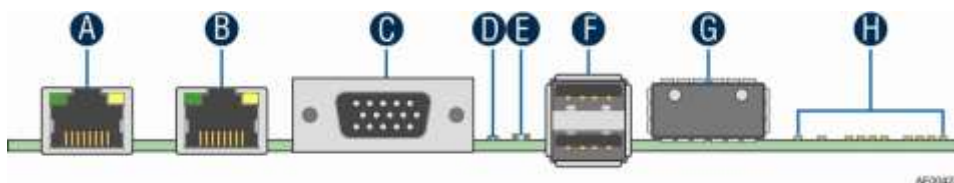

	Description		Description
<b>A</b>	NIC port 1 (RJ45) <sup>1</sup>	<b>E</b>	Status LED
<b>B</b>	NIC port 2 (RJ45) <sup>1</sup>	<b>F</b>	Dual port USB connector
<b>C</b>	DB15 video out	<b>G</b>	QSFP Connector <sup>2</sup>
<b>D</b>	ID LED	<b>H</b>	QSFP status and Diagnostic LED

Figure 9. Back Panel Feature Overview

**Note 1:** The Intel® Server System H2312JF and H2216JF require the use of shielded LAN cable to comply with Emission/Immunity regulatory requirements. Use of non shield cables may result in product non-compliance.

**Note 2:** The Intel® Server System H2312JFF and H2216JFF are recommended to use two meters or three meters length cables for better EMI performance.

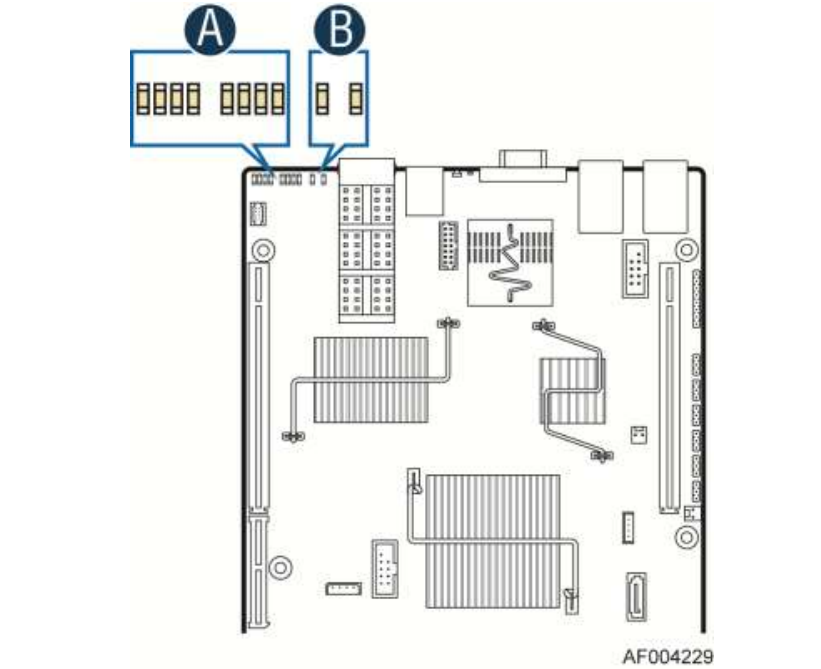

<b>A</b>	Diagnostic LED Group	<b>B</b>	QSFP Link/Activity LED
----------	----------------------	----------	------------------------

Figure 10. Light-Guided Diagnostic LED Locations(Block A)

## 2.7 Front Bezel Support

Intel® Server System H2000JF family provides front panel bezel. The bezel provides protection to system HDD bays with a lock to chassis. The front view of the bezel is as below.

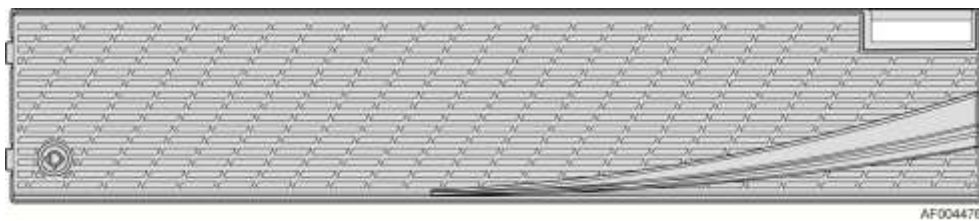

Figure 11. System Bezel Front View

## 2.8 Rack and Cabinet Mounting Options

The chassis is designed to support 19 inches wide by up to 30 inches deep server cabinets. The system bundles with the following Intel rack mount option:

- A basic slide rail kit (Product order code – **AXXELVRAIL**) is designed to mount the chassis into a standard (19 inches by up to 30 inches deep) EIA-310D compatible server cabinet.

---

**Caution:** THE MAXIMUM RECOMMENDED SERVER WEIGHT FOR THE RACK RAILS CAN BE FOUND at <http://www.intel.com/support/motherboards/server/sb/CS-033655.htm>. EXCEEDING THE MAXIMUM RECOMMENDED WEIGHT OR MISALIGNMENT OF THE SERVER MAY RESULT IN FAILURE OF THE RACK RAILS HOLDING THE SERVER. Use of a mechanical assist to install and align server into the rack rails is recommended.

---

---

**Advisory Note:** The AXXELVRAIL value rack mount rail kit is not designed to support shipment of the server system while installed in a rack.

---

---

**Advisory Note:** The AXXELVRAIL only supports specific rack type with 3/8" square and 7.1mm round holes.

---

## 3. Power Subsystem

The system supports AC 1+1 hot swap power supply module and two power distribution board which can support 2U rack high density server system. Two different power supply units are supported: 1200W and 1600W. The single power supply module has Platinum level energy efficiency, demonstrating climate saver with silver rating.

### 3.1 Mechanical Overview

The power supply module has a simple retention mechanism to retain the module self after it is inserted. This mechanism withstands the specified mechanical shock and vibration requirements. The power distribution board is fixed in the chassis with screws. This specification defines a 1+1 hot swap redundancy power supply that supports 2U server system. Using existing power supply module provided by vendor with updated PMBus\* and custom-made power connector board supports four nodes of Intel® Server Board S2600JF. The power supply has two outputs: 12V and 12VSB. The input is auto ranging and power factor corrected. The PMBus\* features included in this specification are requirements for AC silver rated box power supply for use in server systems based on Intel® Server System H2000JF Family. This specification is based on the *PMBus\* Specifications part I and II, revision 1.1*.

#### 3.1.1 AC Power Supply Unit Dimension Overview

The casing dimension is 73.5mm x 265.0mm x 39/40mm (W x L x H). The power supply contains a single 40mm fan. The power supply has a card edge output that interfaces with a 2x25 card edge connector in the system. The AC plugs directly into the external face of the power supply.

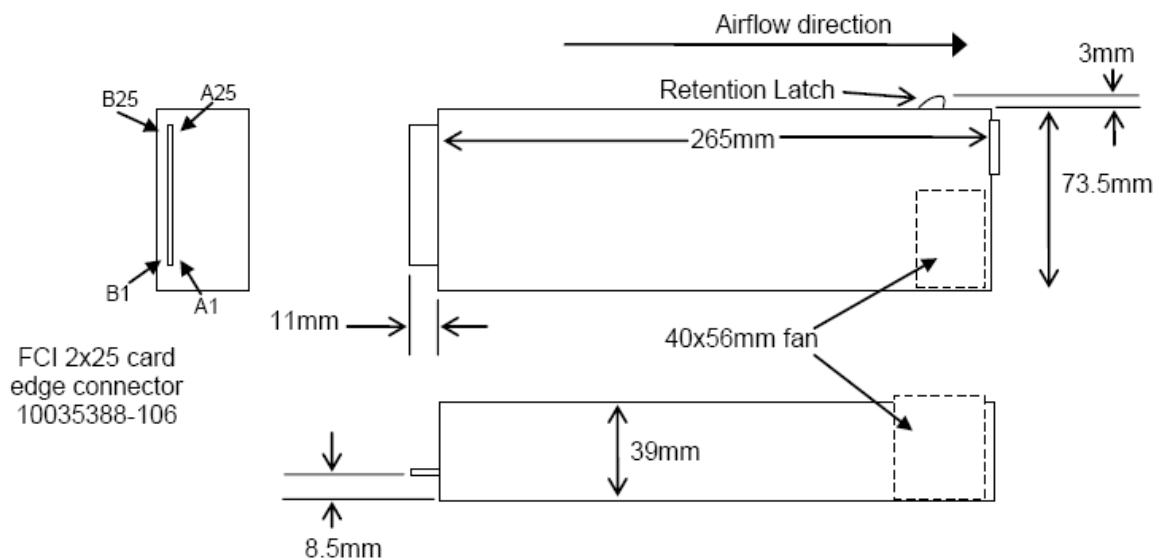

Figure 12. AC Power Supply Unit Dimension Overview

### 3.1.2 AC Power Supply Unit General Data

Following is general specification data for AC Power Supply Unit.

**Table 7. Specification Data for AC Power Supply Unit**

Wattage	1200W/1600W (Energy Smart)
Voltage	90 – 264 VAC, auto-ranging, 47 Hz-63 Hz
Heat Dissipation	2560 BTU/hr
Maximum Inrush Current	Under typical line conditions and over the entire system ambient operating range, the inrush current may reach 65 A per power supply for 5 ms
80 Plus rating	Platinum
Climate Saver (CS) rating	Platinum

### 3.1.3 AC Input Connector

The power supply has an internal IEC320 C14 power inlet. The inlet is rated for a minimum of 10A at 250VAC.

### 3.1.4 AC Power Cord Specification Requirements

The AC power cord used meets the following specification requirements.

**Table 8. AC Power Cord Specification**

Cable Type	SJT
Wire Size	16 AWG
Temperature Rating	105°C
Amperage Rating	13A
Cable Type	SJT

### 3.1.5 Power Supply Unit DC Output Connector

The DC output connector pin-out is defined as follows.

**Table 9. DC Output Power Connector**

PSU Output Connector			
A1	GND	B1	GND
A2	GND	B2	GND
A3	GND	B3	GND
A4	GND	B4	GND
A5	GND	B5	GND
A6	GND	B6	GND
A7	GND	B7	GND
A8	GND	B8	GND
A9	GND	B9	GND
A10	+12V	B10	+12V
A11	+12V	B11	+12V
A12	+12V	B12	+12V
A13	+12V	B13	+12V
A14	+12V	B14	+12V
A15	+12V	B15	+12V
A16	+12V	B16	+12V
A17	+12V	B17	+12V
A18	+12V	B18	+12V



PSU Output Connector			
A19	PMBus* SDA*	B19	A0* (SMBus* address)
A20	PMBus* SCL*	B20	A1* (SMBus* address)
A21	PSON	B21	12V STBY
A22	SMBAlert#	B22	Cold Redundancy Bus*
A23	Return Sense	B23	12V load share bus
A24	+12V Remote Sense	B24	No Connect
A25	PWOK	B25	CRPS Compatibility Check pin*

\* Refer to *CRPS Common Requirements Specification*.

### 3.1.6 Handle Retention

The power supply has a handle to assist extraction. The module can be inserted and extracted without the assistance of tools. The power supply also has a latch which retains the power supply into the system and prevents the power supply from being inserted or extracted from the system when the AC power cord is pulled into the power supply.

The handle protects the operator from any burn hazard through the use of industrial designed plastic handle or equivalent material.

### 3.1.7 LED Marking and Identification

The power supply uses a bi-color LED, Amber and Green, for status indication. The following table shows the LED states for each power supply operating state.

**Table 10. Power Supply Status LED**

Power Supply Condition	LED State
Output ON and OK	Solid GREEN
No AC power to all power supplies	OFF
AC present / Only 12VSB on (PS off) or PS in Cold redundant state	1Hz Blink GREEN
AC cord unplugged or AC power lost, with a second power supply in parallel still with AC input power	Solid AMBER
Power supply warning events where the power supply continues to operate; high temp, high power, high current, slow fan	1Hz Blink Amber
Power supply critical event causing a shutdown; failure, OCP, OVP, Fan Fail	Solid AMBER
Power supply FW updating	2Hz Blink GREEN

### 3.1.8 Power Cage with Power Distribution Board

The power cage is at the middle of the chassis, consisting of two Power Distribution Boards (PDBs) to support Common Redundant Power Supplies (CRPS).

---

**Caution:** *Installing two Power Supply Units with different wattage ratings on a system is not supported. This does not provide Power Supply Redundancy and causes the system to log multiple errors.*

---

Following is the power system overview.

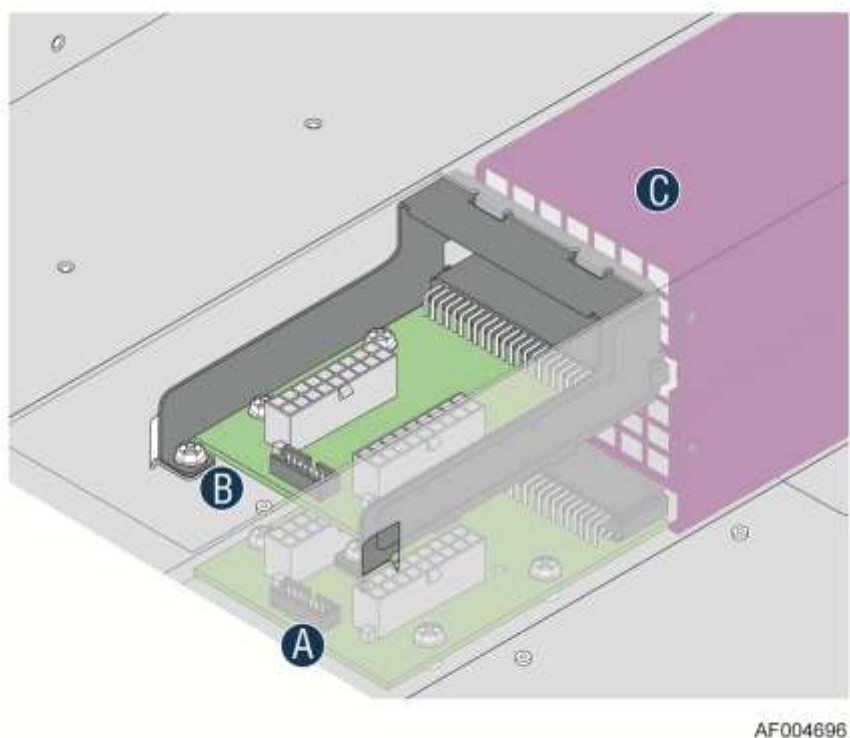

<b>A</b>	Power Distribution Board 1
<b>B</b>	Power Distribution Board 2
<b>C</b>	Power Supply Unit #2 (upper) and #1 (lower)

**Figure 13. Power Cage Overview**

### 3.1.9 Power Cage Output Pin Assignment

The power cage provides +12V and +12V<sub>STB</sub> output to the system. Each PDB has two 2x9 power output cables to system backplane, together with one 2x8 signal control cable for power management. Refer to the following table for PDB pin assignment.

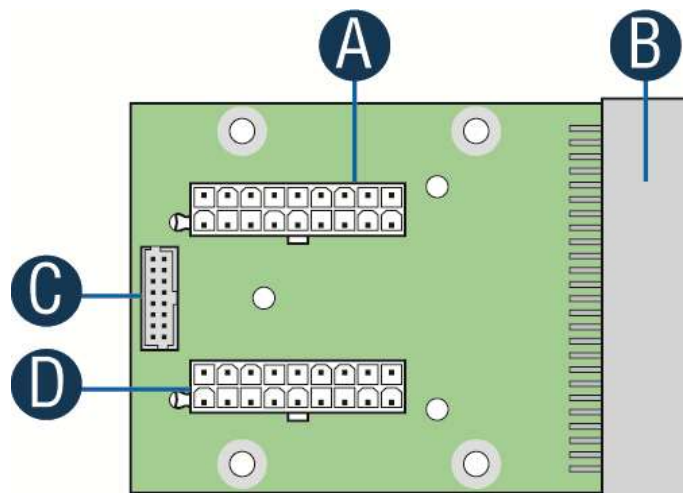

AF004432

<b>A</b>	Main Power Output Connector P1
<b>B</b>	Power Supply Unit Connector
<b>C</b>	Control Signal Connector
<b>D</b>	Main Power Output Connector P2

**Figure 14. Power Distribution Board**

**Table 11. Pin Assignment of Power Output Connector**

Pin	Description	Pin	Description
1	GND	2	+12V
3	GND	4	+12V
5	GND	6	+12V
7	GND	8	+12V
9	GND	10	+12V
11	GND	12	+12V
13	GND	14	+12V
15	GND	16	+12V
17	GND	18	+12V

**Table 12. Pin Assignment of Control Signal Connector**

Pin	Description	Pin	Description
1	PMBus* SDA	2	A0 (SMBus* Address)
3	PMBus* SCL	4	A1 (SMBus* Address)
5	PSO#	6	12V Load Share Bus
7	SMBAlert#	8	Cold Redundancy Bus

Pin	Description	Pin	Description
9	Return Sense	10	PWOK
11	+12V Remote Sense	12	Compatibility Bus
13	Reserved	14	+12VSB
15	+12VSB	16	Key Pin (removed)

## 3.2 AC Input Specification

### 3.2.1 Input Voltage and Frequency

The power supply operates within all specified limits over the following input voltage range. Harmonic distortion of up to 10% THD does not cause the power supply to go out of specific limits. The power supply is capable of start-up (power-on) with full rated power load, at line voltage as low as 90VAC.

**Table 13. AC Input Rating**

Parameter	Min	Rated	Max	Start up VAC	Power Off VAC
110V <sub>AC</sub>	90 V <sub>rms</sub>	100-127 V <sub>rms</sub>	140 V <sub>rms</sub>	85 V <sub>AC</sub> ± 4V <sub>AC</sub>	70V <sub>AC</sub> ±5V <sub>AC</sub>
220V <sub>AC</sub>	180 V <sub>rms</sub>	200-240 V <sub>rms</sub>	264 V <sub>rms</sub>		
Frequency	47 Hz	50/60 Hz	63 Hz		

**Note:**

1. Maximum input current at low input voltage range is measured at 90VAC, at max load.
2. Maximum input current at high input voltage range is measured at 180VAC, at max load.
3. This requirement is not to be used for determining agency input current markings.

### 3.2.2 AC Input Power Factor

The power supply meets the power factor requirements stated in the Energy Star Program Requirements for Computer Servers. These requirements are stated below.

**Table 14. Typical Power Factor**

Output Power	10% load	20% load	50% load	100% load
Power Factor	> 0.80	> 0.90	> 0.90	> 0.95

**Note:** Tested at 230VAC, 50Hz and 60Hz and 115VAC, 60Hz. Tested according to *Generalized Internal Power Supply Efficiency Testing Protocol*, Rev 6.4.3. This is posted at <http://efficientpowersupplies.epri.com/methods.asp>.

### 3.2.3 Efficiency

The following table provides the required minimum efficiency level at various loading conditions. These are provided at different load levels; 100%, 50%, 20%, and 10%. Output is loaded according to the proportional loading method defined by 80 Plus in *Generalized Internal Power Supply Efficiency Testing Protocol*, Rev 6.4.3. This is posted at: <http://efficientpowersupplies.epri.com/methods.asp>.

**Table 15. Platinum Efficiency Requirement**

Loading	100% of maximum	50% of maximum	20% of maximum	10% of maximum
Minimum Efficiency	91%	94%	90%	82%

The power supply passes with enough margin to make sure in production that all power supplies meet these efficiency requirements.

### 3.2.4 AC Line Fuse

The power supply has one line fused in the **single line fuse** on the line (Hot) wire of the AC input. The line fusing is acceptable for all safety agency requirements. The input fuse is a slow blow type. AC inrush current does not cause the AC line fuse to blow under any conditions. All protection circuits in the power supply do not cause the AC fuse to blow unless a component in the power supply has failed. This includes DC output load short conditions.

### 3.2.5 AC Line Inrush

The AC line inrush current does not exceed **65A peak** for up to one-quarter of the AC cycle, after which the input current is no more than the specified maximum input current. The peak inrush current is less than the ratings of its critical components (including input fuse, bulk rectifiers, and surge limiting device).

The power supply meets the inrush requirements for any rated AC voltage, during turn on at any phase of AC voltage, during a single cycle AC dropout condition as well as upon recovery after AC dropout of any duration, and over the specified temperature range ( $T_{op}$ ).

### 3.2.6 AC Line Dropout/Holdup

An AC line dropout is defined to be when the AC input drops to 0VAC at any phase of the AC line for any length of time. During an AC dropout the power supply meets dynamic voltage regulation requirements. An AC line dropout of any duration does not cause tripping of control signals or protection circuits. If the AC dropout lasts longer than the holdup time, the power supply will recover and meet all turn on requirements. The power supply meets the AC dropout requirement over rated AC voltages and frequencies. A dropout of the AC line for any duration does not cause damage to the power supply.

**Table 16. AC Power Holdup Requirement**

Loading	Holdup Time
70%	10.6 msec

The 12V<sub>STB</sub> output voltage stays in regulation under its full load (static or dynamic) during an AC dropout of **70ms min** (=12VSB holdup time) whether the power supply is in ON or OFF state (PSON asserted or de-asserted).

### 3.2.7 AC Line Fast Transient (EFT) Specification

The power supply meets the *EN61000-4-5* directive and any additional requirements in *IEC1000-4-5: 1995* and the Level 3 requirements for surge-withstand capability, with the following conditions and exceptions:

- These input transients do not cause any out-of-regulation conditions, such as overshoot and undershoot, nor cause any nuisance trips of any of the power supply protection circuits.
- The surge-withstand test does not produce damage to the power supply.

The supply meets surge-withstand test conditions under maximum and minimum DC-output load conditions.

### 3.2.8 Hot Plug

The power supply is designed to allow connection into and removal from the system without removing power to the system. During any phase of insertion, start-up, shutdown, or removal, the power supply does not cause any other modules in the system to deviate outside of their specifications. When AC power is applied, the auxiliary supply will turn on providing bias power internal to the supply and the 5VSB standby output.

### 3.2.9 Susceptibility Requirements

The power supply meets the following electrical immunity requirements when connected to a cage with an external EMI filter, which meets the criteria defined in the SSI document *EPS Power Supply Specification*. For further information on customer standards, request a copy of the customer *Environmental Standards Handbook*.

**Table 17. Performance Criteria**

Level	Description
A	The apparatus continues to operate as intended. No degradation of performance.
B	The apparatus continues to operate as intended. No degradation of performance beyond spec limits.
C	Temporary loss of function is allowed provided the function is self-recoverable or can be restored by the operation of the controls.

### 3.2.10 Electrostatic Discharge Susceptibility

The power supply complies with the limits defined in EN 55024: 1998 using the IEC 61000-4-2:1995 test standard and performance criteria B defined in Annex B of CISPR 24.

### 3.2.11 Fast Transient/Burst

The power supply complies with the limits defined in EN55024: 1998 using the IEC 61000-4-4:1995 test standard and performance criteria B defined in Annex B of CISPR 24.

### 3.2.12 Radiated Immunity

The power supply complies with the limits defined in EN55024: 1998 using the IEC 61000-4-3:1995 test standard and performance criteria A defined in Annex B of CISPR 24.

### 3.2.13 Surge Immunity

The power supply is tested with the system for immunity to AC Ring wave and AC Unidirectional wave, both up to 2kV, per EN 55024:1998, EN 61000-4-5:1995 and ANSI C62.45: 1992.

The pass criteria include: No unsafe operation is allowed under any condition; all power supply output voltage levels stay within proper spec levels; No change in operating state or loss of data during and after the test profile; No component damage under any condition.

The power supply complies with the limits defined in EN55024: 1998 using the IEC 61000-4-5:1995 test standard and performance criteria B defined in Annex B of CISPR 24.

### 3.2.14 AC Line Transient Specification

AC line transient conditions are defined as sag and surge conditions. Sag conditions are also commonly referred to as “brownout”; these conditions are defined as the conditions when the AC line voltage drops below nominal voltage. Surge conditions are defined as the conditions when the AC line voltage rises above nominal voltage.

The power supply meets the requirements under the following AC line sag and surge conditions.

**Table 18. AC Line Sag Transient Performance**

AC Line Sag (10 sec interval between each sagging)				
Duration	Sag	Operating AC Voltage	Line Frequency	Performance Criteria.
0 to ½ AC cycle	95%	Nominal AC Voltage ranges	50/60Hz	No loss of function or performance
> 1 AC cycle	>30%	Nominal AC Voltage ranges	50/60Hz	Loss of function acceptable, self-recoverable

**Table 19. AC Line Surge Transient Performance**

AC Line Surge				
Duration	Surge	Operating AC Voltage	Line Frequency	Performance Criteria
Continuous	10%	Nominal AC Voltages	50/60Hz	No loss of function or performance
0 to ½ AC cycle	30%	Mid-point of nominal AC Voltages	50/60Hz	No loss of function or performance

### 3.2.15 Power Recovery

The power supply recovers automatically after an AC power failure. AC power failure is defined to be any loss of AC power that exceeds the dropout criteria.

### 3.2.16 Voltage Interruptions

The power supply complies with the limits defined in EN55024: 1998/A1: 2001/A2: 2003 using the IEC 61000-4-11: Second Edition: 2004-03 test standard and performance criteria C defined in Annex B of CISPR 24.

### 3.2.17 AC Line Isolation

The power supply meets all safety agency requirements for dielectric strength. Transformers' isolation between primary and secondary windings complies with the 3000VAC (4242VDC) dielectric strength criteria. If the working voltage between primary and secondary dictates a higher dielectric strength test voltage, the highest test voltage will be used. In addition the insulation system complies with reinforced insulation per safety standard IEC 950. Separation

between the primary and secondary circuits, and primary to ground circuits, complies with the IEC 950 spacing requirements.

### 3.2.18 AC Power Inlet

The AC input connector is an *IEC 320 C-14* power inlet. This inlet is rated for 10A/250 VAC.

The AC power cord meets the following specification requirements.

Cable Type	SJT
Wire Size	16 AWG
Temperature Rating	105°C
Amperage Rating	13 A
Voltage	125V

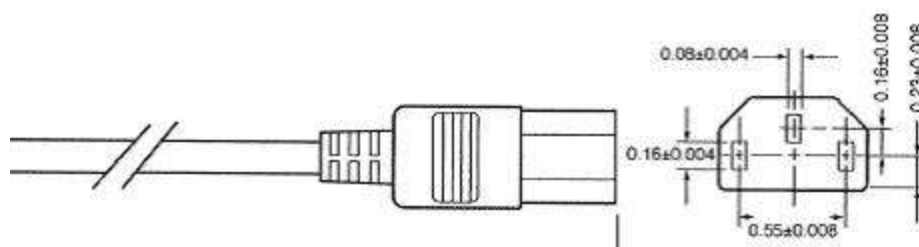

Figure 15. AC Power Cord Specification

## 3.3 DC Output Specification

### 3.3.1 Output Power/Currents

The following table defines the minimum power and current ratings. The power supply meets both static and dynamic voltage regulation requirements for all conditions.

Table 20. Load Ratings for Single Power Supply Unit

Parameter	Min	Max		Peak <sup>2,3</sup>		Unit
		1200W	1600W	1200W	1600W	
PSU SKU		1200W	1600W	1200W	1600W	
+12V main (200-240VAC)	0.0	100	133	133	175	A
+12V main (100-127VAC)	0.0	83	83	110	110	A
+12V <sub>STB</sub>	0.0	3.0	3.5	3.5	2.4	A

**Note:**

1. 12V<sub>STB</sub> provides 4.0A with two power supplies in parallel. The power supply fan is allowed to run in standby mode for loads > 1.5A.
2. Peak combined power for all outputs does not exceed 1600W (for 1200W PSU) and 2100W (for 1600W PSU).
3. Length of time peak power can be supported based on thermal sensor and assertion of the SMBAlert# signal. Minimum peak power duration is 20 seconds without asserting the SMBAlert# signal.

### 3.3.2 Standby Output

The 12V<sub>SB</sub> output is present when an AC input greater than the power supply turn on voltage is applied.



### 3.3.3 Voltage Regulation

The power supply output voltages stay within the following voltage limits when operating at steady state and dynamic loading conditions. These limits include the peak-peak ripple/noise. These are measured at the output connectors.

**Table 21. Voltage Regulation Limits**

Parameter	Min	Nom	Max	Unit	Tolerance
+12V <sub>STB</sub>	+11.40V	+12.000V	+12.60V	Vrms	±5%
+12V	+11.40V	+12.000V	+12.60V	Vrms	±5%

The combined output continuous power of all outputs does not exceed 3200W (1600W from each power supply unit). Each output has a maximum and minimum current rating shown in the table below. The power supply meets both static and dynamic voltage regulation requirements for the minimum dynamic loading conditions. The power supply meets only the static load voltage regulation requirements for the minimum static load conditions.

### 3.3.4 Dynamic Loading

The output voltages remain within limits specified for the step loading and capacitive loading specified in the table below. The load transient repetition rate is tested between 50Hz and 5kHz at duty cycles ranging from 10% to 90%. The load transient repetition rate is only a test specification. The  $\Delta$  step load may occur anywhere within the MIN load to the MAX load conditions.

**Table 22. Transient Load Requirements**

Output	$\Delta$ Step Load Size	Load Slew Rate	Test Capacitive Load
+12V <sub>STB</sub>	1.0A	0.25 A/ $\mu$ sec	20 $\mu$ F
+12V	60% of max load	0.25 A/ $\mu$ sec	2000 $\mu$ F

**Note:** For dynamic condition +12V min loading is 1A.

### 3.3.5 Capacitive Loading

The power supply is stable and meets all requirements with the following capacitive loading conditions.

**Table 23. Capacitive Loading Conditions**

Output	Min	Max	Units
+12V	500	25,000	$\mu$ F
+12V <sub>STB</sub>	20	3100	$\mu$ F

### 3.3.6 Ripple/Noise

The maximum allowed ripple/noise output of the power supply is defined in the table below. This is measured over a bandwidth of 10Hz to 20MHz at the power supply output connectors. A 10 $\mu$ F tantalum capacitor in parallel with a 0.1 $\mu$ F ceramic capacitor is placed at the point of measurement.

Table 24. Ripple and Noise

+12V	+12V <sub>STB</sub>
120mVp-p	120mVp-p

### 3.3.7 Grounding

The output ground of the pins of the power supply provides the output power return path. The output connector ground pins are connected to the safety ground (power supply enclosure). This grounding is well designed to ensure passing the max allowed Common Mode Noise levels.

The power supply is provided with a reliable protective earth ground. All secondary circuits are connected to protective earth ground. Resistance of the ground returns to chassis does not exceed 1.0 mΩ. This path may be used to carry DC current.

### 3.3.8 Closed Loop Stability

The power supply is unconditionally stable under all line/load/transient load conditions including capacitive load ranges specified in Section 4.6. A minimum of: **45 degrees phase margin** and **10dB-gain margin** is required. The power supply manufacturer provides proof of the unit's closed-loop stability with local sensing through the submission of Bode plots. Closed-loop stability is ensured at the maximum and minimum loads as applicable.

### 3.3.9 Residual Voltage Immunity in Standby Mode

The power supply is immune to any residual voltage placed on its outputs (Typically a leakage voltage through the system from standby output) up to **500mV**. There is no additional heat generated, nor stressing of any internal components with this voltage applied to any individual or all outputs simultaneously. It also does not trip the protection circuits during turn on.

The residual voltage at the power supply outputs for no load condition does not exceed **100mV** when AC voltage is applied and the PSON# signal is de-asserted.

### 3.3.10 Common Mode Noise

The Common Mode noise on any output does not exceed **350mVp-p** over the frequency band of 10Hz to 20MHz.

1. The measurement is made across a 100Ω resistor between each of DC outputs, including ground at the DC power connector and chassis ground (power subsystem enclosure).
2. The test set-up uses a FET probe such as Tektronix model P6046 or equivalent.

### 3.3.11 Soft Starting

The Power Supply contains control circuit which provides monotonic soft start for its outputs without overstress of the AC line or any power supply components at any specified AC line or load conditions.

### 3.3.12 Zero Load Stability Requirement

When the power subsystem operates in a no load condition, it does not need to meet the output regulation specification, but it must operate without any tripping of over-voltage or other fault circuitry. When the power subsystem is subsequently loaded, it begins to regulate and source current without fault.

### 3.3.13 Hot Swap Requirement

Hot swapping a power supply is the process of inserting and extracting a power supply from an operating power system. During this process the output voltages remain within the limits with the capacitive load specified. The hot swap test is conducted when the system is operating under static, dynamic, and zero loading conditions. The power supply uses a latching mechanism to prevent insertion and extraction of the power supply when the AC power cord is inserted into the power supply.

### 3.3.14 Forced Load Sharing

The +12V output has active load sharing. The output shares within 10% at full load. The failure of a power supply does not affect the load sharing or output voltages of the other supplies still operating. The supplies can load share in parallel and operate in a hot-swap/redundant **1+1** configurations. The 12VSB output is not required to actively share current between power supplies (passive sharing). The 12VSB outputs of the power supplies are connected together in the system so that a failure or hot swap of a redundant power supply does not cause these outputs to go out of regulation in the system.

### 3.3.15 Timing Requirement

These are the timing requirements for the power supply operation. The output voltages rise from 10% to within regulation limits ( $T_{vout\_rise}$ ) within 5 to 70ms. For 12VSB, it is allowed to rise from 1.0 to 25ms. **All outputs must rise monotonically.** Table below shows the timing requirements for the power supply being turned on and off through the AC input, with PSON held low and the PSON signal, with the AC input applied.

**Table 25. Timing Requirement**

Item	Description	Min	Max	Units
$T_{vout\_rise}$	Output voltage rise time.	5.0 *	70 *	ms
$T_{sb\_on\_delay}$	Delay from AC being applied to 12VSB being within regulation.		1500	ms
$T_{ac\_on\_delay}$	Delay from AC being applied to all output voltages being within regulation.		3000	ms
$T_{vout\_holdup}$	Time 12VI output voltage stay within regulation after loss of AC.	13		ms
$T_{pwok\_holdup}$	Delay from loss of AC to de-assertion of PWOK.	10.6		ms
$T_{pson\_on\_delay}$	Delay from PSON# active to output voltages within regulation limits.	5	400	ms
$T_{pson\_pwok}$	Delay from PSON# deactivate to PWOK being de-asserted.		5	ms
$T_{pwok\_on}$	Delay from output voltages within regulation limits to PWOK	100	500	ms

Item	Description	Min	Max	Units
	asserted at turn on.			
$T_{pwok\_off}$	Delay from PWOK de-asserted to output voltages dropping out of regulation limits.	1		ms
$T_{pwok\_low}$	Duration of PWOK being in the de-asserted state during an off/on cycle using AC or the PSON signal.	100		ms
$T_{sb\_vout}$	Delay from 12VSB being in regulation to O/Ps being in regulation at AC turn on.	50	1000	ms
$T_{12VSB\_holdup}$	Time 12VSB output voltage stays within regulation after loss of AC.	70		ms

**Note:** \* The 12V<sub>STB</sub> output voltage rise time is from 1.0ms to 25ms.

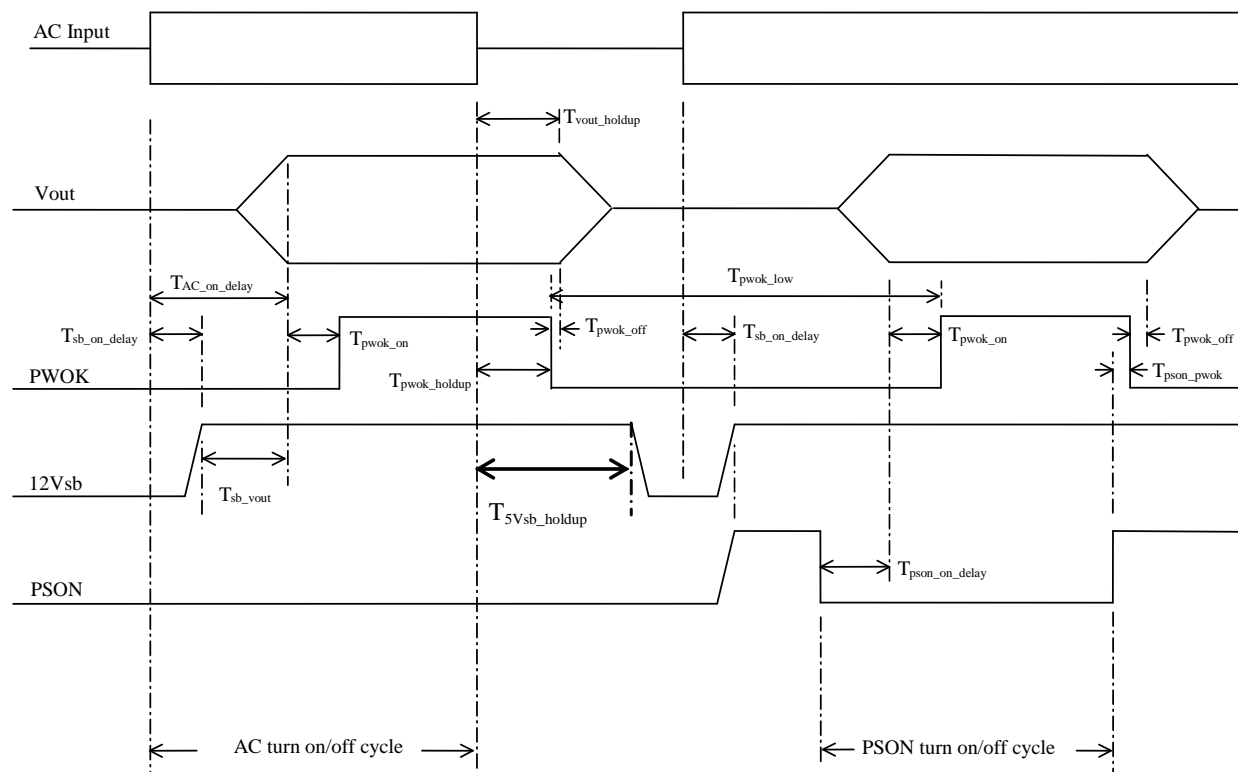

Figure 16. Turn On/Off Timing (Power Supply Signals)

### 3.4 Power Supply Cold Redundancy Support

Power supplies that support cold redundancy can be enabled to go into a low-power state (that is, cold redundant state) in order to provide increased power usage efficiency when system loads are such that both power supplies are not needed. When the power subsystem is in Cold Redundant mode, only the needed power supply to support the best power delivery efficiency is ON. Any additional power supplies, including the redundant power supply, are in Cold Standby state.

Each power supply has an additional signal that is dedicated to supporting Cold Redundancy, CR\_BUS. This signal is a common bus between all power supplies in the system. CR\_BUS is

asserted when there is a fault in any power supply OR the power supplies output voltage falls below the  $V_{\text{fault}}$  threshold. Asserting the CR\_BUS signal causes all power supplies in Cold Standby state to power ON.

Enabling power supplies to maintain best efficiency is achieved by looking at the Load Share bus voltage and comparing it to a programmed voltage level through a PMBus\* command.

Whenever there is no active power supply on the Cold Redundancy bus driving a HIGH level on the bus all power supplies are ON irrespective of their defined Cold Redundant roll (active or Cold Standby). This guarantees that incorrect programming of the Cold Redundancy states of the power supply will never cause the power subsystem to shut down or become over loaded. The default state of the power subsystem is all power supplies ON. There needs to be at least one power supply in Cold Redundant Active state or Standard Redundant state to allow the Cold Standby state power supplies to go into Cold Standby state.

---

**Caution:** *Installing two Power Supply Units with different wattage ratings on a system is not supported. This does not provide Power Supply Redundancy and causes the system to log multiple errors.*

---

### 3.4.1 1200W CRPS Cold Redundancy

If the output power is less than 480W (40%), the Cold redundant function will be enabled. Thus you will see one PSU working normal and the second PSU will be in CR mode. The Power Supply LED will be blinking green.

**Table 26. 1200W CRPS Cold Redundancy Threshold**

	Enable (V)	percent	power (W)	Disable (V)	percent	power (W)
Cold Standby 1 (02h)	3.2	40.00%	480(±5%)	1.44	18.00%	432(±5%)

### 3.4.2 1600W CRPS Cold Redundancy

If the output power is less than 640W (40%), the Cold redundant function will be enabled. Thus you will see one PSU working normal and the second PSU will be in CR mode. The Power Supply LED will be blinking green.

**Table 27. 1600W CRPS Cold Redundancy Threshold**

	Enable (V)	percent	power (W)	Disable (V)	percent	power (W)
Cold Standby 1 (02h)	3.2	40.00%	640(±5%)	1.44	18.00%	576(±5%)

## 3.5 Control And Indicator Functions

The following sections define the input and output signals from the power supply. Signals that can be defined as low true use the following convention: Signal# = low true

### 3.5.1 PSON# Input Signal

The PSON# signal is required to remotely turn on/off the power supply. PSON# is an active low signal that turns on the +12V power rail. When this signal is not pulled low by the system, or left open, the outputs (except the +12VSB) turn off. This signal is pulled to a standby voltage by a pull-up resistor internal to the power supply. Refer to the following table for the timing diagram.

**Table 28. PSON# Signal Characteristics**

Signal Type	Accepts an open collector/drain input from the system. Pull-up to VSB located in power supply.	
PSON# = Low	ON	
PSON# = High or Open	OFF	
	MIN	MAX
Logic level low (power supply ON)	0V	1.0V
Logic level high (power supply OFF)	2.0V	3.46V
Source current, $V_{pson} = \text{low}$		4mA
Power up delay: $T_{pson\_on\_delay}$	5msec	400msec
PWOK delay: $T_{pson\_pwok}$		50msec

### 3.5.2 PWOK (Power Good) Output Signal

PWOK is a power OK signal and will be pulled HIGH by the power supply to indicate that all the outputs are within the regulation limits of the power supply. When any output voltage falls below regulation limits or when AC power has been removed for a time sufficiently long so that power supply operation is no longer guaranteed, PWOK will be de-asserted to a LOW state. See the table below for a representation of the timing characteristics of PWOK. The start of the PWOK delay time is inhibited as long as any power supply output is in current limit.

**Table 29. PWOK Signal Characteristics**

Signal Type		
PWOK = High	Power OK	
PWOK = Low	Power Not OK	
	MIN	MAX
Logic level low voltage, $I_{sink}=400\mu\text{A}$	0V	0.4V
Logic level high voltage, $I_{source}=200\mu\text{A}$	2.4V	3.46V
Sink current, PWOK = low		400 $\mu\text{A}$
Source current, PWOK = high		2mA
PWOK delay: $T_{pwok\_on}$	100ms	1000ms
PWOK rise and fall time		100 $\mu\text{sec}$
Power down delay: $T_{pwok\_off}$	1ms	200msec

### 3.5.3 SMBAlert# Signal

This signal indicates that the power supply is experiencing a problem that the user should investigate. This is asserted due to Critical events or Warning events. The signal is activated in case the critical component temperature reaches a warning threshold, general failure, over-

current, over-voltage, under-voltage, or failed fan. This signal may also indicate the power supply is reaching its end of life or is operating in an environment exceeding the specified limits.

This signal is to be asserted in parallel with LED turning solid Amber or blinking Amber.

**Table 30. SMBAlert# Signal Characteristics**

Signal Type (Active Low)	Open collector/drain output from power supply. Pull-up to VSB located in system.	
Alert# = High	OK	
Alert# = Low	Power Alert to system	
	MIN	MAX
Logic level low voltage, Isink=4 mA	0 V	0.4 V
Logic level high voltage, Isink=50 $\mu$ A		3.46 V
Sink current, Alert# = low		4 mA
Sink current, Alert# = high		50 $\mu$ A
Alert# rise and fall time		100 $\mu$ s

## 3.6 Protection Circuits

Protection circuits inside the power supply cause only the power supply's main outputs to shut down. If the power supply latches off due to a protection circuit tripping, an AC cycle OFF for 15sec and a PSON# cycle HIGH for 1sec will be able to reset the power supply.

### 3.6.1 Current Limit (OCP)

The power supply has current limit to prevent the outputs from exceeding the values shown in table below. If the current limits are exceeded, the power supply will shut down and latch off. The latch will be cleared by toggling the PSON# signal or by an AC power interruption. The power supply will not be damaged from repeated power cycling in this condition. 12VSB will be auto-recovered after removing OCP limit.

**Table 31. Over Current Protection**

Output Voltage	Input Voltage Range	Over Current Limits	
		1200W	1600W
PSU SKU			
+12V	90 – 264VAC	140A min; 170A max	180A min; 200A max
+12V <sub>STB</sub>	90 – 264VAC	2.5A min; 3A max	2.5A min; 3A max

### 3.6.2 Over Voltage Protection (OVP)

The power supply over voltage protection is locally sensed. The power supply will shut down and latch off after an over voltage condition occurs. This latch will be cleared by toggling the PSON# signal or by an AC power interruption. The values are measured at the output of the power supply's connectors. The voltage does never exceed the maximum levels when measured at the power connectors of the power supply connector during any single point of fail. The voltage does never trip any lower than the minimum levels when measured at the power connector. 12VSB will be auto-recovered after removing OVP limit.

**Table 32. Over Voltage Protection (OVP) Limits**

Output Voltage	MIN (V)	MAX (V)
+12V	13.3	14.5
+12VSB	13.3	14.5

### 3.6.3 Over Thermal Protection (OTP)

The power supply is protected against over temperature conditions caused by loss of fan cooling or excessive ambient temperature. In an OTP condition the PSU will shut down. When the power supply temperature drops to within specified limits, the power supply will restore power automatically, while the 12VSB remains always on. The OTP circuit has built-in margin so that the power supply does not oscillate on and off due to temperature recovering condition. The OTP trip level has a minimum of 4°C of ambient temperature margin.

## 3.7 PMBus\*

The PMBus\* features are requirements for power supply unit for use in server systems. This specification is based on the *PMBus\* specifications part I and II, revision 1.1*. The power supply device address locations are shown below.

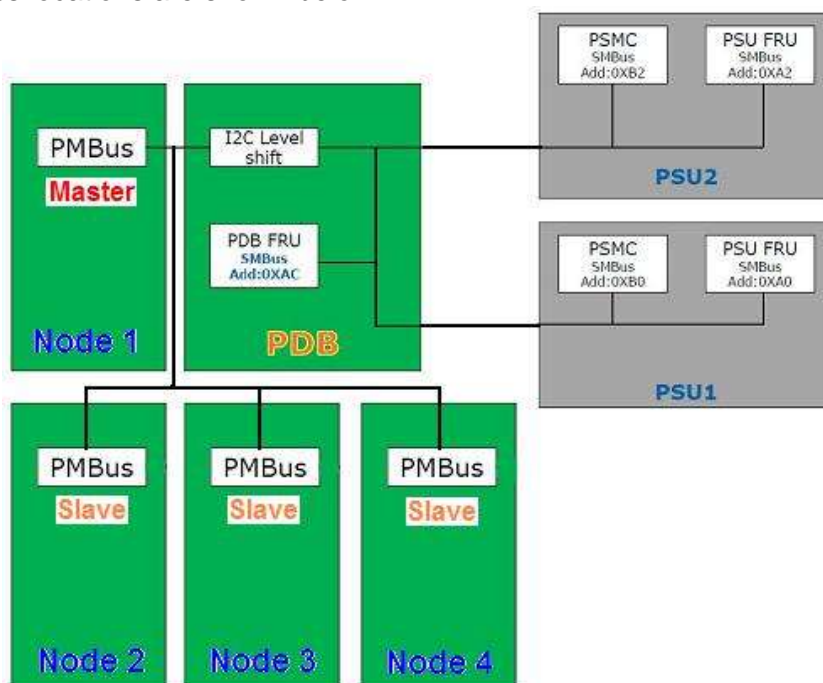
**Figure 17. Power Supply Device Address**

The PMBus\* from PDB is connected to BMC of all four nodes. Only one board BMC is assigned to be the master BMC and communicate with PSU as single point. Other board BMCs receive PSU data from the master BMC. In case the master BMC is down, one of the slave board BMC will be promoted automatically as master BMC and maintain communication.

### 3.7.1 PSU Address Lines A0

Address pins A0 is used by end use system to allocate unit address to a power supply in particular slot position.



For redundant systems there are two signals to set the address location of the power supply after it is installed in the system, Address0 and Address1. For non-redundant systems the power supply device address locations align with the Address0/Address1 location of 0/0.

**Table 33. PSU Addressing**

PDB addressing Address0	0	1
Power supply PMBus* device	B0h	B2h

### 3.7.2 Accuracy

The sensor commands meet the following accuracy requirements. The accuracies are met over the specified ambient temperature and the full range of rated input voltage.

**Table 34. PMBus\* Accuracy**

Output Loading	10% - 20%	> 20% - 50%	> 50% - 100%
READ_PIN and READ_EIN	See graphs below		
READ_FAN	+/-500 RPM		
READ_IOUT	+/-5%	+/-2%	+/-2%
READ_TEMPERATURE	+/- 3°C		

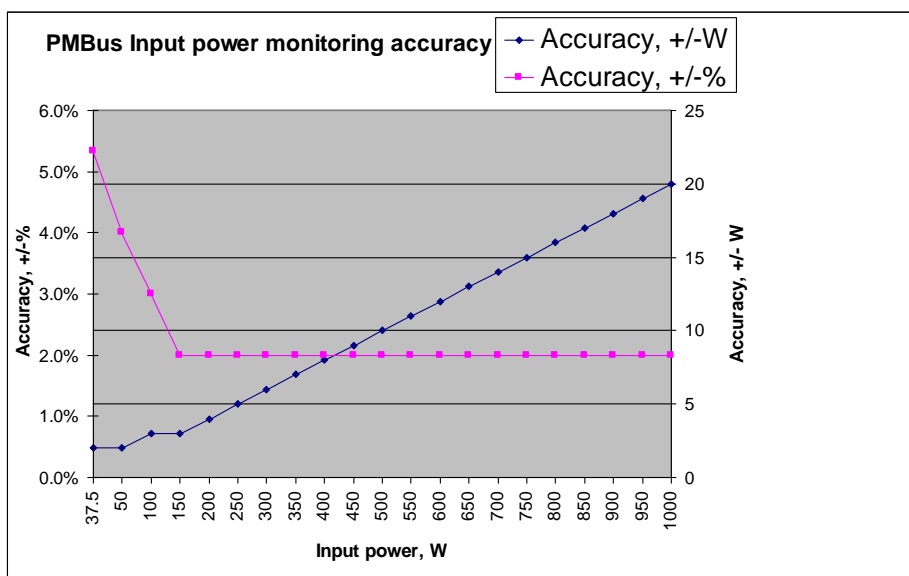

**Figure 18. PMBus\* Monitoring Accuracy**

## 3.8 Power Management Policy

When working with Intel® Server Board S2600JF, the BMC on each node will monitor its fans and temperature for critical failures. When there is a fan failure and a critical temperature event

at the same time, the node will be powered down. When this occurs, the node will need to be manually powered back on.

When system power is beyond 1200W or 1600W in 1+1 mode that it automatically shifts from 1+1 mode to 2+0 mode if power load is high so that would be expected behavior on H2000JF system.

Additionally on Intel® Server Board S2600JF, the BMC on node 3 and node 4 will monitor for a power supply over current condition or power supply over temperature condition. If either of these occurs and the Shutdown Policy has been enabled, the node will be powered down. When this occurs, the node will need to be manually powered back on. However, if the over current or over temperature event is detected again, the node will be powered back off. The following table shows the scheme of system power redundancy mode with node behavior.

**Table 35. Power Management Policy**

Intel® Server System H2000 Load with 2x 1200W supplies	Intel® Server System H2000 Load with 2x 1600W supplies	System Power Redundancy Mode	System behavior with one PSU AC lost or failed
System Power Load			
<1200W	<1600W	Unconstrained Redundant Mode	No system throttling. All four nodes work normally.
1200W < current load < 1800W	1600W < current load < 2160W	Optimal Redundant Mode	With BIOS setting “server management – shutdown policy” set to “disable”, all nodes in the system may be throttled to maintain power. This may cause lower performance. With BIOS “server management – shutdown policy” set to “enable”, Nodes 3 and 4 will shut down while Nodes 1 and 2 keep running without throttling. Node 1 and Node 2 will have no performance loss.
>1800W	>2160W	Non Redundant Mode	All nodes in the system may shut down.

The Shutdown Policy setting is only shown on Node 3 and Node 4, and is disabled by default but can be enabled or disabled in the BIOS setup Server Management page or by using the *Set Shutdown Policy* command.

---

**Caution:** *Installing two Power Supply Units with different wattage ratings on a system is not supported. This does not provide Power Supply Redundancy and causes the system to log multiple errors.*

---

## 4. Cooling Subsystem

---

The chassis cooling system contains the fan cooling subsystem of each node and common fan cooling in the power supply units. Both node fans and PSU fans work together as thermal solution to the chassis.

For each node, several components and configuration requirements make up the cooling subsystem. These include processors, chipsets, VR heatsinks, system fan module, CPU air duct, and drive bay population. All are necessary to provide and regulate the air flow and air pressure needed to maintain the system's thermals when operating at or below the maximum specified thermal limits.

In order to maintain the necessary airflow within the system, you must properly install the air duct, HDD dummy carrier, PSU dummy filler, and the top cover.

Each node uses a variable fan speed control engine to provide adequate cooling for the node and whole system at various ambient temperature conditions, under various server workloads, and with the least amount of acoustic noise possible. The fans operate at the lowest speed for any given condition to minimize acoustics.

---

**Note:** The server system does not support redundant cooling fans. If any of the node fans fail, you must power down the respective node as soon as possible to replace the fan.

---

### 4.1 Processor Heatsink

A heatsink is included in the system package. This heatsink is designed for optimal cooling and performance. To achieve better cooling performance, you must properly attach the heatsink bottom base with TIM (thermal interface material). ShinEtsu\* G-751 or 7783D or Honeywell\* PCM45F TIM is recommended. The mechanical performance of the heatsink must satisfy mechanical requirement of Intel® Xeon® E5-2600 series processors. To keep chipsets and VR temperature at or below maximum temperature limit, the heatsink is required if necessary.

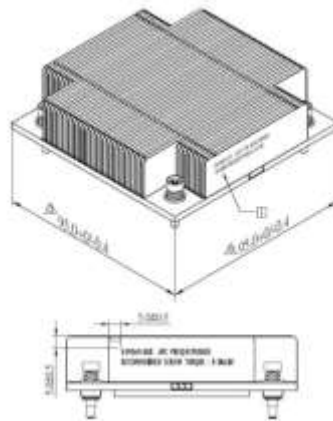

Figure 19. Processor Heatsink Overview

---

**Note:** The passive heatsink is Intel standard thermal solution for 1U/2U rack chassis.

---

## 4.2 Node Cooling Fans

The cooling subsystem for each node consists of three 40 x 40 x 56 dual rotor fans, and CPU air duct. These components provide the necessary cooling and airflow to the system node.

To maintain the necessary airflow within the system, the air duct and the top cover must be properly installed.

---

**Note:** The Intel® Server System H2000JF Family does not support redundant cooling. If one of the node fan fails, it is recommended to replace the failed fan as soon as possible.

---

However, the system design still reserves limited thermal margin to fan failure.

For Intel® Server System H2312JF with 12x 3.5" HDD, the system allows one fan fail at one time per node with ASHRAE-A2. Certain level of CPU throttling will occur during fan fail but the percent is below 1% which is considered to be acceptable from thermal perspective. For 130W CPU configuration, the confidence level of system exit air temperature to meet 70°C is 98% which is acceptable. For 95W CPU configuration, the system exit air temperature can meet 70°C specification. All other system components are within thermal specification.

For Intel® Server System H2216JF with 16x 2.5" HDD, the system allows one fan fail at one time per node with ASHRAE-A2. There is no throttling on CPU. All other system components are within thermal specification.

Each fan within the node can support multiple speeds. Fan speed changes automatically when internal ambient temperature of the system or processor temperature changes. The fan speed control algorithm is programmed into the server board's BIOS.

Each fan connector within the module supplies a tachometer signal that allows the BMC to monitor the status of each fan. If one of the fans fails, the system fault LED in the front panel will light up.

The fan control signal is from BMC on mother board to Node Docking Board and then distribute to three sets of dual rotor fans. See below for detail.

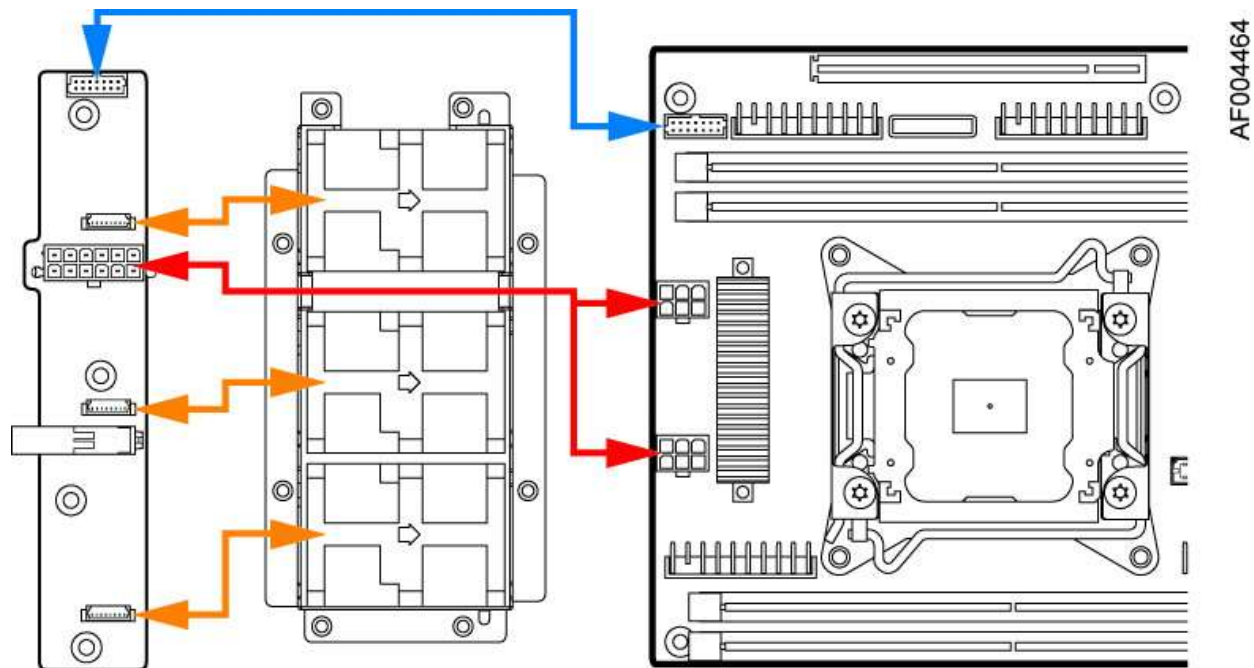

**Figure 20. Node Fan Set and Power/Control Connection**

The fan connector pin-out definition is as follows.

**Table 36. 8-Pin Connector Pin-Out for Node Dual Rotor Fans**

Pin	Signal Name	Description
1	GND	Ground
2	P12V	Power Supply +12 V
3	Tach1 Out	FAN_TACH1 signal output
4	PWM1 In	PWM1 signal input
5	GND	Ground
6	P12V	Power Supply +12 V
7	Tach2 Out	FAN_TACH2 signal output
8	PWM1 In	PWM1 signal input

### 4.3 Power Supply Fan

Each power supply module supports one non-redundant dual rotor 40 mm fan. The fans control the cooling of the power supply and some drive bays. These fans are not replaceable. Therefore, if a power supply fan fails, you must replace the power supply module.

### 4.4 Air Duct Module

Each node requires the use of an air duct module to direct airflow over critical areas within the node. Before slide the node tray into chassis, make sure the air duct is installed properly.

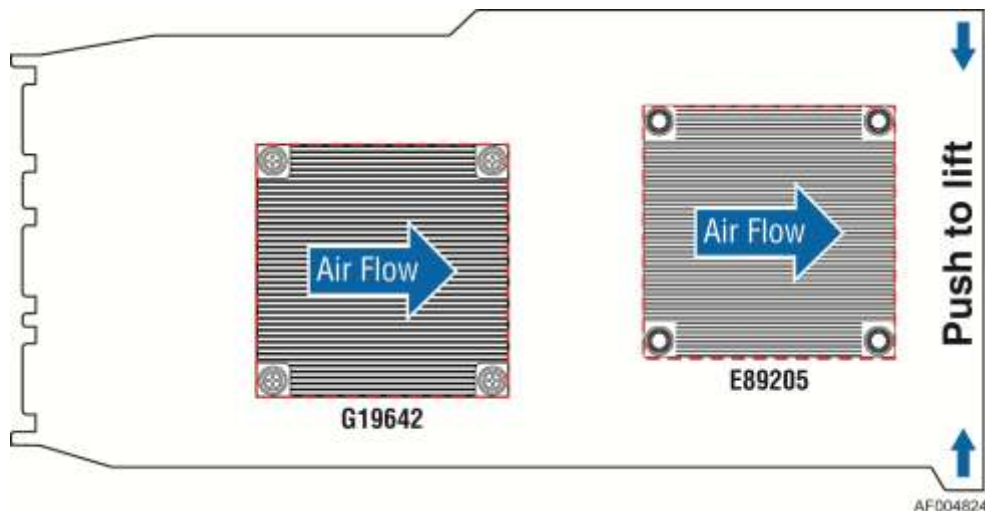

Figure 21. Compute Node Air Duct (Top View)

## 4.5 Drive Bay Population Requirement

In order to maintain system thermal requirements, you must fully populate all hard drive bays. Hard drive trays used for hot-swap drives must either have a hard drive installed or not have a hard drive installed.

If only one power supply unit is used, a PSU dummy filler must be used to match the airflow requirement.

---

**Important Note:** If the drive bay is missing or not fully populated, the system will not meet the thermal cooling requirements of the processor, which will most likely result in degraded performance as a result of throttling or thermal shutdown of the system. It is recommended to keep/apply the dummy plastic blocker (as shipped with HDD carrier) on any blank HDD carrier.

---

## 5. System Boards in the Node Tray

The Node tray includes mother board, node docking board, bridge board, and node fan set.

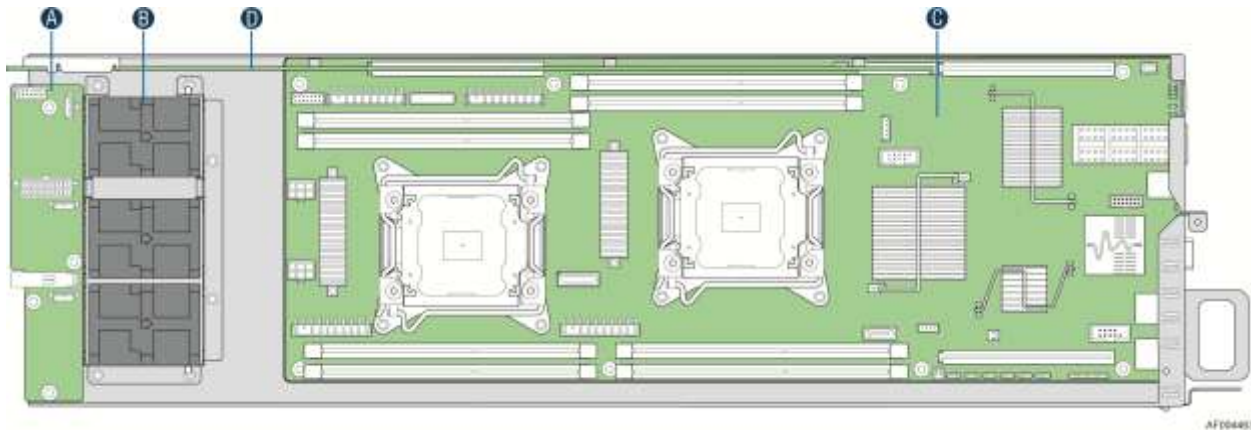

A	Node Docking Board
B	Node Fan Set
C	Baseboard
D	Bridge Board

Figure 22. Compute Node Tray Overview

### 5.1 Node Docking Board

#### 5.1.1 Overview of Node Docking Board

The Node Docking Board provides hot swap docking of 12V main power between the compute node and the server. It supports three dual rotor fan connections, 12V main power hot swap controller, and current sensing. The HW Power Docking Board is intended to support the usage of compute node of Intel® Server Board S2600JF family.

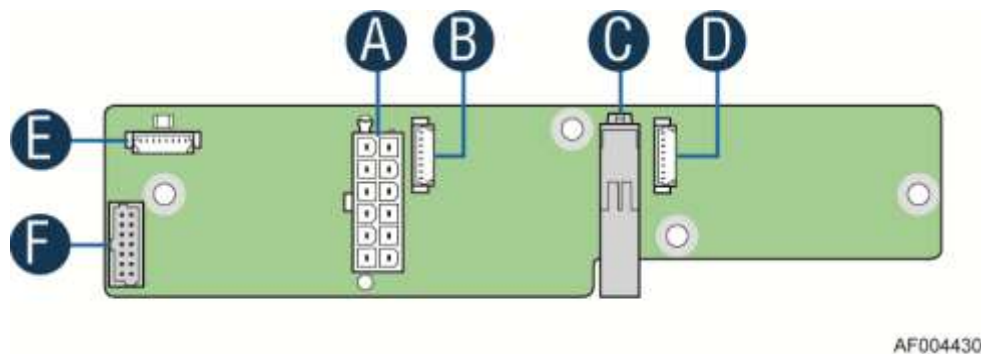

A	2x6 pin Minitit Jr main power output connector
B	8 pin connector for node fan 2
C	12 pin connector for main power input
D	8 pin connector for node fan 3
E	8 pin connector for node fan 1
F	2x7 pin fan control connector

Figure 23. Node Docking Board

The Node Docking Board implements the following features:

- Main 12V hot swap connectivity between compute node and chassis power.
- Current sensing of 12V main power for use with node manager.
- One 2x6pin mini-fit jr high current connectors for cabling either the HW baseboard or a double width add-in card in a customized chassis. Different cable lengths will be needed for the different depth HW baseboards.
- 2x7pin fan single connector, discrete cabled to the HW baseboard.
- Three 8-pin dual rotor fan connectors.
- Four loose screws used to secure board to the compute node.

### 5.1.2 Pin-out Definition on Node Docking Board

The table below lists the connector type and pin definition on Node Docking Board.

**Table 37. Main Power Input Connector**

Pin	Signal Description	Pin	Signal Description
Lower Blade (Circuit 1)			
1	GND	2	GND
3	GND	4	GND
5	GND	6	GND
Upper Blade (Circuit 2)			
7	P12V	8	P12V
9	P12V	10	P12V
11	P12V	12	P12V

**Table 38. Fan Control Signal Connector**

Pin	Signal Description	Pin	Signal Description
1	PWM1	2	Reserved
3	Tach0	4	Tach1
5	Tach2	6	Tach3
7	Tach4	8	Tach5
9	NODE_ON	10	GND
11	SMBUS_R4 CLK	12	SMBUS_R4 DAT
13	NODE_ADR0	14	NODE_PWRGD

**Table 39. Node Fan Connector**

Pin	Signal Description
1	GND
2	P12V
3	TACH1
4	PWM1
5	GND
6	P12V
7	TACH2
8	PWM1



**Table 40. Main Power Output Connector**

Pin	Signal Description	Pin	Signal Description
1	GND	7	P12V_HS
2	GND	8	P12V_HS
3	GND	9	P12V_HS
4	GND	10	P12V_HS
5	GND	11	P12V_HS
6	GND	12	P12V_HS

## 5.2 Bridge Board

There are several types of bridge boards that implement different features and functions when working with Intel® Server Board S2600JF family. This section describes the common bridge board which is shipping with H2000JF system.

### 5.2.1 Overview of Bridge Board

The bridge board is a common board across all baseboards going into the H2000JF serials server chassis. The bridge board provides hot swap interconnect of all electrical signals to the backplane of the server chassis (except for main 12V power). It supports up to 4x lanes of SAS/SATA, a 7-pin SATA connector for SATA DOM devices, and type-A USB connector for USB flash device. One bridge board is used per one compute node. The bridge board is secured with three loose screws to the compute node tray.

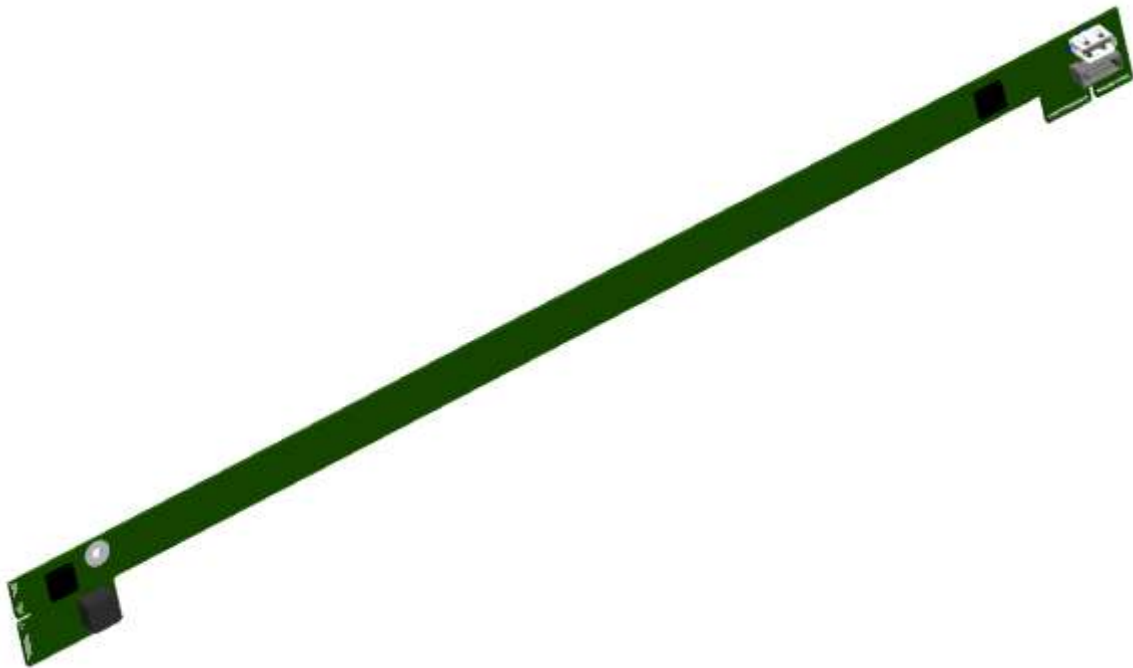
**Figure 24. Bridge Board Overview**

Bridge board passes all electrical connectivity through a 2x40pin card edge hot swap interconnect between compute node and chassis backplane. The bridge board passes the following features (per compute node) to the backplane of the server:

- 4x 6Gb SAS/SATA ports for HSBP drives
- Two x4 lane 6Gb SAS/SATA re-drivers
- Four chassis ID signals to determine the physical location of the compute node
- One SGPIO SFF-8485 interface to the HSBP microcontroller
- 5V\_AUX power generated on HSBP and provided to the compute node
- 3.3V power generated on HSBP and provided to bridge board to run SAS/SATA re-drivers
- Global PMBus\* alert signal for CLST support
- Four SMBus\* interfaces:
  - SMBUS\* R1: For chassis temp sensor and chassis FRU EEPROM device
  - SMBUS\* R5: Connectivity to up to two HSBP controllers and one shared .12V current monitoring device
  - SMBUS\* R7: Connectivity to up to two common redundant power supply (CRPS) module PMBus\*
  - IPMB: For OEM requirement not used on EPSD HW servers
  - Front panel button signals: Power, reset, NMI, and ID
  - Front panel LEDs signals: Power, fault, status, fabric activity, ID, HDD activity
- One 7-pin 6Gb SATA port connector for DOM device docking to the bridge board
- USB2.0 interface to a 4-pin type-A connector for flash device docking to bridge board
- 2-Pin 5V\_AUX power for the SATA DOM in need of cabling power

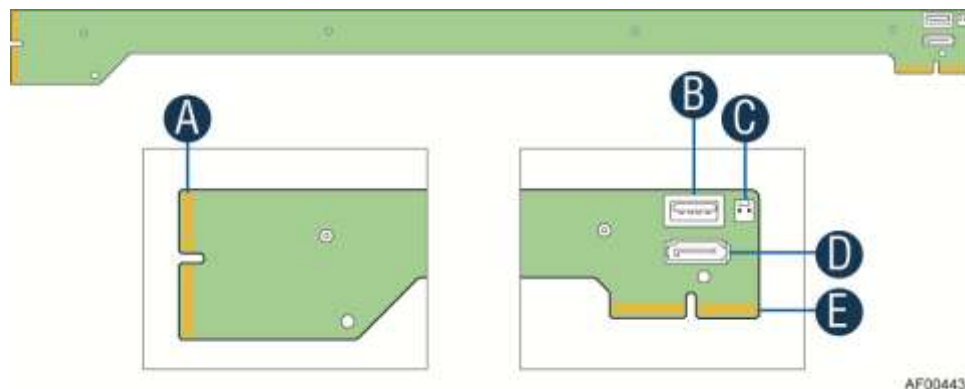

A	2x40 pin card edge connector (to backplane)
B	USB 2.0 Type-A connector
C	2-pin 5V_AUX power
D	AHCI SATA0 DOM port connector
E	2x40 pin card edge connector (to baseboard slot)

**Figure 25. Connectors on Bridge Board**

## 5.2.2 Pin-out Definition on Bridge Board

The table below lists the connector pin definition on the bridge board.

**Table 41. Card Edge Connector Pin-out**

Pin	Signal Description	Pin	Signal Description
1	5V Aux	2	5V Aux
3	SATA0_TXN	4	USB2_OC
5	SATA0_TXP	6	GND
7	GND	8	SATA0_RXN
9	NODE_PRESENT_N (GND)	10	SATA0_RXP
11	ALL_NODE_OFF	12	GND
13	spare	14	USB2_P0P
15	GND	16	USB2_P0N
17	IPMB-Data	18	GND
19	IPMB-Clk	20	FP HDD_ACT_LED_N
21	GND	22	FP Activity LED_N
23	SMBUS_R1 DATA	24	FP Health LEDA_N
25	SMBUS_R1 CLK	26	FP Health LEDG_N
27	GND	28	FP PWR LED_N
29	SMBUS_R5 DATA	30	FP ID LED_N
31	SMBUS_R5 CLK	32	FP ID BTN_N
33	GND	34	FP RST BTN_N
35	SMBUS_R7 DATA	36	FP PWR BTN_N
37	SMBUS_R7 CLK	38	FP NMI BTN_N
39	GND	40	SPA_SOUT_N
41	PMBUS Alert_N	42	SPA_SIN_N
43	NODEx_ON_N	44	ID3
45	SGPIO DATA IN	46	ID2
47	SGPIO Data Out	48	ID1
49	SGPIO LD	50	ID0
51	SPKR	52	SGPIO CLK
53	GND	54	GND
55	SAS3_RX	56	SAS3_TX
57	SAS3_RX	58	SAS3_TX
59	GND	60	GND
61	SAS2_TX	62	SAS2_RX
63	SAS2_TX	64	SAS2_RX
65	GND	66	GND
67	SAS1_RX	68	SAS1_TX
69	SAS1_RX	70	SAS1_TX
71	GND	72	GND
73	SAS0_TX	74	SAS0_RX
75	SAS0_TX	76	SAS0_RX
77	GND	78	GND
79	P3V3 (HSBP Side) and GND (HW Baseboard Side)	80	P3V3 (HSBP Side) and SATA_SAS_N (HW Baseboard Side)

The SATA DOM used on SATA0 port can be either powered by the SATA port, or using external power from 5V-AUX connector.

**Table 42. AHCI SATA0 DOM Connector Pin-out**

Pin	Signal Description
1	GND
2	SATA0_TXP
3	SATA0_TXN
4	GND
5	SATA0_RXN
6	SATA0_RXP
7	P5V_SATA/GND

**Table 43. USB 2.0 Type-A Connector Pin-out**

Pin	Signal Description
1	P5V_USB
2	USB2_P0N
3	USB2_P0P
4	GND

**Table 44. 5V\_AUX Power Connector Pin-out**

Pin	Signal Description
1	GND
2	P5V

## 5.3 6Gbs SAS Support Option 1

This bridge board is designed to support 6Gbs SAS signal from internal SAS RAID controller. This bridge board is not connect to SCU ports from baseboard but makes all other power and control signals available to backplane. It ships together with a dedicated SAS cable as a spare of the system.

### 5.3.1 Overview of Bridge Board

The bridge board is a spare board across all baseboards going into the H2000JF serials server chassis, to upgrade the system for 6Gbs SAS support. The bridge board provides hot swap interconnect of all electrical signals to the backplane of the server chassis (except for main 12V power). It supports up to 4x lanes of SAS/SATA and one mini SAS connector for cable connection to PCIe based RAID card or SAS ROC. One bridge board is used per one compute node. The bridge board is secured with several loose screws to the compute node tray.

A dedicated mini SAS cable is shipped together with the bridge board, which is mechanically fitted into the node tray.

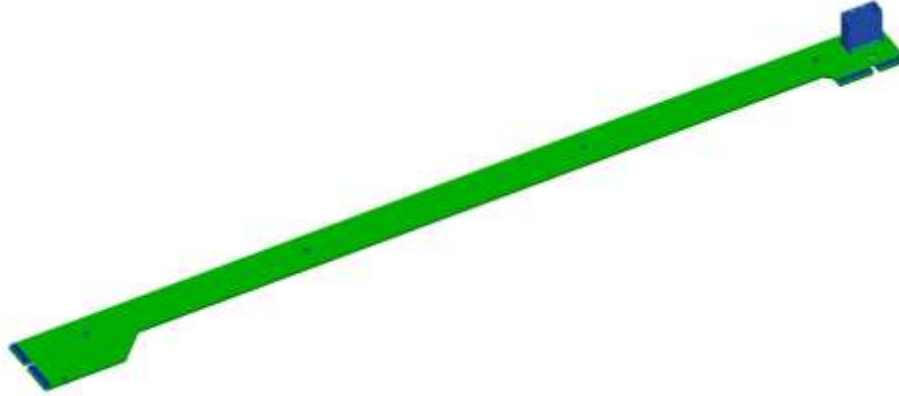

**Figure 26. SAS 6Gbps Bridge Board Overview**

This bridge board passes all electrical connectivity through a 2x40pin card edge hot swap interconnect between compute node/SAS RAID card and chassis backplane. The bridge board passes the follow features (per compute node) to the backplane of the server:

- 4x 6Gb SAS/SATA signals through Mini SAS port to HSBP drives
- Two x4 lane 6Gb SAS/SATA re-drivers
- Four chassis ID signals to determine the physical location of the compute node
- One SGPIO SFF-8485 interface to the HSBP microcontroller
- 5V\_AUX power generated on HSBP and provided to the compute node
- 3.3V power generated on HSBP and provided to bridge board to run SAS/SATA re-drivers
- Global PMBus\* alert signal for CLST support
- Four SMBus\* interfaces:
  - SMBus\* R1: For chassis temp sensor and chassis FRU EEPROM device
  - SMBus\* R5: Connectivity to up to two HSBP controllers and one shared .12V current monitoring device
  - SMBus\* R7: Connectivity to up to two common redundant power supply (CRPS) module PMBus\*
  - IPMB: For OEM requirement not used on EPSD HW servers
  - Front panel button signals: Power, reset, NMI, and ID
  - Front panel LEDs signals: Power, fault, status, fabric activity, ID, and HDD activity

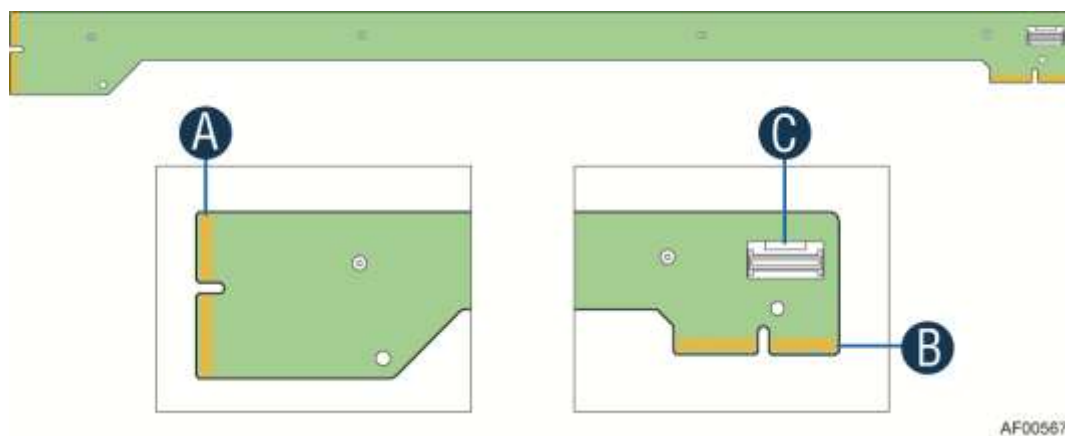

<b>A</b>	2x40 pin card edge connector (to backplane)
<b>B</b>	2x40 pin card edge connector (to baseboard bridge slot)
<b>C</b>	4-port Mini SAS Connector

**Figure 27. Connectors and Components on Spare Bridge Board**

### 5.3.2 Pin-out Definition on SAS 6Gbs Bridge Board

The table below lists the connector pin definition on the bridge board.

**Table 45. Pin-out of Card Edge to Base Board**

Pin	Signal Name	Pin	Signal Name	Pin	Signal Name	Pin	Signal Name
1	5V_AUX	2	5V_AUX	41	PMBUS_ALERT_N	42	SPA_SIN
3	N/C	4	USB2_OC	43	NODE_ON_N	44	IBMC_NODEID_3
5	N/C	6	GND	45	SGPIO_DATA_IN	46	IBMC_NODEID_2
7	GND	8	N/C	47	SGPIO_DATA_OUT	48	IBMC_NODEID_1
9	NODE_PRESENT_N	10	N/C	49	SGPIO_LOAD	50	IBMC_NODEID_0
11	ALL_NODE_OFF	12	GND	51	SPEAKER_IN	52	N/C
13	N/C	14	N/C	53	GND	54	GND
15	GND	16	N/C	55	N/C	56	N/C
17	IPMB_DATA	18	GND	57	N/C	58	N/C
19	IPMB_CLK	20	LED_HDD_ACT_N	59	GND	60	GND
21	GND	22	FP_ACT_LED_N	61	N/C	62	N/C
23	SMB_SNSR_DATA	24	FP_LED_STSA_N	63	N/C	64	N/C
25	SMB_SNSR_CLK	26	FP_LED_STSG_N	65	GND	66	GND
27	GND	28	FP_PWR_LED_N	67	N/C	68	N/C
29	SMB_HSBP_DATA	30	FP_ID_LED_N	69	N/C	70	N/C
31	SMB_HSBP_CLK	32	FP_ID_BTN_N	71	GND	72	GND
33	GND	34	FP_RST_BTN_N	73	N/C	74	N/C
35	SMB_PMBUS_DATA	36	FP_PWR_BTN_N	75	N/C	76	N/C
37	SMB_PMBUS_CLK	38	FP_NMI_BTN_N	77	GND	78	GND
39	GND	40	SPA_SOUT	79	GND	80	SAS_SATA_SET_N

Table 46. Pin-out of Card Edge to Hot Swap Back Plane

Pin	Signal Name	Pin	Signal Name	Pin	Signal Name	Pin	Signal Name
1	5V_AUX	2	5V_AUX	41	PMBUS_ALERT_N	42	SPA_SIN
3	N/C	4	N/C	43	NODE_ON_N	44	IBMC_NODEID_3
5	N/C	6	GND	45	SGPIO_DATA_IN	46	IBMC_NODEID_2
7	GND	8	N/C	47	SGPIO_DATA_OUT	48	IBMC_NODEID_1
9	NODE_PRESENT_N	10	N/C	49	SGPIO_LOAD	50	IBMC_NODEID_0
11	ALL_NODE_OFF	12	GND	51	SPEAKER_IN	52	SGPIO_CLOCK
13	3V3_AUX	14	N/C	53	GND	54	GND
15	GND	16	N/C	55	SAS3_RX_BP_N	56	SAS3_TX_BP_N
17	IPMB_DATA	18	GND	57	SAS3_RX_BP_P	58	SAS3_TX_BP_P
19	IPMB_CLK	20	LED_HDD_ACT_N	59	GND	60	GND
21	GND	22	FP_ACT_LED_N	61	SAS2_TX_BP_N	62	SAS2_RX_BP_N
23	SMB_R1_DATA	24	FP_LED_STSA_N	63	SAS2_TX_BP_P	64	SAS2_RX_BP_P
25	SMB_R1_CLK	26	FP_LED_STSG_N	65	GND	66	GND
27	GND	28	FP_PWR_LED_N	67	SAS1_RX_BP_N	68	SAS1_TX_BP_N
29	SMB_HSBP_DATA	30	FP_ID_LED_N	69	SAS1_RX_BP_P	70	SAS1_TX_BP_P
31	SMB_HSBP_CLK	32	FP_ID_BTN_R_N	71	GND	72	GND
33	GND	34	FP_RST_BTN_N	73	SAS0_TX_BP_N	74	SAS0_RX_BP_N
35	SMB_PMBUS_DATA	36	FP_PWR_BTN_N	75	SAS0_TX_BP_P	76	SAS0_RX_BP_P
37	SMB_PMBUS_CLK	38	FP_NMI_BTN_N	77	GND	78	GND
39	GND	40	SPA_SOUT	79	3V3	80	3V3

Table 47. Pin-out of Mini SAS Connector

Pin	Signal Name	Pin	Signal Name	Pin	Signal Name	Pin	Signal Name
A1	GND	A10	GND	B1	GND	B10	SGPIO_DATA_OUT
A2	SAS0_TX_P	A11	N/C	B2	SAS0_RX_P	B11	SGPIO_DATA_IN
A3	SAS0_TX_N	A12	GND	B3	SAS0_RX_N	B12	GND
A4	GND	A13	SAS2_TX_P	B4	GND	B13	SAS2_RX_P
A5	SAS1_TX_P	A14	SAS2_TX_N	B5	SAS1_RX_P	B14	SAS2_RX_N
A6	SAS1_TX_N	A15	GND	B6	SAS1_RX_N	B15	GND
A7	GND	A16	SAS3_TX_P	B7	GND	B16	SAS3_RX_P
A8	SGPIO_CLOCK	A17	SAS3_TX_N	B8	SAS_BP_TYPE	B17	SAS3_RX_N
A9	SGPIO_LOAD	A18	GND	B9	N/C	B18	GND

## 5.4 6Gbs SAS Support Option 2

The dedicated 6Gbs SAS controller RMS25LB040 is designed for Intel® Server System H2000JF, together with dedicated bridge board and riser card as total solution kit. This solution leaves the PCIe slot 1 available for additional LP PCIe base add-in card.

The solution kit includes three major parts: bridge board, riser card, and SAS controller module.

### 5.4.1 Bridge Board

The bridge board in the solution kit is shown below. The original bridge board in the base system must be replaced with this bridge board in order to install the rest riser card and SAS controller module.

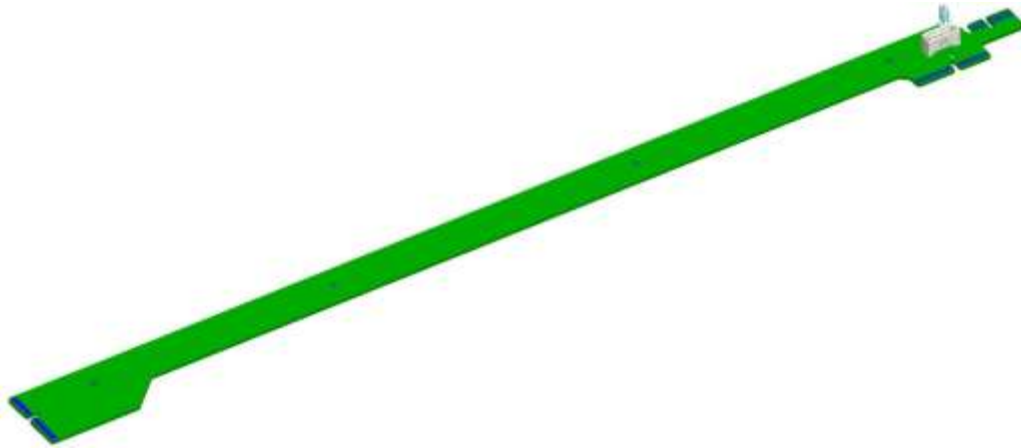

**Figure 28. Overview of the Bridge Board**

Main connectors on the bridge board are defined as follows.

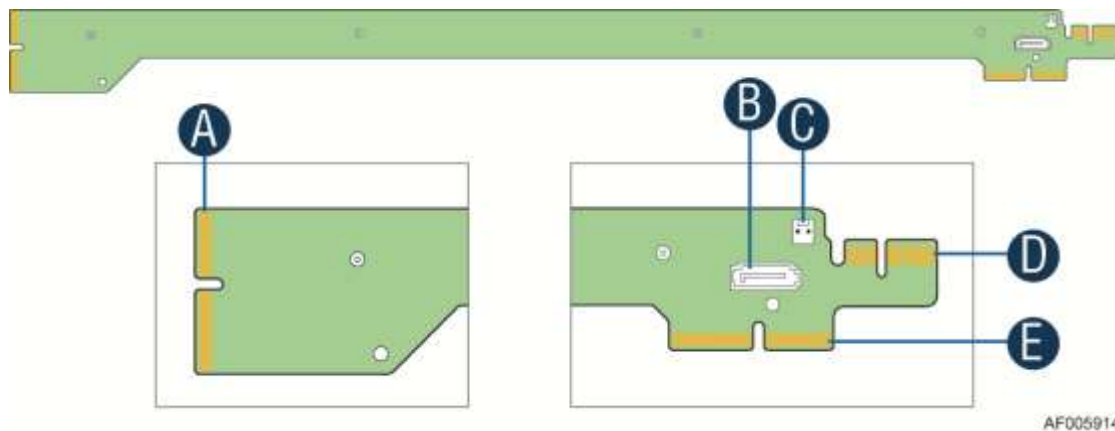

AF005914

<b>A</b>	2x40 pin card edge connector (to backplane)
<b>B</b>	SATA DOM Connector
<b>C</b>	Auxiliary SATA DOM Power
<b>D</b>	2x18 pin card edge connector (to SAS Controller)
<b>E</b>	2x40 pin card edge connector ( to bridge slot on baseboard)

**Figure 29. Connectors on Bridge Board**

The pin-out of card edge to Hot Swap Backplane is the same as defined in



Table 46, and pin-out of card edge to bridge board slot is the same as defined in Table 45. The pin-out of card edge to SAS controller module is defined below.

**Table 48. Card Edge Pin-out of Bridge Board to SAS Controller**

Pin	Signal Name	Pin	Signal Name	Pin	Signal Name	Pin	Signal Name
A1	NC	B1	GND	A10	SAS2_RX_P	B10	SAS2_TX_N
A2	SGPIO_LOAD	B2	SGPIO_DATA_IN	A11	GND	B11	GND
A3	SGPIO_CLOCK	B3	SGPIO_DATA_OUT	A12	SAS1_TX_N	B12	SAS1_RX_P
A4	GND	B4	GND	A13	SAS1_TX_P	B13	SAS1_RX_N
A5	SAS3_TX_N	B5	SAS3_RX_P	A14	GND	B14	GND
A6	SAS3_TX_P	B6	SAS3_RX_N	A15	GND	B15	SAS0_TX_P
A7	GND	B7	GND	A16	SAS0_RX_N	B16	SAS0_TX_N
A8	GND	B8	GND	A17	SAS0_RX_P	B17	GND
A9	SAS2_RX_N	B9	SAS2_TX_P	A18	GND	B18	NC

Pin definition for SATA DOM and Auxiliary Power connectors are the same as defined in Table 42 and Table 44.

## 5.4.2 Riser Card

The riser card provides electrical connectivity for installing a standard PCIe x8 Gen3 low profile form factor adapter card. It supports a PCIe Gen3 x8 card edge connection, and for passing an RGMII interface across to SAS Module. The riser card is secured with two loose screws to the compute node sheet metal bracket.

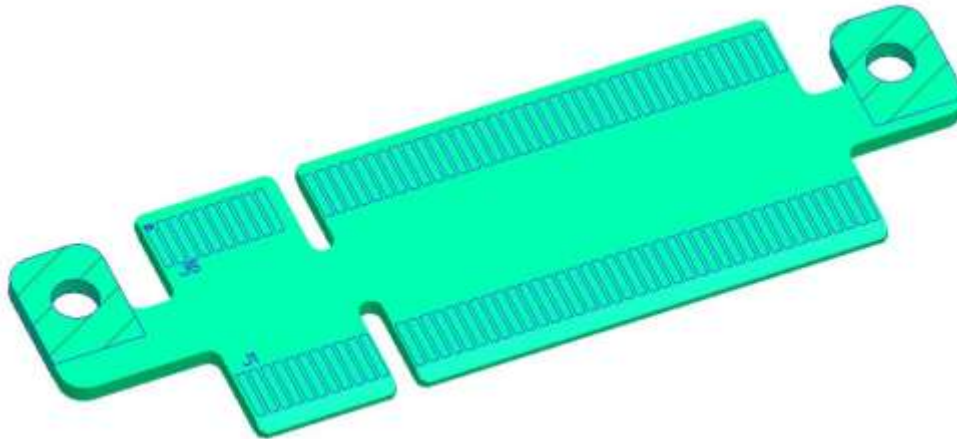

**Figure 30. Overview of the Riser Card**

Riser card pin-out definition is as follows.

**Table 49. Card Edge Pin-out of Riser Card to SAS Controller**

Pin	Signal Name	Pin	Signal Name	Pin	Signal Name	Pin	Signal Name
A1	P12V	B1	P3V3_1	A26	P3E_RX_DP< 5>	B26	GND

Pin	Signal Name	Pin	Signal Name	Pin	Signal Name	Pin	Signal Name
A2	P12V	B2	P3V3_2	A27	P3E_RX_DN<5>	B27	GND
A3	P12V	B3	P3V3_3	A28	GND	B28	P3E_TX_C_D P<5>
A4	P12V	B4	SMB_DAT_P3E_P3V3_AUX	A29	GND	B29	P3E_TX_C_D N<5>
A5	SMB_CLK_P3E_P3V3_AUX	B5	P5V_STBY	A30	P3E_RX_DP<4>	B30	GND
A6	P3V3_AUX	B6	PD_P3E_PRSNT_N	A31	P3E_RX_DN<4>	B31	GND
A7	GND	B7	LED_HDD_ACT_N	A32	GND	B32	P3E_TX_C_D P<4>
A8	RGMII_IBMC_RMM4_TXD_0	B8	RGMII_IBMC_RMM4_RXD_3	A33	GND	B33	P3E_TX_C_D N<4>
A9	RGMII_IBMC_RMM4_TXD_1	B9	RGMII_IBMC_RMM4_RXD_2	A34	P3E_RX_DP<3>	B34	GND
A10	RGMII_IBMC_RMM4_TXD_2	B10	RGMII_IBMC_RMM4_RXD_1	A35	P3E_RX_DN<3>	B35	GND
A11	RGMII_IBMC_RMM4_TXD_3	B11	RGMII_IBMC_RMM4_RXD_0	A36	GND	B36	P3E_TX_C_D P<3>
A12	GND	B12	RGMII_IBMC_RMM4_RX_CTRL	A37	GND	B37	P3E_TX_C_D N<3>
A13	RGMII_IBMC_RMM4_TX_CLK	B13	GND	A38	P3E_RX_DP<2>	B38	GND
A14	RGMII_IBMC_RMM4_TX_CTRL	B14	RGMII_IBMC_RMM4_RX_CLK	A39	P3E_RX_DN<2>	B39	GND
A15	RGMII_IBMC_RMM4_MDIO	B15	RGMII_IBMC_RMM4_MDC	A40	GND	B40	P3E_TX_C_D P<2>
A16	RST_P3E_N	B16	GND	A41	GND	B41	P3E_TX_C_D N<2>
A17	TP_IRQ_LVC3_WAKE_N	B17	CLK_100M_P3E_REF_DP	A42	P3E_RX_DP<1>	B42	GND
A18	P3E_RX_DP<7>	B18	CLK_100M_P3E_REF_DN	A43	P3E_RX_DN<1>	B43	GND
A19	P3E_RX_DN<7>	B19	GND	A44	GND	B44	P3E_TX_C_D P<1>
A20	GND	B20	P3E_TX_C_DP<7>	A45	GND	B45	P3E_TX_C_D N<1>
A21	GND	B21	P3E_TX_C_DN<7>	A46	P3E_RX_DP<0>	B46	GND
A22	P3E_RX_DP<6>	B22	GND	A47	P3E_RX_DN<0>	B47	GND
A23	P3E_RX_DN<6>	B23	GND	A48	GND	B48	P3E_TX_C_D P<0>
A24	GND	B24	P3E_TX_C_DP<6>	A49	GND	B49	P3E_TX_C_D N<0>
A25	GND	B25	P3E_TX_C_DN<6>				

Table 50. Card Edge Pin-out of Riser Card to PCIe Slot2 of Baseboard

Pin	Signal Name	Pin	Signal Name	Pin	Signal Name	Pin	Signal Name
B1	P12V	A1	P3V3_1	B26	P3E_RX_DP<5>	A26	GND
B2	P12V	A2	P3V3_2	B27	P3E_RX_DN<5>	A27	GND

Pin	Signal Name	Pin	Signal Name	Pin	Signal Name	Pin	Signal Name
B3	P12V	A3	P3V3_3	B28	GND	A28	P3E_TX_C_D P<5>
B4	P12V	A4	SMB_DAT_P3E_P3V3_AUX	B29	GND	A29	P3E_TX_C_D N<5>
B5	SMB_CLK_P3E_P3V3_AUX	A5	P5V_STBY	B30	P3E_RX_DP<4>	A30	GND
B6	P3V3_AUX	A6	PD_P3E_PRSNNT_N	B31	P3E_RX_DN<4>	A31	GND
B7	GND	A7	LED_HDD_ACT_N	B32	GND	A32	P3E_TX_C_D P<4>
B8	RGMII_IBMC_RMM4_TXD_0	A8	RGMII_IBMC_RMM4_RXD_3	B33	GND	A33	P3E_TX_C_D N<4>
B9	RGMII_IBMC_RMM4_TXD_1	A9	RGMII_IBMC_RMM4_RXD_2	B34	P3E_RX_DP<3>	A34	GND
B10	RGMII_IBMC_RMM4_TXD_2	A10	RGMII_IBMC_RMM4_RXD_1	B35	P3E_RX_DN<3>	A35	GND
B11	RGMII_IBMC_RMM4_TXD_3	A11	RGMII_IBMC_RMM4_RXD_0	B36	GND	A36	P3E_TX_C_D P<3>
B12	GND	A12	RGMII_IBMC_RMM4_RX_CTRL	B37	GND	A37	P3E_TX_C_D N<3>
B13	RGMII_IBMC_RMM4_TX_CLK	A13	GND	B38	P3E_RX_DP<2>	A38	GND
B14	RGMII_IBMC_RMM4_TX_CTRL	A14	RGMII_IBMC_RMM4_RX_CLK	B39	P3E_RX_DN<2>	A39	GND
B15	RGMII_IBMC_RMM4_MDIO	A15	RGMII_IBMC_RMM4_MDC	B40	GND	A40	P3E_TX_C_D P<2>
B16	RST_P3E_N	A16	GND	B41	GND	A41	P3E_TX_C_D N<2>
B17	TP_IRQ_LVC3_WAKE_N	A17	CLK_100M_P3E_REF_DP	B42	P3E_RX_DP<1>	A42	GND
B18	P3E_RX_DP<7>	A18	CLK_100M_P3E_REF_DN	B43	P3E_RX_DN<1>	A43	GND
B19	P3E_RX_DN<7>	A19	GND	B44	GND	A44	P3E_TX_C_D P<1>
B20	GND	A20	P3E_TX_C_DP<7>	B45	GND	A45	P3E_TX_C_D N<1>
B21	GND	A21	P3E_TX_C_DN<7>	B46	P3E_RX_DP<0>	A46	GND
B22	P3E_RX_DP<6>	A22	GND	B47	P3E_RX_DN<0>	A47	GND
B23	P3E_RX_DN<6>	A23	GND	B48	GND	A48	P3E_TX_C_D P<0>
B24	GND	A24	P3E_TX_C_DP<6>	B49	GND	A49	P3E_TX_C_D N<0>
B25	GND	A25	P3E_TX_C_DN<6>				

### 5.4.3 SAS Controller Module

The SAS Module uses the LSI\* 2308 host controller, totally generating up to 8ports of 6Gb SAS/SATA. SAS Module consists of a 1GbE PHY device RTL8211D which offers a dedicated management RJ45 1GbE port.

6Gb SAS Controller Module Key features:

1. LSI\* 2308 SAS controller supporting up to eight 6Gb SAS/SATA ports

2. Up to x8 lanes of PCIe Gen3 allowing up to 8Gb/s per direction
3. 16MBytes Flash ROM memory
4. 32kByte MRAM memory for write journaling support
5. 150MHz core clock
6. 1.0V core & 1.0V analog VRs, and 1.8V VR
7. Up to two universal keyed 36pin Mini-SAS connectors
8. Up to two SFF-8485 SGPIOs (SFF-8448 complaint sideband signals on each mini-SAS connector)
9. "Heart beat" & system error status LEDs
10. 8kByte Bootstrap EEPROM
11. 256Byte chassis FRU EEPROM (unstuffed) & TMP75 temp sensor (stuffed)
12. One UART Debug headers
13. A dedicated RJ45 connector & PHY with 1Gb RGMII interface

SAS Controller Module Key Components are listed below.

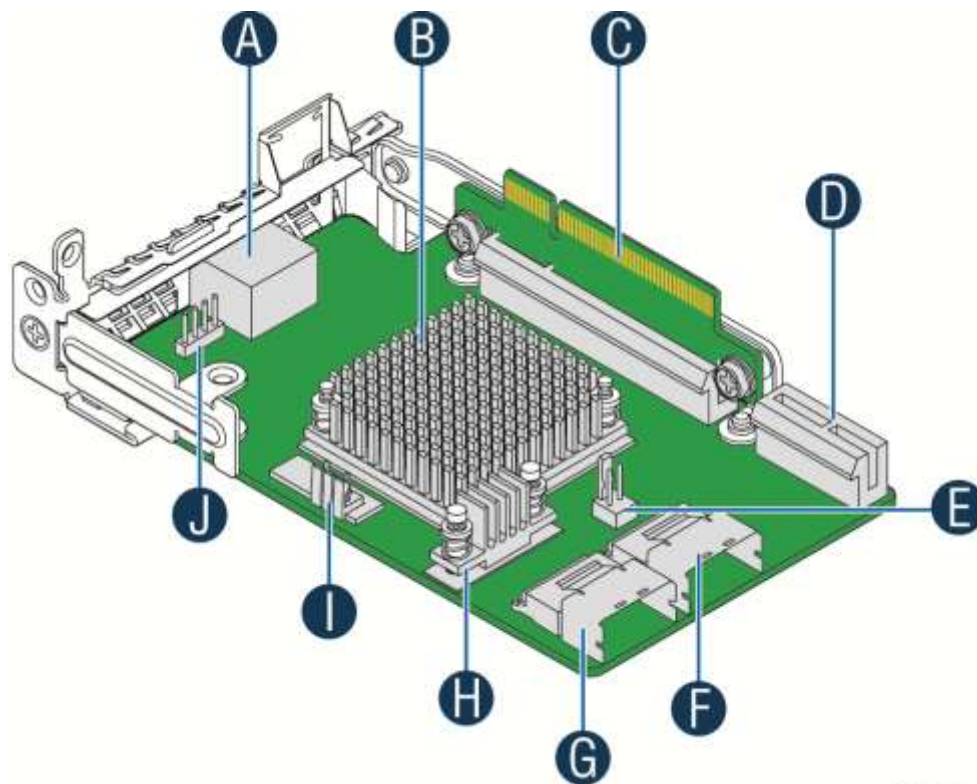

AF005913

<b>A</b>	RJ45 connector for 1GbE RGMII
<b>B</b>	LSI* 2308 SAS Controller
<b>C</b>	Riser Slot (with riser card installed)
<b>D</b>	Bridge Board Slot
<b>E</b>	HDD LED ACT Header
<b>F</b>	Mini SAS Connector 1 (Depop)
<b>G</b>	Mini SAS Connector 2 (Depop)
<b>H</b>	Voltage Regulator
<b>I</b>	RAID Key Header (Depop)
<b>J</b>	UART Debug Header

**Figure 31. SAS Controller Module Overview**

## 6. Hard Disk Drive Support

The server system provides two SKUs to support different types of Hard Disk Drives (HDD):

- H2312JF: Supports 12x 3.5" HDD
- H2216JF: Supports 16x 2.5" HDD

### 6.1 Hard Disk Drive Bays Scheme

The server system H2000 chassis can support up to 12 carrier-mounted SATA/SAS 3.5-inch hard disk drives, or 16 carrier-mounted SATA/SAS 2.5-inch hard disk drives. The drives may be “electrically” hot-swapped while the system power is applied, but you must take caution before hot-swapping while the system is functioning under operating system/application control or data may be lost.

Following are hard disk drive distribution schemes on different SKUs of H2000 chassis family.

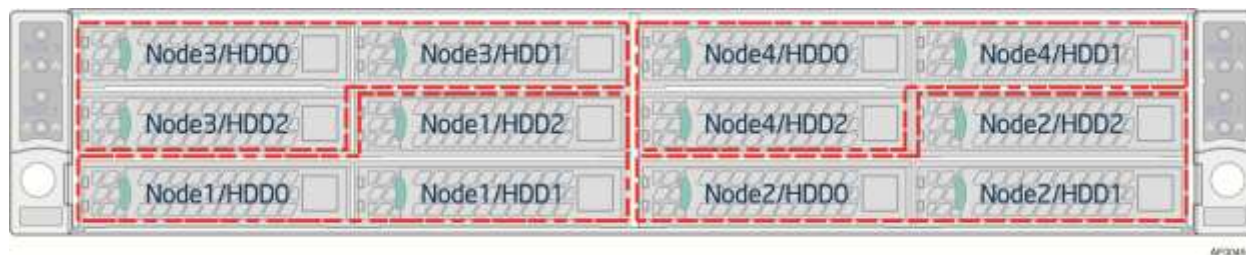

Figure 32. HDD Scheme for H2312JF

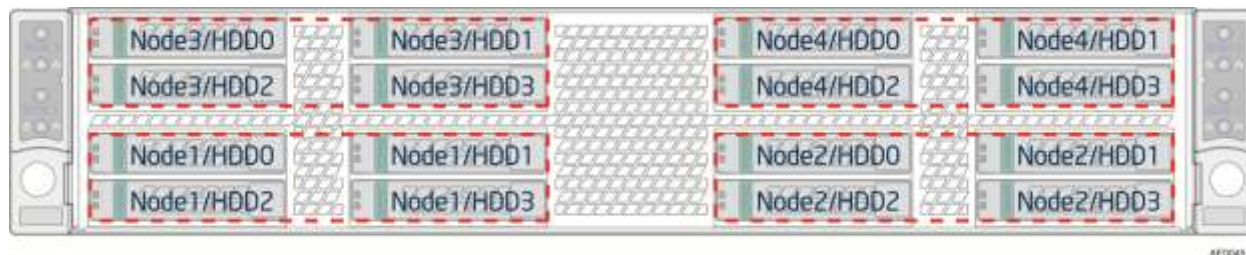
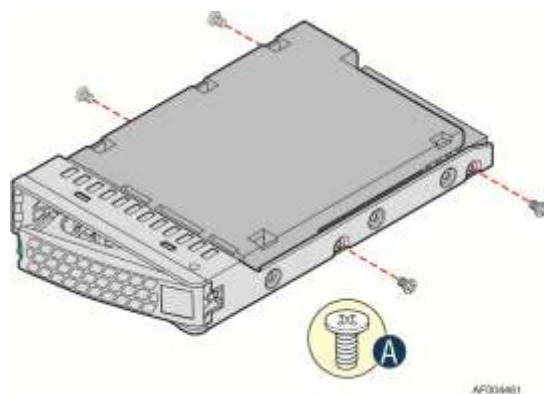

Figure 33. HDD Scheme for H2216JF

**Note:** If a failed drive needs to be replaced, it is recommended you replace it with the same manufacturer, model, and capacity.

### 6.2 Hard Drive Carrier

There are two types of HDD carriers for two chassis SKUs respectively.



**Figure 34. 3.5-inch HDD Assembly Overview**

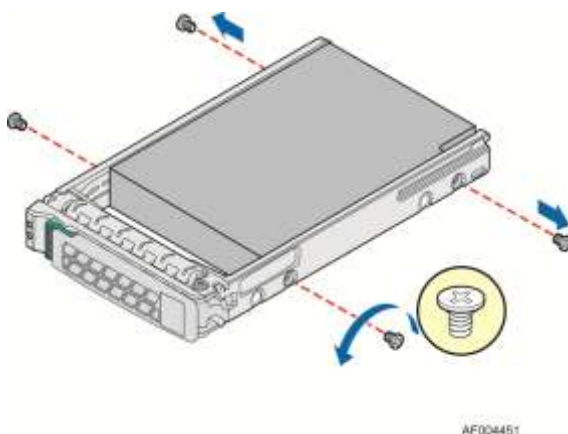

**Figure 35. 2.5-inch HDD Assembly Overview**

Hot-swap drive carriers make insertion and extraction of the drive from the system very simple. Each type of drive carrier has its own latching mechanism, which is used to both insert and extract drives from the chassis and lock the carrier in place. Each type of drive carrier supports two light pipes to direct light from the drive status LEDs on the backplane to the carrier's face allowing it to be viewable from the front of the system.

### 6.3 Hot-Swap Hard Drive Support

Both the Intel® Server System H2312JF and H2216JF can support hot-swap SATA/SAS hard drives. Hard drives interface with the passive backplane through a blind mate connection when drives are installed into a hard drive bay using hot-swap drive carriers.

The passive backplane acts as an intermediate pass-through interface board where SATA/SAS ports of SCU0 from server board are hard wired to the backplane. The on board Intel® C600 Chipset (PCH) provides the necessary drive interface.

Each compute node in the system has dedicated Hot Swap Controller (HSC) to manage three or four HDDs. There are totally four sets of independent Programmable System On Chip (PSOC) on the backplane to function as HSC respectively to the four compute nodes.

The following sections describe the feature and connections between the backplane and server board.

### 6.3.1 Backplane Feature Set

- Common HSBP Microcontroller Cypress\* PSoC 1 part.
- **H2312JF**: 12x SAS/SATA 3.5" HDDs at 6Gb/s SAS/SATA or slower speeds, divided into 4 groups of three hot swap hard drives. Each HDD group is associated with one of the four compute nodes respectively in the 2U chassis.
- **H2216JF**: 16x SAS/SATA 2.5" HDDs at 6Gb/s SAS/SATA or slower speeds, divided into 4 groups of four hot swap hard drives. Each HDD group is associated with one of the four compute nodes respectively in the 2U chassis.
- One SGPIO SFF-8485 interface per compute node, total of four SGPIO on the backplane.
- Three SMBus\* interfaces supported on the HSBP:
  - SMBus\* R1: For chassis temp sensor and chassis FRU EEPROM device.
  - SMBus\* R5: Connectivity to up to two HSBP controllers and one shared 12V current monitoring device.
  - SMBus\* R7: Connectivity to up to two common redundant power supply (CRPS) module PMBus\*.
- Integrated front panel control connectors.
- Status LED and Activity LED for each hard disk drive.
- 5V\_AUX switcher regulator (from 12V and 12VSB) for HDD power and for compute nodes.
- Each grouping of HDD slots has switches for 5V and 12V power, only when corresponding compute node is plugged in and operating will power be provided to the HDDs.
- 3.3V switcher regulator (from 12V) to power microcontroller, SAS/SATA re-drivers on the bridge board and various other components.
- 3.3V\_AUX linear regulator (from 5V\_AUX) for temp sensor, and chassis FRU EEPROM located on the HSBP.
- Four 80-pin bridge board connectors, one per compute node.
- Four compute node main power connectors, one per compute node.
- Four 2x9pin power cable connections and one 2x9pin power control cable connections. These cables are routing to two power distribution boards (PDB).
- Shared speaker for all compute nodes.

### 6.3.2 Backplane Block Diagram

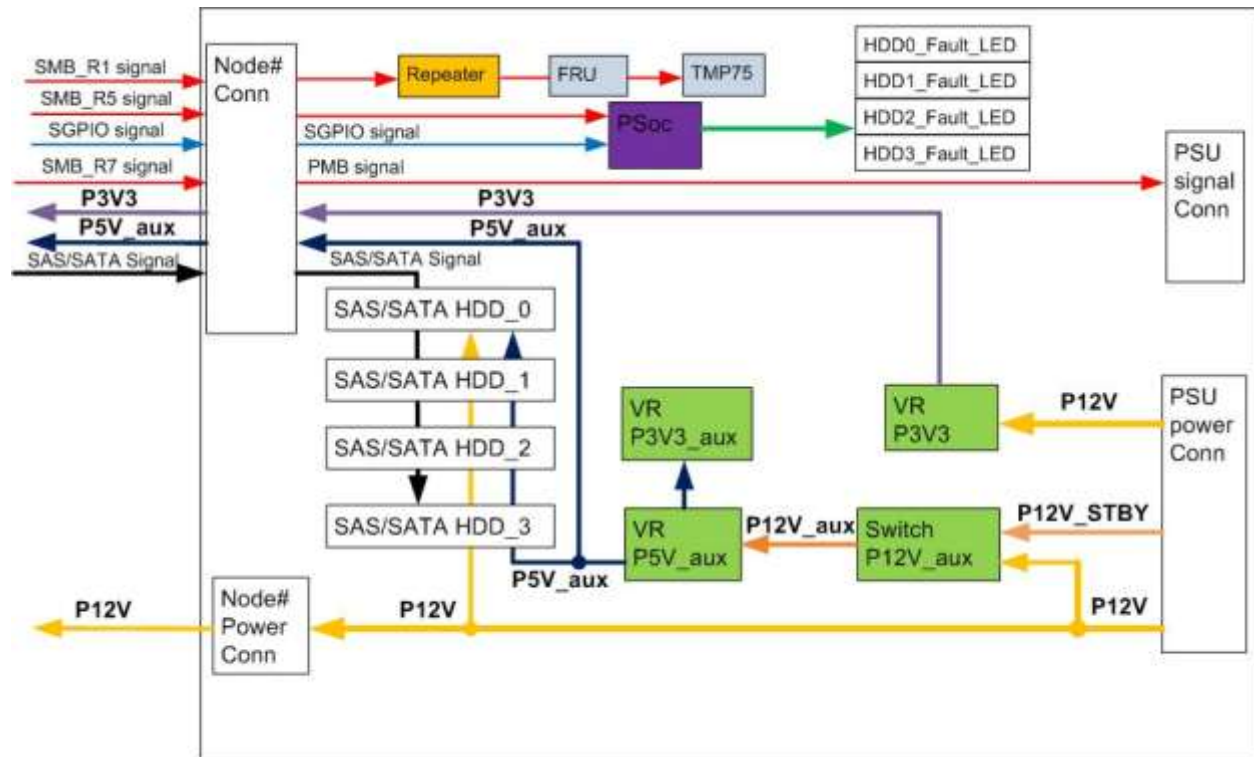
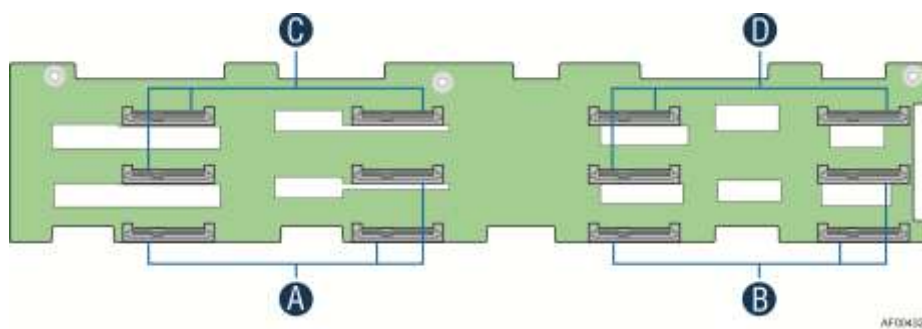

Figure 36. Passive Backplane Block Diagram (for One Node)

### 6.3.3 3.5" Hot Swap Backplane Connector Scheme

The following diagrams show the layout of major components and connectors for 3.5" Hot Swap backplane.



<b>A</b>	SATA/SAS connectors for Node 1
<b>B</b>	SATA/SAS connectors for Node 2
<b>C</b>	SATA/SAS connectors for Node 3
<b>D</b>	SATA/SAS connectors for Node 4

Figure 37. 3.5" Backplane Component and Connectors (Front View)



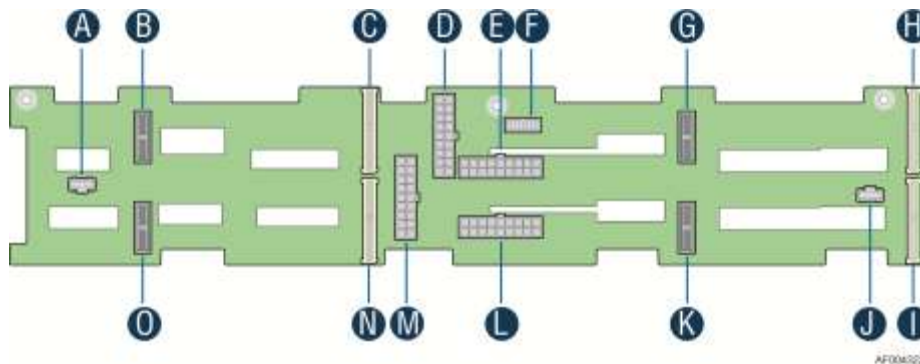

A	20-pin Front Panel cable connector for Node 2, 4
B	2-Blade Compute Node Power connector for Node 4
C	2x40 pin Bridge Board connector for Node 4
D	2x9 pin Power supply input connector
E	2x9 pin Power supply input connector
F	2x7 pin Power Control cable connector
G	2-Blade Compute Node Power connector for Node 3
H	2x40 pin Bridge Board connector for Node 3
I	2x40 pin Bridge Board connector for Node 1
J	20-pin Front Panel cable connector for Node 1, 3
K	2-Blade Compute Node Power connector for Node 1
L	2x9 pin Power supply input connector
M	2x9 pin Power supply input connector
N	2x40 pin Bridge Board connector for Node 2
O	2-Blade Compute Node Power connector for Node 2

Figure 38. 3.5" Backplane Component and Connectors (Back View)

### 6.3.4 2.5" Hot Swap Backplane Connector Scheme

The following diagrams show the layout of major components and connectors for 2.5" Hot Swap backplane.

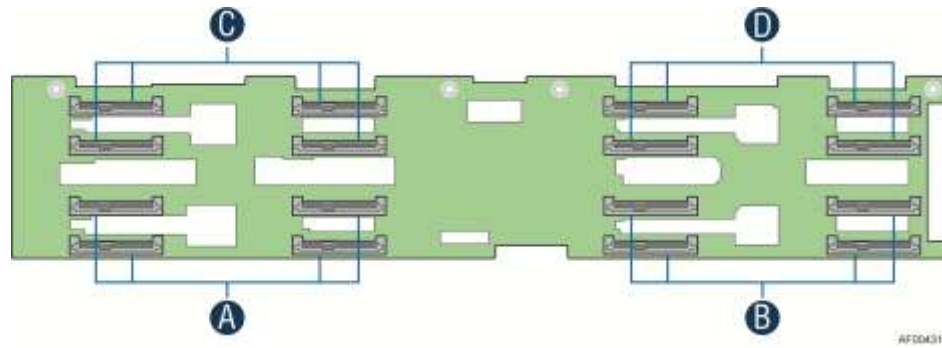

<b>A</b>	SATA/SAS connectors for Node 1
<b>B</b>	SATA/SAS connectors for Node 2
<b>C</b>	SATA/SAS connectors for Node 3
<b>D</b>	SATA/SAS connectors for Node 4

**Figure 39. 2.5" Backplane Component and Connectors (Front View)**

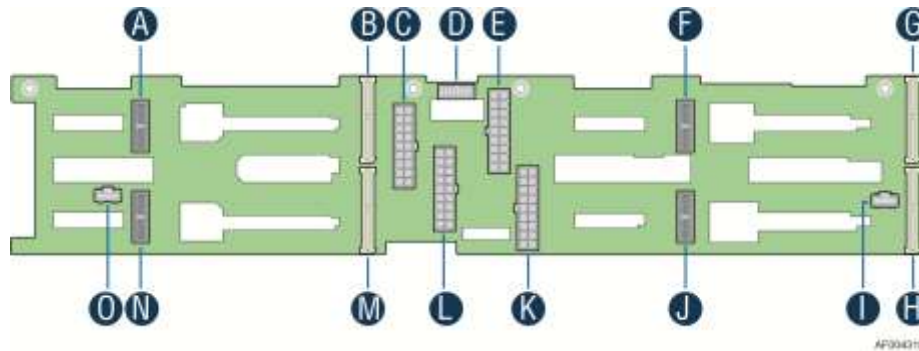

<b>A</b>	2-Blade Compute Node Power connector for Node 4
<b>B</b>	2x40 pin Bridge Board connector for Node 4
<b>C</b>	2x9 pin Power supply input connector
<b>D</b>	2x7 pin Power Control cable connector
<b>E</b>	2x9 pin Power supply input connector
<b>F</b>	2-Blade Compute Node Power connector for Node 3
<b>G</b>	2x40 pin Bridge Board connector for Node 3
<b>H</b>	2x40 pin Bridge Board connector for Node 1
<b>I</b>	20-pin Front Panel cable connector for Node 1, 3
<b>J</b>	2-Blade Compute Node Power connector for Node 1
<b>K</b>	2x9 pin Power supply input connector
<b>L</b>	2x9 pin Power supply input connector
<b>M</b>	2x40 pin Bridge Board connector for Node 2
<b>N</b>	2-Blade Compute Node Power connector for Node 2
<b>O</b>	20-pin Front Panel cable connector for Node 2, 4

**Figure 40. 2.5" Backplane Component and Connectors (Back View)**

### 6.3.5 Backplane LED Support

The backplanes support both HDD online and activity/fault LEDs for each of the hard drive connectors. A light duct in HDD tray is used to conduct LED light to front panel. The following lists LED functionality.

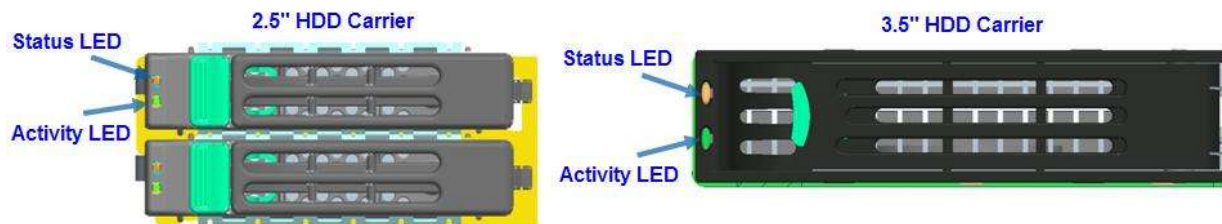

Figure 41. Hard Drive Carrier LED

General HDD LED functionality is displayed below.

Table 51. Hard Drive Carrier Status LED Functions

<b>Amber</b>	Off	No access and no fault
	Solid On	Hard Drive Fault has occurred
	Blink	Raid rebuild in progress (1hz) Identify (2hz)

Table 52. Hard Drive Carrier Activity LED Functions

	Condition	Drive Type	Behavior
<b>Green</b>	Power on with no drive activity	SAS	LED stays on.
		SATA	LED stays off.
	Power on with drive activity	SAS	LED blinks off when processing a command.
		SATA	LED blinks off when processing a command.
	Power on and drive spinning down	SAS	LED stays off.
		SATA	LED stays off.
	Power on and drive spinning up	SAS	LED blinks.
		SATA	LED stays off.

### 6.3.6 Backplane Connector Definition

The backplanes include several different connectors. This section defines the purpose and pin-out associated with each.

#### 1. 2x9 Pin Power Input Connector

The backplane is powered by +12V and +12V<sub>STB</sub> from PDB of CRPS. The input power is distributed by backplane to all four nodes.

**Table 53. Backplane Input Power Connector Pin-out**

Pin	Signal Description	Pin	Signal Description
2	P12V	1	GND
4	P12V	3	GND
6	P12V	5	GND
8	P12V	7	GND
10	P12V	9	GND
12	P12V	11	GND
14	P12V	13	GND
16	P12V	15	GND
18	P12V	17	GND

## 2. 2-Blade Compute Node Power Connector

The backplane provides main power to compute node through 2-Blade power connector.

**Table 54. 2-Blade Compute Node Power Connector Pin-out**

Pin	Signal Description	Pin	Signal Description
Lower Blade (Circuit 1)			
1	GND	2	GND
3	GND	4	GND
5	GND	6	GND
7	GND	8	GND
Upper Blade (Circuit 2)			
9	P12V	10	P12V
11	P12V	12	P12V
13	P12V	14	P12V
15	P12V	16	P12V

## 3. 2x40 Pin Bridge Board Connector

The Compute Node provides four SATA/SAS ports (in SCU0) to backplane, together with front panel control signals and SMBus\*.

**Table 55. 2x40 Pin Connector Pin-out for Node Bridge Board**

Pin	Signal Description	Pin	Signal Description
1	5V_AUX	2	5V_AUX
3	SATA0_TXN	4	USB2_OC
5	SATA0_TXP	6	GND
7	GND	8	SATA0_RXN
9	NODE_Present_N (GND)	10	SATA0_RXP
11	ALL_NODE_OFF	12	GND
13	spare	14	USB2_P0P
15	GND	16	USB2_P0N
17	IPMB-Data	18	GND
19	IPMB-Clk	20	FP HDD_ACT_LED_N

Pin	Signal Description	Pin	Signal Description
21	GND	22	FP Activity LED_N
23	SMBUS_R1 DATA	24	FP Health LEDA_N
25	SMBUS_R1 CLK	26	FP Health LEDG_N
27	GND	28	FP PWR LED_N
29	SMBUS_R5 DATA	30	FP ID LED_N
31	SMBUS_R5 CLK	32	FP ID BTN_N
33	GND	34	FP RST BTN_N
35	SMBUS_R7 DATA	36	FP PWR BTN_N
37	SMBUS_R7 CLK	38	FP NMI BTN_N
39	GND	40	SPA_SOUT_N
41	PMBUS Alert_N	42	SPA_SIN_N
43	NODEx_ON_N	44	ID3
45	SGPIO DATA IN	46	ID2
47	SGPIO Data Out	48	ID1
49	SGPIO LD	50	ID0
51	SPKR	52	SGPIO CLK
53	GND	54	GND
55	SAS3_RX	56	SAS3_TX
57	SAS3_RX	58	SAS3_TX
59	GND	60	GND
61	SAS2_TX	62	SAS2_RX
63	SAS2_TX	64	SAS2_RX
65	GND	66	GND
67	SAS1_RX	68	SAS1_TX
69	SAS1_RX	70	SAS1_TX
71	GND	72	GND
73	SAS0_TX	74	SAS0_RX
75	SAS0_TX	76	SAS0_RX
77	GND	78	GND
79	3.3V	80	3.3V

#### 4. 20-Pin Front Panel Connector

The backplanes provide connectors for front panel control signals. Each connector integrates the control signals of two compute nodes.

**Table 56. Front Panel Connector Pin-out**

Pin	Signal Description
1	GND
2	FP1_PWR_BTN_N
3	FP1_RST_BTN_N
4	FP1_ID_BTN_N
5	P5VSB
6	FP1_PWR_LED_N
7	FP1_HEALTH_LEDG_N
8	FP1_HEALTH_LEDA_N

Pin	Signal Description
9	FP1_ACTIVITY_LED_N
10	FP1_ID_LED_N
11	GND
12	FP2_PWR_BTN_N
13	FP2_RST_BTN_N
14	FP2_ID_BTN_N
15	P3V3SB
16	FP2_PWR_LED_N
17	FP2_HEALTH_LEDG_N
18	FP2_HEALTH_LEDG_N
19	FP2_ACTIVITY_LED_N
20	FP2_ID_LED_N

## 5. 2x7 Pin Power Supply Control Signal Connector

The backplanes provide power supply control signals, together with PMBus\* functionality integrated.

**Table 57. Power Supply Control Connector Pin-out**

Pin	Signal Description	Pin	Signal Description
1	SMBUS_R7_DATA	2	A0
3	SMBUS_R7_CLK	4	PSON_N
5	PMBUS_ALERT_N	6	12V RS_RTN
7	PWROK	8	12V RS
9	Reserved	10	PDU1-12VSB
11	PDU1-12VSB	12	PDU2-12VSB
13	PDU2-12VSB	14	Reserved

## 7. Front Panel Control and Indicators

The Intel® Server System H2000JF family Front Control Panel is integrated with rack handles at the both sides of the chassis. Each control panel contains two sets of node control buttons and status LEDs. The control panel assembly is pre-assembled and fixed with the rack handles.

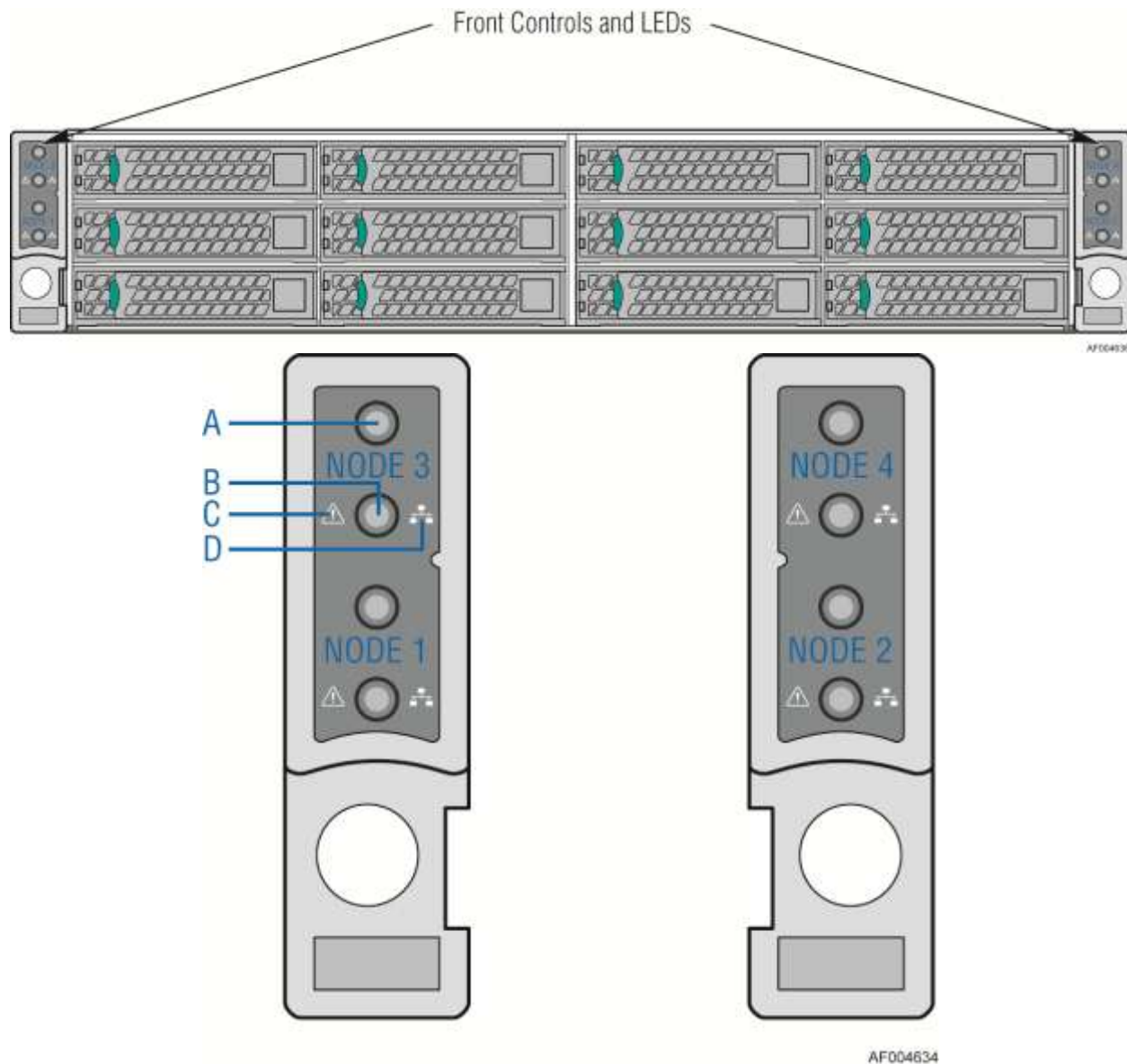

<b>A</b>	System Power Button with LED
<b>B</b>	System ID LED Button
<b>C</b>	System Status LED
<b>D</b>	Network Link/Activity LED

Figure 42. Front Control Panel

## 7.1 Control Panel Button

The following table lists the control panel features and functions. The control panel features a system power button.

**Table 58. Front Control Button Function**

Feature	Function
Power Button with Power LED	Toggles the system power on/off. This button also integrates the power LED.
System ID Button with ID LED	Toggles between ID LED on and off

## 7.2 Control Panel LED Indicators

The control panel houses independent two LEDs and two button integrated LEDs for each node, which are viewable to display the system's operating status. The following table identifies each LED and describes their functionality.

**Table 59. Front LED Indicator Functions**

LED Indicator	Color	Condition	Description
Power	Green	On	Power On / ACPI S0 state
	Green	Blink	Sleep / ACPI S1 state
	-	Off	Power Off / ACPI S5 state
LAN (i350 Dual NIC)	Green	On	LAN Link no Access
	Green	Blink	LAN Activity
	-	Off	No Link
System Status	Green	On	System Ready / No Alarm
	Green	Blink	System ready, but degraded: redundancy lost such as the power supply or fan failure; non-critical temp/voltage threshold; battery failure; or predictive power supply failure.
	Amber	On	Critical Alarm: Critical power modules failure, critical fans failure, voltage (power supply), critical temperature and voltage
	Amber	Blink	Non-Critical Alarm: Redundant fan failure, redundant power module failure, non-critical temperature and voltage
	-	Off	Power off: System unplugged Power on: System powered off and in standby, no prior degraded\non-critical\critical state

**Notes:**

1. Blink rate is ~1 Hz at 50% duty cycle.
2. It is also off when the system is powered off (S5) or in a sleep state (S1).
3. The power LED sleep indication is maintained on standby by the chipset. If the system is powered down without going through the BIOS, the LED state in effect at the time of power off is restored when the system is powered on until the BIOS clears it.
4. If the system is not powered down normally, it is possible the Power LED will blink at the same time the system status LED is off due to a failure or configuration change that prevents the BIOS from running.



## 7.2.1 Power/Sleep LED

**Table 60. Power LED Operation**

State	Power Mode	LED	Description
Power Off	Non-ACPI	Off	System power is off and the BIOS has not initialized the chipset.
Power On	Non-ACPI	Solid On	System power is on but the BIOS has not yet initialized the chipset.
S5	ACPI	Off	Mechanical is off and the operating system has not saved any context to the hard disk.
S1 Sleep	ACPI	Blink	DC power is still on. The operating system has saved context and gone into a level of low-power state.
S0	ACPI	Solid On	System and the operating system are up and running.

**Note:** Blink rate is ~ 1Hz at 50% duty cycle.

## 7.2.2 System Status LED

**Table 61. System Status LED Operation**

Color	State	Criticality	Description
Off	N/A	Not ready	Power off or BMC initialization completes if no degraded, non-critical, critical, or non-recoverable conditions exist after power cable plug-in.
Green/ Amber	Both Solid On	Not ready	Pre DC Power On – 15-20 second BMC Initialization when AC is applied to the server. The system will not POST until BMC initialization completes.
Green	Solid on	Ok	System ready.
Green	Blink	Degraded	<p>BIOS detected:</p> <ol style="list-style-type: none"> <li>Unable to use all of the installed memory (more than one DIMM installed).<sup>1</sup></li> <li>In a mirrored configuration, when memory mirroring takes place and system loses memory redundancy. This is not covered by (2).<sup>1</sup></li> <li>PCI Express* correctable link errors.</li> </ol> <p>Integrated BMC detected:</p> <ol style="list-style-type: none"> <li>One of redundant power supplies not present.</li> <li>CPU disabled – if there are two CPUs and one CPU is disabled.</li> <li>Fan alarm – Fan failure. Number of operational fans should be more than minimum number needed to cool the system.</li> <li>Non-critical threshold crossed – Temperature, voltage, power nozzle, power gauge, and PROCHOT2 (Therm Ctrl) sensors.</li> <li>Battery failure.</li> <li>Predictive failure when the system has redundant power supplies.</li> </ol>
Amber	Blink	Non-critical	<p>Non-fatal alarm – System is likely to fail.</p> <p>BIOS Detected:</p> <ol style="list-style-type: none"> <li>In non-mirroring mode, if the threshold of ten correctable errors is crossed within the window.<sup>1</sup></li> <li>PCI Express* uncorrectable link errors.</li> </ol> <p>Integrated BMC Detected:</p> <ol style="list-style-type: none"> <li>Critical threshold crossed – Voltage, temperature, power nozzle, power gauge, and PROCHOT (Therm Ctrl) sensors.</li> </ol>

Color	State	Criticality	Description
			2. VRD Hot asserted. 3. One of the redundant power supplies failed. 4. Minimum number of fans to cool the system are not present or have failed.
Amber	Solid on	Critical, non-recoverable	Fatal alarm – System has failed or shut down. BIOS Detected: <ol style="list-style-type: none"> <li>DIMM failure when there is one DIMM present and no good memory is present.<sup>1</sup></li> <li>Run-time memory uncorrectable error in non-redundant mode.<sup>1</sup></li> <li>CPU configuration error (for instance, processor stepping mismatch).</li> </ol> Integrated BMC Detected: <ol style="list-style-type: none"> <li>CPU CATERR signal asserted.</li> <li>CPU 1 is missing.</li> <li>CPU THERMTRIP.</li> <li>System cooling fan failure.</li> <li>No power good – Redundant power fault.               <ul style="list-style-type: none"> <li>Power Unit Redundancy sensor – Insufficient resources offset (indicates not enough power supplies are present).</li> </ul> </li> </ol>

**Notes:**

- The BIOS detects these conditions and sends a *Set Fault Indication* command to the Integrated BMC to provide the contribution to the system status LED.
- Blink rate is ~ 1Hz at 50% duty cycle.

### 7.2.3 System Status LED – BMC Initialization

When power is first applied to the system and 5V-STBY is present, the BMC controller on the server board requires 15-20 seconds to initialize. During this time, the system status LED will be solid on, both amber and green. After BMC initialization has completed, the status LED will stay green solid on. If power button is pressed before BMC initialization completes, the system will not boot to POST.

## 8. Configuration Jumpers

The following table provides a summary and description of configuration, test, and debug jumpers on the Intel® Server Board S2600JF, which is used in Intel® Server System H2000JF Family as Compute Node.

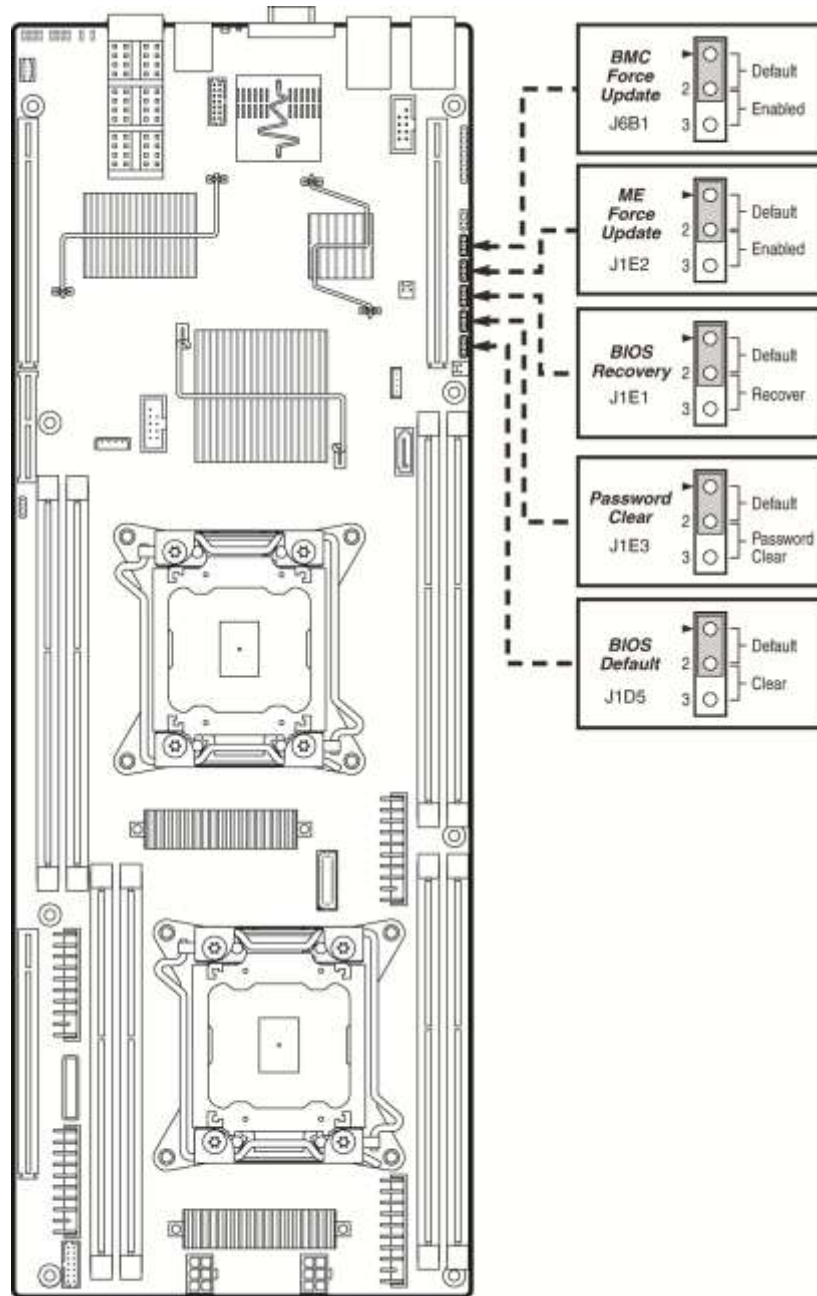

AF004227

Figure 43. Jumper Locations and Functions

**Table 62. Force Integrated BMC Update Jumper**

Jumper Name	Jumper Position	Mode of Operation	Note
J6B1: BMC Force Update jumper	1-2	Normal	Normal mode
	2-3	Update	BMC in force update mode
J1E2: ME Force Update	1-2	Normal	Normal mode
	2-3	Update	ME in force update mode
J1E3: Password Clear	1-2	Normal	Normal mode, password in protection
	2-3	Clear Password	BIOS password is cleared
J1E1: BIOS Recovery Mode	1-2	Normal	Normal mode
	2-3	Recovery	BIOS in recovery mode
J1D5: BIOS Default	1-2	Normal	Normal mode
	2-3	Clear BIOS Settings	BIOS settings are reset to factory default

## 8.1 Force Integrated BMC Update (J6B1)

When performing a standard BMC firmware update procedure, the update utility places the BMC into an update mode, allowing the firmware to load safely onto the flash device. In the unlikely event the BMC firmware update process fails due to the BMC not being in the proper update state, the server board provides a BMC Force Update jumper (J6B1) which will force the BMC into the proper update state. The following procedure should be followed in the event the standard BMC firmware update process fails.

**Table 63. Force Integrated BMC Update Jumper**

Jumper Position	Mode of Operation	Note
1-2	Normal	Normal Operation
2-3	Update	BMC in force update mode

Steps to perform the Force Integrated BMC Update:

1. Power down and remove the AC power cord.
2. Open the server chassis. See your server chassis documentation for instructions.
3. Move jumper from the default operating position (covering pins 1 and 2) to the enabled position (covering pins 2 and 3).
4. Close the server chassis.
5. Reconnect the AC cord and power up the server.
6. Perform the BMC firmware update procedure as documented in the ReleaseNote.TXT file included in the given BMC firmware update package. After successful completion of the firmware update process, the firmware update utility may generate an error stating the BMC is still in update mode.
7. Power down and remove the AC power cord.
8. Open the server chassis.
9. Move the jumper from the enabled position (covering pins 2 and 3) to the disabled position (covering pins 1 and 2).
10. Close the server chassis.
11. Reconnect the AC cord and power up the server.

---

**Note:** Normal BMC functionality is disabled with the Force BMC Update jumper set to the enabled position. You should never run the server with the BMC Force Update jumper set in this position. You should only use this jumper setting when the standard firmware update process fails. This jumper should remain in the default/disabled position when the server is running normally.

---

The server board has several 3-pin jumper blocks that can be used to configure, protect, or recover specific features of the server board.

## 8.2 Force ME Update (J1E2)

When this 3-pin jumper is set, it manually puts the ME firmware in update mode, which enables the user to update ME firmware code when necessary.

**Table 64. Force ME Update Jumper**

Jumper Position	Mode of Operation	Note
1-2	Normal	Normal operation
2-3	Update	ME in force update mode

---

**Note:** Normal ME functionality is disabled with the Force ME Update jumper set to the enabled position. You should never run the server with the ME Force Update jumper set in this position. You should only use this jumper setting when the standard firmware update process fails. This jumper should remain in the default/disabled position when the server is running normally.

---

Steps to perform the Force ME Update:

1. Power down and remove the AC power cord.
2. Open the server chassis. For instructions, see your server chassis documentation.
3. Move jumper from the default operating position (covering pins 1 and 2) to the enabled position (covering pins 2 and 3).
4. Close the server chassis.
5. Reconnect the AC cord and power up the server.
6. Perform the ME firmware update procedure as documented in the README.TXT file that is included in the given ME firmware update package (same package as BIOS).
7. Power down and remove the AC power cord.
8. Open the server chassis.
9. Move jumper from the enabled position (covering pins 2 and 3) to the disabled position (covering pins 1 and 2).
10. Close the server chassis.

## 8.3 Password Clear (J1E3)

This 3-pin jumper is used to clear the BIOS password.

**Table 65. BIOS Password Clear Jumper**

Jumper Position	Mode of Operation	Note
1-2	Normal	Normal mode. Password in protection
2-3	Clear Password	BIOS password is cleared

Steps to perform the password clear:

1. Power down server. Do not unplug the power cord.
2. Open the chassis. For instructions, refer to your server chassis documentation.
3. Move the jumper (J1F2) from the default operating position (covering pins 1 and 2) to the password clear position (covering pins 2 and 3).
4. Close the server chassis.
5. Power up the server, wait 10 seconds or until POST completes.
6. Power down the server.
7. Open the chassis and move the jumper back to default position (covering pins 1 and 2).
8. Close the server chassis.
9. Power up the server. The password is now cleared and you can reset it by going into the BIOS setup. The BIOS password is now cleared.

## 8.4 BIOS Recovery Mode (J1E1)

The Intel® Server Board S2600JF uses BIOS recovery to repair the system BIOS from flash corruption in the main BIOS and Boot Block. This 3-pin jumper is used to reload the BIOS when the image is suspected to be corrupted. For directions on how to recover the BIOS, refer to the specific *BIOS Release Notes*.

**Table 66. BIOS Recovery Mode Jumper**

Jumper Position	Mode of Operation	Note
1-2	Normal	Normal mode
2-3	Recovery	BIOS in recovery mode

You can accomplish a BIOS recovery from the SATA CD and USB Mass Storage device. Note that this platform does not support recovery from a USB floppy.

The recovery media must contain the following files under the root directory:

1. RML.ROM
2. UEFI iFlash32 11.0 Build 2 (including iFlash32.efi and ipmi.efi)
3. \*Rec.CAP
4. Startup.nsh (update accordingly to use proper \*Rec.CAP file)

The BIOS starts the recovery process by first loading and booting to the recovery image file (RML.ROM) on the root directory of the recovery media (USB disk). This process takes place

before any video or console is available. After the system boots to this recovery image file (FVMAIN.FV), it boots automatically into the EFI Shell to invoke the Startup.nsh script and start the flash update application (IFlash32.efi). IFlash32.efi requires the supporting BIOS Capsule image file (\*Rec.CAP).

After the update is complete, a message displays, stating the “BIOS has been updated successfully”. This indicates the recovery process is finished.

The user should then switch the recovery jumper back to normal operation and restart the system by performing a power cycle.

The following steps demonstrate this recovery process:

1. Power off the system.
2. Insert recovery media.
3. Switch the recovery jumper. Details regarding the jumper ID and location can be obtained from the Board EPS for that Platform.
4. Power on the system.
5. The BIOS POST screen appears displaying the progress, and the system automatically boots to the EFI SHELL.
6. The Startup.nsh file executes, and initiates the flash update (IFlash32.efi) with a new capsule file (\*Rec.CAP). The regular iFlash message displays at the end of the process—after the flash update succeeds.
7. Power off the system, and revert the recovery jumper position to "normal operation".
8. Power on the system.
9. Do NOT interrupt the BIOS POST during the first boot.

## 8.5 Reset BIOS Settings (J1D5)

This jumper is used to be the CMOS Clear jumper. The BIOS has moved CMOS data to the NVRAM region of the BIOS flash since the previous generation. The BIOS checks during boot to determine whether the data in the NVRAM must be set to default.

**Table 67. Reset BIOS Jumper**

Jumper Position	Mode of Operation	Note
1-2	Normal	These pins should have a jumper in place for normal system operation (Default).
2-3	Reset BIOS Configuration	If these pins 2-3 are connected with AC power plugged, the CMOS settings are cleared within five seconds. These pins should not be connected for normal operation.

Steps to reset the BIOS settings to default:

1. Power down server. Do not unplug the power cord.
2. Open the server chassis. For instructions, see your server chassis documentation.

3. Move jumper (J1D5) from the default operating position (covering pins 1 and 2) to the reset/clear position (covering pins 2 and 3).
4. Wait five seconds.
5. Remove AC power.
6. Move the jumper back to default position (covering pins 1 and 2).
7. Close the server chassis.
8. Power up the server.

The BIOS settings are now cleared and you can reset it by going into the BIOS setup.

---

**Note:** Removing AC Power before performing the BIOS settings Clear operation causes the system to automatically power up and immediately power down, after the procedure is followed and AC power is re-applied. If this happens, remove the AC power cord again, wait 30 seconds, and re-install the AC power cord. Power-up the system and proceed to the <F2> BIOS Setup Utility to reset the desired settings.

---



## 9. PCI Express\* Riser Card and Assembly

Each compute node in Intel® Server System H2000JF Family includes three PCI Express\* riser slots that accept dedicated PCI Express\* x16 Gen3 Risers to support low profile add-in card and Intel® IO module. Only Riser Slot 1 and Riser Slot 2 are available for risers. Riser Slot 3 is hidden by bridge board. The PCI Express\* slot on riser also accommodates PCI Express\* x8, x4, and x1 adapters.

### 9.1 PCI Express\* Riser for Slot 1

#### 9.1.1 Overview of PCI-Express\* Riser

Riser slot 1 on baseboard provides standard PCI Express\* x16 Gen3 signals, together with specific power pins to support high-power double width graphic add-in card.

**Note:** Riser Slot 1 on baseboard only supports Intel® 1U/2U Risers. It will cause damage to any PCI-E based add-in card, which is directly plugged into the Riser Slot 1 on baseboard.

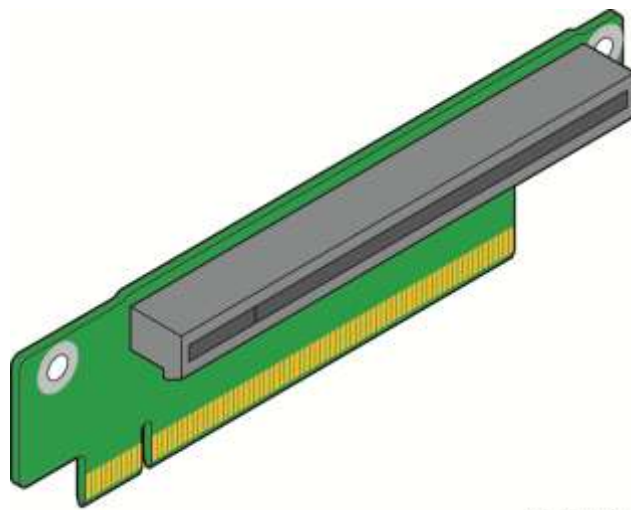

AF004224

Figure 44. PCI Express\* Riser for Riser Slot 1

#### 9.1.2 Pin-out Definition on Slot 1 Riser

The following table is a list of pin definition on Slot 1 Riser.

Table 68. Riser Card Edge Pin-out

Pin	Pin Name	Description	Pin	Pin Name	Description
B1	12V	20W 3.3V generated on riser	A1	12V	20W 3.3V generated on riser
B2	12V	66W for double width add-in card	A2	12V	66W for double width add-in card
B3	12V	66W for double width add-in card	A3	12V	66W for double width add-in card
B4	12V	66W for double width add-in card	A4	SMDATA	

Pin	Pin Name	Description	Pin	Pin Name	Description
B5	SMCLK		A5	3.3VAUX	For wake on LAN
B6	3.3VAUX	For wake on LAN	A6	GPU_NODE_ON	Turn on double width card power
B7	GND		A7	GPU_PWRGD	
B8	Tach9		A8	Tach11	
B9	Tach8		A9	Tach10	
B10	Tach7		A10	Tach6	
B11	Spare		A11	Spare	
KEY					
B12	Spare		A12	PWM2	Double width card fan speed control
B13	Spare		A13	GND	
B14	GND		A14	PERST#	
B15	SMBUS_R4 CLK		A15	WAKE#	
B16	SMBUS_R4 DAT		A16	GND	
B17	GND		A17	REFCLK+	Clock pair 1
B18	PETxP0	Tx Lane 0+	A18	REFCLK-	Clock pair 1
B19	PETxN0	Tx Lane 0-	A19	GND	
B20	GND		A20	PERxP0	Rx Lane 0+
B21	GND		A21	PERxN0	Rx Lane 0-
B22	PETxP1	Tx Lane 1+	A22	GND	
B23	PETxN1	Tx Lane 1-	A23	GND	
B24	GND		A24	PERxP1	Rx Lane 1+
B25	GND		A25	PERxN1	Rx Lane 1-
B26	PETxP2	Tx Lane 2+	A26	GND	
B27	PETxN2	Tx Lane 2-	A27	GND	
B28	GND		A28	PERxP2	Rx Lane 2+
B29	GND		A29	PERxN2	Rx Lane 2-
B30	PETxP3	Tx Lane 3+	A30	GND	
B31	PETxN3	Tx Lane 3-	A31	GND	
B32	GND		A32	PERxP3	Rx Lane 3+
B33	GND		A33	PERxN3	Rx Lane 3-
B34	PETxP4	Tx Lane 4+	A34	GND	
B35	PETxN4	Tx Lane 4-	A35	GND	
B36	GND		A36	PERxP4	Rx Lane 4+
B37	GND		A37	PERxN4	Rx Lane 4-
B38	PETxP5	Tx Lane 5+	A38	GND	
B39	PETxN5	Tx Lane 5-	A39	GND	
B40	GND		A40	PERxP5	Rx Lane 5+
B41	GND		A41	PERxN5	Rx Lane 5-
B42	PETxP6	Tx Lane 6+	A42	GND	

Pin	Pin Name	Description	Pin	Pin Name	Description
B43	PETxN6	Tx Lane 6-	A43	GND	
B44	GND		A44	PERxP6	Rx Lane 6+
B45	GND		A45	PERxN6	Rx Lane 6-
B46	PETxP7	Tx Lane 7+	A46	GND	
B47	PETxN7	Tx Lane 7-	A47	GND	
B48	GND		A48	PERxP7	Rx Lane 7+
B49	GND		A49	PERxN7	Rx Lane 7-
B50	PETxP8	Tx Lane 8+	A50	GND	
B51	PETxN8	Tx Lane 8-	A51	GND	
B52	GND		A52	PERxP8	Rx Lane 8+
B53	GND		A53	PERxN8	Rx Lane 8-
B54	PETxP9	Tx Lane 9+	A54	GND	
B55	PETxN9	Tx Lane 9-	A55	GND	
B56	GND		A56	PERxP9	Rx Lane 9+
B57	GND		A57	PERxN9	Rx Lane 9-
B58	PETxP10	Tx Lane 10+	A58	GND	
B59	PETxN10	Tx Lane 10-	A59	GND	
B60	GND		A60	PERxP10	Rx Lane 10+
B61	GND		A61	PERxN10	Rx Lane 10-
B62	PETxP11	Tx Lane 11+	A62	GND	
B63	PETxN11	Tx Lane 11-	A63	GND	
B64	GND		A64	PERxP11	Rx Lane 11+
B65	GND		A65	PERxN11	Rx Lane 11-
B66	PETxP12	Tx Lane 12+	A66	GND	
B67	PETxN12	Tx Lane 12-	A67	GND	
B68	GND		A68	PERxP12	Rx Lane 12+
B69	GND		A69	PERxN12	Rx Lane 12-
B70	PETxP13	Tx Lane 13+	A70	GND	
B71	PETxN13	Tx Lane 13-	A71	GND	
B72	GND		A72	PERxP13	Rx Lane 13+
B73	GND		A73	PERxN13	Rx Lane 13-
B74	PETxP14	Tx Lane 14+	A74	GND	
B75	PETxN14	Tx Lane 14-	A75	GND	
B76	GND		A76	PERxP14	Rx Lane 14+
B77	REFCLK+	Clock pair 2	A77	PERxN14	Rx Lane 14-
B78	REFCLK-	Clock pair 2	A78	GND	
B79	GND		A79	PERxP15	Rx Lane 15+
B80	PETxP15	Tx Lane 15+	A80	PERxN15	Rx Lane 15-
B81	PETxN15	Tx Lane 15-	A81	GND	
B82	GND		A82	Riser ID	Fix to High: PCIe x16

There is a standard PCI Express\* Gen3 x16 slot on riser card for PCI-E\* based add-in card. The pin definition for the slot is as below.

**Table 69. PCI Express\* Slot Pin-out on Riser Card**

Pin-Side B	PCI Spec Signal	Pin-Side A	PCI Spec Signal
82	RSVD	82	GND
81	PRSNT2#	81	HSIN15
80	GND	80	HSIP15
79	HSO15	79	GND
78	HSOP15	78	GND
77	GND	77	HSIN14
76	GND	76	HSIP14
75	HSO14	75	GND
74	HSOP14	74	GND
73	GND	73	HSIN13
72	GND	72	HSIP13
71	HSO13	71	GND
70	HSOP13	70	GND
69	GND	69	HSIN12
68	GND	68	HSIP12
67	HSO12	67	GND
66	HSOP12	66	GND
65	GND	65	HSIN11
64	GND	64	HSIP11
63	HSO11	63	GND
62	HSOP11	62	GND
61	GND	61	HSIN10
60	GND	60	HSIP10
59	HSO10	59	GND
58	HSOP10	58	GND
57	GND	57	HSIN9
56	GND	56	HSIP9
55	HSO9	55	GND
54	HSOP9	54	GND
53	GND	53	HSIN8
52	GND	52	HSIP8
51	HSO8	51	GND
50	HSOP8	50	RSVD
49	GND	49	GND
48	PRSNT2#	48	HSIN7
47	GND	47	HSIP7
46	HSO7	46	GND
45	HSOP7	45	GND
44	GND	44	HSIN6
43	GND	43	HSIP6
42	HSO6	42	GND

Pin-Side B	PCI Spec Signal	Pin-Side A	PCI Spec Signal
41	HSOP6	41	GND
40	GND	40	HSIN5
39	GND	39	HSIP5
38	HSOP5	38	GND
37	GND	37	GND
36	GND	36	HSIN4
35	GND	35	HSIP4
34	HSOP4	34	GND
33	GND	33	RSVD
32	PRSENT2#	32	RSVD
31	RSVD	31	GND
30	GND	30	HSIN3
29	HSOP3	29	HSIP3
28	GND	28	GND
27	HSOP3	27	GND
26	GND	26	HSIN2
25	GND	25	HSIP2
24	HSOP2	24	GND
23	GND	23	GND
22	HSOP2	22	HSIN1
21	GND	21	HSIP1
20	HSOP1	20	GND
19	GND	19	RSVD
18	PRSENT2#	18	GND
17	GND	17	HSIN0
16	HSOP0	16	HSIP0
15	GND	15	GND
14	HSOP0	14	REFCLK-
13	GND	13	REFCLK+
12	RSVD	12	GND
KEY		KEY	
KEY		KEY	
11	WAKE#	11	PWRGD
10	3.3V AUX	10	3.3V
9	JTAG1	9	3.3V
8	3.3V	8	JTAG5
7	GND	7	JTAG4
6	SMDAT	6	JTAG3
5	SMCLK	5	JTAG2
4	GND	4	GND
3	RSVD	3	12V
2	12V	2	12V
1	12V	1	PRSENT1#

## 9.2 PCI Express\* Riser with IOM Carrier for Slot 2 (Optional)

### 9.2.1 Overview of PCI-E\* Riser with IOM Carrier

The Riser with IOM carrier is provided as accessory to the server system. It is combined with below functions:

- Provide PCI Express\* x8 Gen 3 signals from riser
- Integrated 1GbE management port for Intel® Remote Management Module 4
- Support PCI-E\* x4 based Intel® IO Module

Riser slot 2 on baseboard provides standard PCI Express\* x16 Gen3 signals, together with specific power pins to support high-power double width Graphic add-in card.

---

**Note:** Riser Slot 2 on baseboard only supports Intel® 1U/2U Risers. It will cause damage to any PCI-E\* based add-in card, which is directly plugged into the Riser Slot 1.

---

The PCI-E\* slot on Riser is x16 mechanically with x8 electrically. The IOM carrier is using PCI-E\* x8 card edge with PCI-E\* x4 IO module slot.

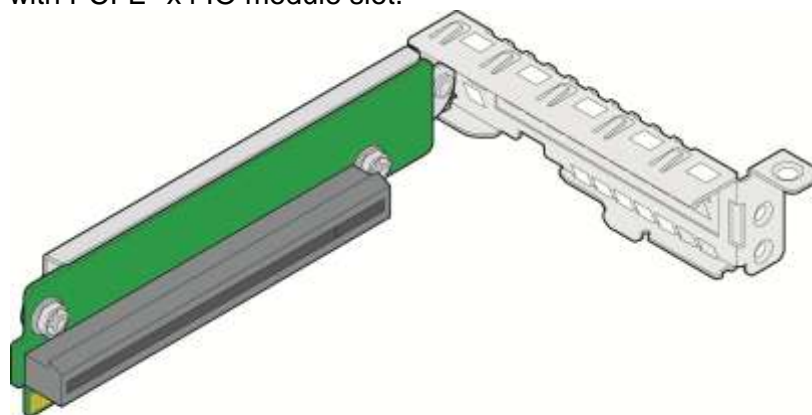

AF004225

Figure 45. PCI Express\* Riser with Bracket for Riser Slot 2

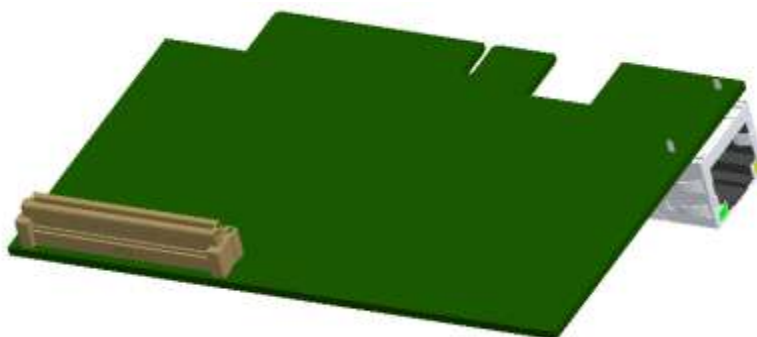

Figure 46. IOM Carrier

The 1GbE port is dedicated NIC port for RMM4 Lite module. It only works after the RMM4 Lite module is installed in the system. The LED of dedicated NIC port is following the definition below.

**Table 70. Dedicated NIC Port LED Functionality**

LED	Color	Condition	Functionality
Dedicated NIC Speed	Green	On	1Gbps mode
	Amber	On	100Mbps mode
		Off	10Mbps mode
Dedicated NIC Activity	Green	On	LAN link and no access
	Green	Blink	LAN access
		Off	Idle

## 9.2.2 Pin-out Definition on Slot 2 Riser and IOM Carrier

Following is a list of pin definition for Slot 2 Riser and IOM Carrier.

**Table 71. Riser Card Edge Pin-out**

Pin	Pin Name	Description	Pin	Pin Name	Description
B1	12V	20W 3.3V generated on riser	A1	12V	20W 3.3V generated on riser
B2	12V	66W for double width add-in card	A2	12V	66W for double width add-in card
B3	12V	66W for double width add-in card	A3	12V	66W for double width add-in card
B4	12V	66W for double width add-in card	A4	SMDATA	For rIOM temp sensor
B5	SMCLK	for rIOM temp sensor	A5	5VAUX	For DNM and IOM wake on LAN
B6	3.3V Aux	For DNM and IOM wake on LAN	A6	PRESENT#	DNM function present
B7	GND		A7	RIOM_ACT#	
B8	TXD_0	RGMIl txmit data	A8	RXD_3	RGMIl receive data
B9	TXD_1	RGMIl txmit data	A9	RXD_2	RGMIl receive data
B10	TXD_2	RGMIl txmit data	A10	RXD_1	RGMIl receive data
B11	TXD_3	RGMIl txmit data	A11	RXD_0	RGMIl receive data
KEY					
B12	GND		A12	RX_CTL	RGMIl receive Cntrl
B13	TX_CLK	RGMIl txmit Clock	A13	GND	
B14	TX_CTL	RGMIl txmit Cntrl	A14	RX_CLK	RGMIl receive Clock
B15	MDIO		A15	MDC	
B16	PERST#		A16	GND	
B17	WAKE#		A17	REFCLK+	Clock pair 1
B18	PETxP0	Tx Lane 0+	A18	REFCLK-	Clock pair 1
B19	PETxN0	Tx Lane 0-	A19	GND	

Pin	Pin Name	Description	Pin	Pin Name	Description
B20	GND		A20	PERxP0	Rx Lane 0+
B21	GND		A21	PERxN0	Rx Lane 0-
B22	PETxP1	Tx Lane 1+	A22	GND	
B23	PETxN1	Tx Lane 1-	A23	GND	
B24	GND		A24	PERxP1	Rx Lane 1+
B25	GND		A25	PERxN1	Rx Lane 1-
B26	PETxP2	Tx Lane 2+	A26	GND	
B27	PETxN2	Tx Lane 2-	A27	GND	
B28	GND		A28	PERxP2	Rx Lane 2+
B29	GND		A29	PERxN2	Rx Lane 2-
B30	PETxP3	Tx Lane 3+	A30	GND	
B31	PETxN3	Tx Lane 3-	A31	GND	
B32	GND		A32	PERxP3	Rx Lane 3+
B33	GND		A33	PERxN3	Rx Lane 3-
B34	PETxP4	Tx Lane 4+	A34	GND	
B35	PETxN4	Tx Lane 4-	A35	GND	
B36	GND		A36	PERxP4	Rx Lane 4+
B37	GND		A37	PERxN4	Rx Lane 4-
B38	PETxP5	Tx Lane 5+	A38	GND	
B39	PETxN5	Tx Lane 5-	A39	GND	
B40	GND		A40	PERxP5	Rx Lane 5+
B41	GND		A41	PERxN5	Rx Lane 5-
B42	PETxP6	Tx Lane 6+	A42	GND	
B43	PETxN6	Tx Lane 6-	A43	GND	
B44	GND		A44	PERxP6	Rx Lane 6+
B45	GND		A45	PERxN6	Rx Lane 6-
B46	PETxP7	Tx Lane 7+	A46	GND	
B47	PETxN7	Tx Lane 7-	A47	GND	
B48	GND		A48	PERxP7	Rx Lane 7+
B49	GND		A49	PERxN7	Rx Lane 7-
B50	PETxP8	Tx Lane 8+	A50	GND	
B51	PETxN8	Tx Lane 8-	A51	GND	
B52	GND		A52	PERxP8	Rx Lane 8+
B53	GND		A53	PERxN8	Rx Lane 8-
B54	PETxP9	Tx Lane 9+	A54	GND	
B55	PETxN9	Tx Lane 9-	A55	GND	
B56	GND		A56	PERxP9	Rx Lane 9+
B57	GND		A57	PERxN9	Rx Lane 9-
B58	PETxP10	Tx Lane 10+	A58	GND	
B59	PETxN10	Tx Lane 10-	A59	GND	
B60	GND		A60	PERxP10	Rx Lane 10+
B61	GND		A61	PERxN10	Rx Lane 10-



Pin	Pin Name	Description	Pin	Pin Name	Description
B62	PETxP11	Tx Lane 11+	A62	GND	
B63	PETxN11	Tx Lane 11-	A63	GND	
B64	GND		A64	PERxP11	Rx Lane 11+
B65	GND		A65	PERxN11	Rx Lane 11-
B66	PETxP12	Tx Lane 12+	A66	GND	
B67	PETxN12	Tx Lane 12-	A67	GND	
B68	GND		A68	PERxP12	Rx Lane 12+
B69	GND		A69	PERxN12	Rx Lane 12-
B70	PETxP13	Tx Lane 13+	A70	GND	
B71	PETxN13	Tx Lane 13-	A71	GND	
B72	GND		A72	PERxP13	Rx Lane 13+
B73	GND		A73	PERxN13	Rx Lane 13-
B74	PETxP14	Tx Lane 14+	A74	GND	
B75	PETxN14	Tx Lane 14-	A75	GND	
B76	GND		A76	PERxP14	Rx Lane 14+
B77	REFCLK+	Clock pair 2	A77	PERxN14	Rx Lane 14-
B78	REFCLK-	Clock pair 2	A78	GND	
B79	GND		A79	PERxP15	Rx Lane 15+
B80	PETxP15	Tx Lane 15+	A80	PERxN15	Rx Lane 15-
B81	PETxN15	Tx Lane 15-	A81	GND	
B82	GND		A82	Riser ID	Fix to Low: PCIe 2x8

Table 72 PCI Express\* Slot Pin-out on Riser Card

Pin-Side B	PCI Spec Signal	Pin-Side A	PCI Spec Signal
82	RSVD	82	GND
81	PRSNT2#	81	HSIN15
80	GND	80	HSIP15
79	HSO15	79	GND
78	HSOP15	78	GND
77	GND	77	HSIN14
76	GND	76	HSIP14
75	HSO14	75	GND
74	HSOP14	74	GND
73	GND	73	HSIN13
72	GND	72	HSIP13
71	HSO13	71	GND
70	HSOP13	70	GND
69	GND	69	HSIN12
68	GND	68	HSIP12
67	HSO12	67	GND
66	HSOP12	66	GND
65	GND	65	HSIN11
64	GND	64	HSIP11

Pin-Side B	PCI Spec Signal	Pin-Side A	PCI Spec Signal
63	HSO11	63	GND
62	HSOP11	62	GND
61	GND	61	HSIN10
60	GND	60	HSIP10
59	HSO10	59	GND
58	HSOP10	58	GND
57	GND	57	HSIN9
56	GND	56	HSIP9
55	HSO9	55	GND
54	HSOP9	54	GND
53	GND	53	HSIN8
52	GND	52	HSIP8
51	HSO8	51	GND
50	HSOP8	50	RSVD
49	GND	49	GND
48	PRSNT2#	48	HSIN7
47	GND	47	HSIP7
46	HSO7	46	GND
45	HSOP7	45	GND
44	GND	44	HSIN6
43	GND	43	HSIP6
42	HSO6	42	GND
41	HSOP6	41	GND
40	GND	40	HSIN5
39	GND	39	HSIP5
38	HSO5	38	GND
37	HSOP5	37	GND
36	GND	36	HSIN4
35	GND	35	HSIP4
34	HSO4	34	GND
33	HSOP4	33	RSVD
32	GND	32	RSVD
31	PRSNT2#	31	GND
30	RSVD	30	HSIN3
29	GND	29	HSIP3
28	HSO3	28	GND
27	HSOP3	27	GND
26	GND	26	HSIN2
25	GND	25	HSIP2
24	HSO2	24	GND
23	HSOP2	23	GND
22	GND	22	HSIN1
21	GND	21	HSIP1
20	HSO1	20	GND
19	HSOP1	19	RSVD

Pin-Side B	PCI Spec Signal	Pin-Side A	PCI Spec Signal
18	GND	18	GND
17	PRSNT2#	17	HSIN0
16	GND	16	HSIP0
15	HSON0	15	GND
14	HSOP0	14	REFCLK-
13	GND	13	REFCLK+
12	RSVD	12	GND
KEY		KEY	
KEY		KEY	
11	WAKE#	11	PWRGD
10	3.3V AUX	10	3.3V
9	JTAG1	9	3.3V
8	3.3V	8	JTAG5
7	GND	7	JTAG4
6	SMDAT	6	JTAG3
5	SMCLK	5	JTAG2
4	GND	4	GND
3	RSVD	3	12V
2	12V	2	12V
1	12V	1	PRSNT1#

Table 73. IO Module Slot on Carrier

Pin	Signal	Signal	Pin
1	3.3V	12V	2
3	3.3V	12V	4
5	3.3V	12V	6
7	3.3V	12V	8
9	RSVD	FRU/TEMP ADDR [I]	10
11	GND	5VSB	12
13	RSVD+	FM_IO_MODULE_EN	14
15	RSVD-	3.3VSTBY	16
17	GND	LED_GLOBAL ACT#	18
19	RSVD	FM_IOM_PRESENT_N	20
21	RSVD	WAKE#	22
23	GND	PERST#	24
25	SMB CLK	GND	26
27	SMB DAT	rIOM REFCLK+ [0]	28
29	GND	rIOM REFCLK- [0]	30
31	PCIe Gen3 Tn [7]	GND	32
33	PCIe Gen3 Tp [7]	PCIe Gen3 Rn [7]	34

Pin	Signal	Signal	Pin
35	GND	PCIe Gen3 Rp [7]	36
37	PCIe Gen3 Tn [6]	GND	38
39	PCIe Gen3 Tp [6]	PCIe Gen3 Rn [6]	40
41	GND	PCIe Gen3 Rp [6]	42
43	PCIe Gen3 Tn [5]	GND	44
45	PCIe Gen3 Tp [5]	PCIe Gen3 Rn [5]	46
47	GND	PCIe Gen3 Rp [5]	48
49	PCIe Gen3 Tn [4]	GND	50
51	PCIe Gen3 Tp [4]	PCIe Gen3 Rn [4]	52
53	GND	PCIe Gen3 Rp [4]	54
55	PCIe Gen3 Tn [3]	GND	56
57	PCIe Gen3 Tp [3]	PCIe Gen3 Rn [3]	58
59	GND	PCIe Gen3 Rp [3]	60
61	PCIe Gen3 Tn [2]	GND	62
63	PCIe Gen3 Tp [2]	PCIe Gen3 Rn [2]	64
65	GND	PCIe Gen3 Rp [2]	66
67	PCIe Gen3 Tn [1]	GND	68
69	PCIe Gen3 Tp [1]	PCIe Gen3 Rn [1]	70
71	GND	PCIe Gen3 Rp [1]	72
73	PCIe Gen3 Tn [0]	GND	74
75	PCIe Gen3 Tp [0]	PCIe Gen3 Rn [0]	76
77	GND	PCIe Gen3 Rp [0]	78
79	RSVD	GND	80

## Appendix A: Integration and Usage Tips

Before attempting to integrate and configure your system, you should reference this section, which provides a list of useful information.

- After the system is integrated with processors, memory, and peripheral devices, the FRUSDR utility **must** be run to load the proper Sensor Data Record data to the integrated Server Management subsystem. Failure to run this utility may prevent Server Management from accurately monitoring system health and may affect system performance. The FRUSDR utility for this server system can either be run from the Intel® Deployment CDROM that came with your system, or can be downloaded from the Intel website referenced at the bottom of this page.
- To ensure the highest system reliability, make sure the latest system software is loaded on the server before deploying the system onto a live networking environment. This includes system BIOS, FRUSDR, BMC firmware, and hot-swap controller firmware. The system software can be updated using the Intel® Deployment CDROM that came with your system or can be downloaded from the Intel website referenced at the bottom of this page.
- System fans are not hot-swappable.
- Only supported memory validated by Intel should be used in this server system. A list of supported memory can be found in the *Intel® Server Board S2600JF Tested Memory List* which can be downloaded from the Intel website referenced at the bottom of this page.
- This system supports the Intel® Xeon® processor E5-2600 and E5-2600V2 sequence. You cannot use Intel® Xeon® processors not referenced on the supported processor list in this server system.
- You must use the CPU/memory air duct to maintain system thermals.
- To maintain system thermals, you must populate all hard drive bays with either a hard drive or drive blank.
- You must remove AC power from the system prior to opening the chassis for service

You can download the latest system documentation, drivers, and system software from the Intel® Support website at [http://www.intel.com/p/en\\_US/support/highlights/server/ss-h2000jf](http://www.intel.com/p/en_US/support/highlights/server/ss-h2000jf).

## Appendix B: POST Code LED Decoder

During the system boot process, the BIOS executes a number of platform configuration processes, each of which is assigned a specific hex POST code number. As each configuration routine is started, the BIOS displays the POST code to the POST Code Diagnostic LEDs on the back edge of the server board. To assist in troubleshooting a system hang during the POST process, you can use the diagnostic LEDs to identify the last POST process executed.

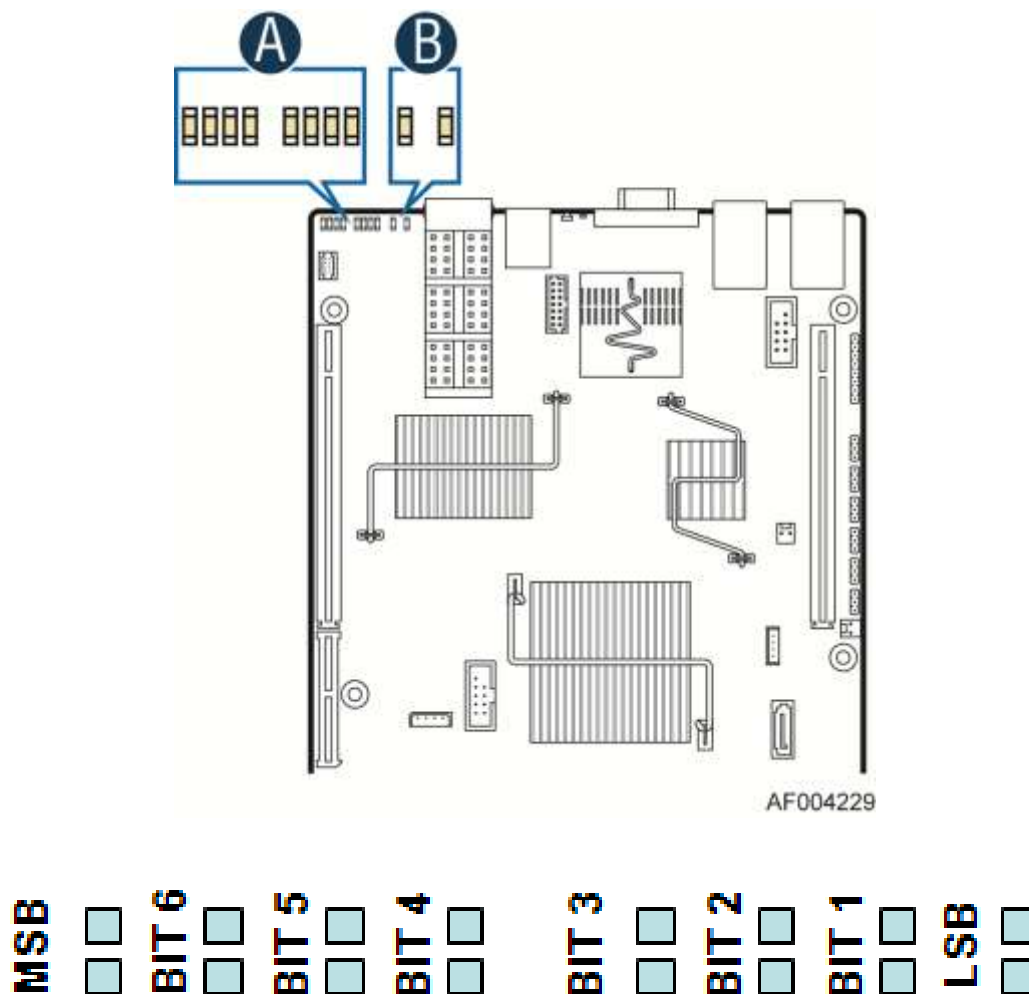

Figure 47. Diagnostic LED Location

Table 74. POST Code Diagnostic LED Location

A	ID LED	B	Status LED
C	Diagnostic LED #7 MSB	G	Diagnostic LED #3
D	Diagnostic LED #6	H	Diagnostic LED #2
E	Diagnostic LED #5	I	Diagnostic LED #1
F	Diagnostic LED #4	J	Diagnostic LED #0 LSB

Each POST code is represented by the eight amber diagnostic LEDs. The POST codes are divided into two nibbles, an upper nibble and a lower nibble. The upper nibble bits are represented by diagnostic LEDs #4, #5, #6, and #7. The lower nibble bits are represented by diagnostics LEDs #0, #1, #2, and #3. If the bit is set in the upper and lower nibbles, the corresponding LED is lit. If the bit is clear, the corresponding LED is off.

The diagnostic LED #7 is labeled as “MSB” (Most Significant Bit), and the diagnostic LED #0 is labeled as “LSB” (Least Significant Bit).

In the following example, the BIOS sends a value of ACh to the diagnostic LED decoder. The LEDs are decoded as follows.

**Table 75. POST Progress Code LED Example**

LEDs	Upper Nibble LEDs				Lower Nibble LEDs			
	MSB							LSB
	LED #7	LED #6	LED #5	LED #4	LED #3	LED #2	LED #1	LED #0
	8h	4h	2h	1h	8h	4h	2h	1h
Status	ON	OFF	ON	OFF	ON	ON	OFF	OFF
Results	1	0	1	0	1	1	0	0
	Ah				Ch			

Upper nibble bits = 1010b = Ah; Lower nibble bits = 1100b = Ch; the two are concatenated as ACh.

**Table 76. Diagnostic LED POST Code Decoder**

Progress Code	Description
<b>SEC Phase</b>	
0x01	First POST code after CPU reset
0x02	Microcode load begin
0x03	CRAM initialization begin
0x04	Pei Cache When Disabled
0x05	SEC Core At Power On Begin
0x06	Early CPU initialization during Sec Phase
0x07	Early SB initialization during Sec Phase
0x08	Early NB initialization during Sec Phase
0x09	End Of Sec Phase
0x0E	Microcode Not Found
0x0F	Microcode Not Loaded
<b>PEI Phase</b>	
0x10	PEI Core
0x11	CPU PEIM

Progress Code	Description
0x15	NB PEIM
0x19	SB PEIM
<b>MRC Progress Codes</b>	
<i>At this point the MRC Progress Code sequence is executed</i>	
0x31	Memory Installed
0x32	CPU PEIM (CPU Init)
0x33	CPU PEIM (Cache Init)
0x34	CPU PEIM (BSP Select)
0x35	CPU PEIM (AP Init)
0x36	CPU PEIM (CPU SMM Init)
0x4F	Dxe IPL started
<b>DXE Phase</b>	
0x60	DXE Core started
0x61	DXE NVRAM Init
0x62	SB RUN Init
0x63	DXE CPU Init
0x68	DXE PCI Host Bridge Init
0x69	DXE NB Init
0x6A	DXE NB SMM Init
0x70	DXE SB Init
0x71	DXE SB SMM Init
0x72	DXE SB devices Init
0x78	DXE ACPI Init
0x79	DXE CSM Init
0x90	DXE BDS Started
0x91	DXE BDS connect drivers
0x92	DXE PCI Bus begin
0x93	DXE PCI Bus HPC Init
0x94	DXE PCI Bus enumeration
0x95	DXE PCI Bus resource requested
0x96	DXE PCI Bus assign resource



Progress Code	Description
0x97	DXE CON_OUT connect
0x98	DXE CON_IN connect
0x99	DXE SIO Init
0x9A	DXE USB start
0x9B	DXE USB reset
0x9C	DXE USB detect
0x9D	DXE USB enable
0xA1	DXE IDE begin
0xA2	DXE IDE reset
0xA3	DXE IDE detect
0xA4	DXE IDE enable
0xA5	DXE SCSI begin
0xA6	DXE SCSI reset
0xA7	DXE SCSI detect
0xA8	DXE SCSI enable
0xA9	DXE verifying SETUP password
0xAB	DXE SETUP start
0xAC	DXE SETUP input wait
0xAD	DXE Ready to Boot
0xAE	DXE Legacy Boot
0xAF	DXE Exit Boot Services
0xB0	RT Set Virtual Address Map Begin
0xB1	RT Set Virtual Address Map End
0xB2	DXE Legacy Option ROM init
0xB3	DXE Reset system
0xB4	DXE USB Hot plug
0xB5	DXE PCI BUS Hot plug
0xB6	DXE NVRAM cleanup
0xB7	DXE Configuration Reset
0x00	INT19

Progress Code	Description
<b>S3 Resume</b>	
0xE0	S3 Resume PEIM (S3 started)
0xE1	S3 Resume PEIM (S3 boot script)
0xE2	S3 Resume PEIM (S3 Video Repost)
0xE3	S3 Resume PEIM (S3 OS wake)
<b>BIOS Recovery</b>	
0xF0	PEIM which detected forced Recovery condition
0xF1	PEIM which detected User Recovery condition
0xF2	Recovery PEIM (Recovery started)
0xF3	Recovery PEIM (Capsule found)
0xF4	Recovery PEIM (Capsule loaded)

## Appendix C: Video POST Code Errors

Whenever possible, the BIOS outputs the current boot progress codes on the video screen. Progress codes are 32-bit quantities plus optional data. The 32-bit numbers include class, subclass, and operation information. The class and subclass fields point to the type of hardware being initialized. The operation field represents the specific initialization activity. Based on the data bit availability to display progress codes, a progress code can be customized to fit the data width. The higher the data bit, the higher the granularity of information that can be sent on the progress port. The progress codes may be reported by the system BIOS or option ROMs.

The Response section in the following table indicates one of these actions:

**Minor:** The message is displayed on the screen or on the Error Manager screen, and an error is logged to the SEL. The system continues booting in a degraded state. The user may want to replace the erroneous unit. The POST Error Pause option setting in the BIOS setup does not have any effect on this error.

**Major:** The message is displayed on the Error Manager screen, and an error is logged to the SEL. The POST Error Pause option setting in the BIOS setup determines whether the system pauses to the Error Manager for this type of error so the user can take immediate corrective action or the system continues booting.

Note that for 0048 “Password check failed”, the system halts, and then after the next reset/reboot will displays the error code on the Error Manager screen.

**Fatal:** The system halts during post at a blank screen with the text “**Unrecoverable fatal error found. System will not boot until the error is resolved**” and “**Press <F2> to enter setup**” The POST Error Pause option setting in the BIOS setup does not have any effect with this class of error.

When the operator presses the **F2** key on the keyboard, the error message is displayed on the Error Manager screen, and an error is logged to the SEL with the error code. The system cannot boot unless the error is resolved. The user needs to replace the faulty part and restart the system.

Again, note that these Error Codes and the messages that go with them must be coordinated with the master list maintained by the Server Management Utilities team.

Be aware that the POST Error Code list shown in this table may contain error codes which do not necessarily apply uniformly to every platform. Only a subset of these error codes will be applicable to any given server board.

**Table 77. POST Error Message and Message**

Error Code	Error Message	Response
0012	System RTC date/time not set	Major
0048	Password check failed	Major
113	Fixed media not detected	Major
0140	PCI component encountered a PERR error	Major
0141	PCI resource conflict	Major
0146	PCI out of resources error	Major

Error Code	Error Message	Response
0191	Processor core/thread count mismatch detected	Fatal
0192	Processor cache size mismatch detected	Fatal
0194	Processor family mismatch detected	Fatal
0195	Processor Intel(R) QPI link frequencies unable to synchronize	Fatal
0196	Processor model mismatch detected	Fatal
0197	Processor frequencies unable to synchronize	Fatal
5220	BIOS Settings reset to default settings	Major
5221	Passwords cleared by jumper	Major
5224	Password clear jumper is Set	Major
8130	Processor 01 disabled	Major
8131	Processor 02 disabled	Major
8132	Processor 03 disabled	Major
8133	Processor 04 disabled	Major
8160	Processor 01 unable to apply microcode update	Major
8161	Processor 02 unable to apply microcode update	Major
8162	Processor 03 unable to apply microcode update	Major
8163	Processor 04 unable to apply microcode update	Major
8170	Processor 01 failed Self Test (BIST)	Major
8171	Processor 02 failed Self Test (BIST)	Major
8172	Processor 03 failed Self Test (BIST)	Major
8173	Processor 04 failed Self Test (BIST)	Major
8180	Processor 01 microcode update not found	Minor
8181	Processor 02 microcode update not found	Minor
8182	Processor 03 microcode update not found	Minor
8183	Processor 04 microcode update not found	Minor
8190	Watchdog timer failed on last boot	Major
8198	OS boot watchdog timer failure	Major
8300	Baseboard management controller failed self test	Major
8305	Hot Swap Controller failure	Major
83A0	Management Engine (ME) failed self test	Major
83A1	Management Engine (ME) Failed to respond.	Major
84F2	Baseboard management controller failed to respond	Major
84F3	Baseboard management controller in update mode	Major
84F4	Sensor data record empty	Major
84FF	System event log full	Minor
8500	Memory component could not be configured in the selected RAS mode	Major
8501	DIMM Population Error	Major
8520	DIMM_A1 failed test/initialization	Major
8521	DIMM_A2 failed test/initialization	Major
8522	DIMM_A3 failed test/initialization	Major
8523	DIMM_B1 failed test/initialization	Major
8524	DIMM_B2 failed test/initialization	Major
8525	DIMM_B3 failed test/initialization	Major
8526	DIMM_C1 failed test/initialization	Major
8527	DIMM_C2 failed test/initialization	Major

Error Code	Error Message	Response
8528	DIMM_C3 failed test/initialization	Major
8529	DIMM_D1 failed test/initialization	Major
852A	DIMM_D2 failed test/initialization	Major
852B	DIMM_D3 failed test/initialization	Major
852C	DIMM_E1 failed test/initialization	Major
852D	DIMM_E2 failed test/initialization	Major
852E	DIMM_E3 failed test/initialization	Major
852F	DIMM_F1 failed test/initialization	Major
8530	DIMM_F2 failed test/initialization	Major
8531	DIMM_F3 failed test/initialization	Major
8532	DIMM_G1 failed test/initialization	Major
8533	DIMM_G2 failed test/initialization	Major
8534	DIMM_G3 failed test/initialization	Major
8535	DIMM_H1 failed test/initialization	Major
8536	DIMM_H2 failed test/initialization	Major
8537	DIMM_H3 failed test/initialization	Major
8538	DIMM_J1 failed test/initialization	Major
8539	DIMM_J2 failed test/initialization	Major
853A	DIMM_J3 failed test/initialization	Major
853B	DIMM_K1 failed test/initialization	Major
853C	DIMM_K2 failed test/initialization	Major
853D	DIMM_K3 failed test/initialization	Major
853E	DIMM_L1 failed test/initialization	Major
853F (Go to 85C0)	DIMM_L2 failed test/initialization	Major
8540	DIMM_A1 disabled	Major
8541	DIMM_A2 disabled	Major
8542	DIMM_A3 disabled	Major
8543	DIMM_B1 disabled	Major
8544	DIMM_B2 disabled	Major
8545	DIMM_B3 disabled	Major
8546	DIMM_C1 disabled	Major
8547	DIMM_C2 disabled	Major
8548	DIMM_C3 disabled	Major
8549	DIMM_D1 disabled	Major
854A	DIMM_D2 disabled	Major
854B	DIMM_D3 disabled	Major
854C	DIMM_E1 disabled	Major
854D	DIMM_E2 disabled	Major
854E	DIMM_E3 disabled	Major
854F	DIMM_F1 disabled	Major
8550	DIMM_F2 disabled	Major
8551	DIMM_F3 disabled	Major
8552	DIMM_G1 disabled	Major

Error Code	Error Message	Response
8553	DIMM_G2 disabled	Major
8554	DIMM_G3 disabled	Major
8555	DIMM_H1 disabled	Major
8556	DIMM_H2 disabled	Major
8557	DIMM_H3 disabled	Major
8558	DIMM_J1 disabled	Major
8559	DIMM_J2 disabled	Major
855A	DIMM_J3 disabled	Major
855B	DIMM_K1 disabled	Major
855C	DIMM_K2 disabled	Major
855D	DIMM_K3 disabled	Major
855E	DIMM_L1 disabled	Major
855F (Go to 85D0)	DIMM_L2 disabled	Major
8560	DIMM_A1 encountered a Serial Presence Detection (SPD) failure	Major
8561	DIMM_A2 encountered a Serial Presence Detection (SPD) failure	Major
8562	DIMM_A3 encountered a Serial Presence Detection (SPD) failure	Major
8563	DIMM_B1 encountered a Serial Presence Detection (SPD) failure	Major
8564	DIMM_B2 encountered a Serial Presence Detection (SPD) failure	Major
8565	DIMM_B3 encountered a Serial Presence Detection (SPD) failure	Major
8566	DIMM_C1 encountered a Serial Presence Detection (SPD) failure	Major
8567	DIMM_C2 encountered a Serial Presence Detection (SPD) failure	Major
8568	DIMM_C3 encountered a Serial Presence Detection (SPD) failure	Major
8569	DIMM_D1 encountered a Serial Presence Detection (SPD) failure	Major
856A	DIMM_D2 encountered a Serial Presence Detection (SPD) failure	Major
856B	DIMM_D3 encountered a Serial Presence Detection (SPD) failure	Major
856C	DIMM_E1 encountered a Serial Presence Detection (SPD) failure	Major
856D	DIMM_E2 encountered a Serial Presence Detection (SPD) failure	Major
856E	DIMM_E3 encountered a Serial Presence Detection (SPD) failure	Major
856F	DIMM_F1 encountered a Serial Presence Detection (SPD) failure	Major
8570	DIMM_F2 encountered a Serial Presence Detection (SPD) failure	Major
8571	DIMM_F3 encountered a Serial Presence Detection (SPD) failure	Major
8572	DIMM_G1 encountered a Serial Presence Detection (SPD) failure	Major
8573	DIMM_G2 encountered a Serial Presence Detection (SPD) failure	Major
8574	DIMM_G3 encountered a Serial Presence Detection (SPD) failure	Major
8575	DIMM_H1 encountered a Serial Presence Detection (SPD) failure	Major
8576	DIMM_H2 encountered a Serial Presence Detection (SPD) failure	Major
8577	DIMM_H3 encountered a Serial Presence Detection (SPD) failure	Major
8578	DIMM_J1 encountered a Serial Presence Detection (SPD) failure	Major
8579	DIMM_J2 encountered a Serial Presence Detection (SPD) failure	Major
857A	DIMM_J3 encountered a Serial Presence Detection (SPD) failure	Major
857B	DIMM_K1 encountered a Serial Presence Detection (SPD) failure	Major
857C	DIMM_K2 encountered a Serial Presence Detection (SPD) failure	Major
857D	DIMM_K3 encountered a Serial Presence Detection (SPD) failure	Major

Error Code	Error Message	Response
857E	DIMM_L1 encountered a Serial Presence Detection (SPD) failure	Major
857F (Go to 85E0)	DIMM_L2 encountered a Serial Presence Detection (SPD) failure	Major
85C0	DIMM_L3 failed test/initialization	Major
85C1	DIMM_M1 failed test/initialization	Major
85C2	DIMM_M2 failed test/initialization	Major
85C3	DIMM_M3 failed test/initialization	Major
85C4	DIMM_N1 failed test/initialization	Major
85C5	DIMM_N2 failed test/initialization	Major
85C6	DIMM_N3 failed test/initialization	Major
85C7	DIMM_P1 failed test/initialization	Major
85C8	DIMM_P2 failed test/initialization	Major
85C9	DIMM_P3 failed test/initialization	Major
85CA	DIMM_R1 failed test/initialization	Major
85CB	DIMM_R2 failed test/initialization	Major
85CC	DIMM_R3 failed test/initialization	Major
85CD	DIMM_T1 failed test/initialization	Major
85CE	DIMM_T2 failed test/initialization	Major
85CF	DIMM_T3 failed test/initialization	Major
85D0	DIMM_L3 disabled	Major
85D1	DIMM_M1 disabled	Major
85D2	DIMM_M2 disabled	Major
85D3	DIMM_M3 disabled	Major
85D4	DIMM_N1 disabled	Major
85D5	DIMM_N2 disabled	Major
85D6	DIMM_N3 disabled	Major
85D7	DIMM_P1 disabled	Major
85D8	DIMM_P2 disabled	Major
85D9	DIMM_P3 disabled	Major
85DA	DIMM_R1 disabled	Major
85DB	DIMM_R2 disabled	Major
85DC	DIMM_R3 disabled	Major
85DD	DIMM_T1 disabled	Major
85DE	DIMM_T2 disabled	Major
85DF	DIMM_T3 disabled	Major
85E0	DIMM_L3 encountered a Serial Presence Detection (SPD) failure	Major
85E1	DIMM_M1 encountered a Serial Presence Detection (SPD) failure	Major
85E2	DIMM_M2 encountered a Serial Presence Detection (SPD) failure	Major
85E3	DIMM_M3 encountered a Serial Presence Detection (SPD) failure	Major
85E4	DIMM_N1 encountered a Serial Presence Detection (SPD) failure	Major
85E5	DIMM_N2 encountered a Serial Presence Detection (SPD) failure	Major
85E6	DIMM_N3 encountered a Serial Presence Detection (SPD) failure	Major
85E7	DIMM_P1 encountered a Serial Presence Detection (SPD) failure	Major
85E8	DIMM_P2 encountered a Serial Presence Detection (SPD) failure	Major

Error Code	Error Message	Response
85E9	DIMM_P3 encountered a Serial Presence Detection (SPD) failure	Major
85EA	DIMM_R1 encountered a Serial Presence Detection (SPD) failure	Major
85EB	DIMM_R2 encountered a Serial Presence Detection (SPD) failure	Major
85EC	DIMM_R3 encountered a Serial Presence Detection (SPD) failure	Major
85ED	DIMM_T1 encountered a Serial Presence Detection (SPD) failure	Major
85EE	DIMM_T2 encountered a Serial Presence Detection (SPD) failure	Major
85EF	DIMM_T3 encountered a Serial Presence Detection (SPD) failure	Major
8604	POST Reclaim of non-critical NVRAM variables	Minor
8605	BIOS Settings are corrupted	Major
8606	NVRAM variable space was corrupted and has been reinitialized	Major
92A3	Serial port component was not detected	Major
92A9	Serial port component encountered a resource conflict error	Major
9505	ATA/ATAPI interface error	Major
A000	TPM device not detected.	Minor
A001	TPM device missing or not responding.	Minor
A002	TPM device failure.	Minor
A003	TPM device failed self test.	Minor
A100	BIOS ACM Error	Major
A421	PCI component encountered a SERR error	Fatal
A5A0	PCI Express component encountered a PERR error	Minor
A5A1	PCI Express component encountered an SERR error	Fatal
A6A0	DXE Boot Services driver: Not enough memory available to shadow a Legacy Option ROM.	Minor

## POST Error Beep Codes

The following table lists POST error beep codes. Prior to system video initialization, the BIOS uses these beep codes to inform users on error conditions. The beep code is followed by a user-visible code on POST Progress LEDs.

**Table 78. POST Error Beep Codes**

Beeps	Error Message	POST Progress Code	Description
1	USB device action	N/A	Short beep sounded whenever USB device is discovered in POST, or inserted or removed during runtime.
1 long	Intel® TXT security violation	0xAE, 0xAF	System halted because Intel® Trusted Execution Technology detected a potential violation of system security.
3	Memory error	Multiple	System halted because a fatal error related to the memory was detected.
<b>The following Beep Codes are sounded during BIOS Recovery.</b>			
2	Recovery started	N/A	Recovery boot has been initiated.
4	Recovery failed	N/A	Recovery has failed. This typically happens so quickly after recovery is initiated that it sounds like a 2-4 beep code.



The following Beep Codes are from the BMC. They are listed here for convenience.			
1-5-2-1	CPU socket population error	N/A	CPU1 socket is empty, or sockets are populated incorrectly – CPU1 must be populated before CPU2.
1-5-2-4	MSID Mismatch	N/A	MSID mismatch occurs if a processor is installed into a system board that has incompatible power capabilities.
1-5-4-2	Power fault	N/A	DC power unexpectedly lost (power good dropout) – Power unit sensors report power unit failure offset.
1-5-4-4	Power control fault	N/A	Power good assertion timeout – Power unit sensors report soft power control failure offset.
1-5-1-2	VR Watchdog Timer	N/A	VR controller DC power on sequence not completed in time.
1-5-1-4	Power Supply Status	N/A	The system does not power on or unexpectedly powers off and a Power Supply Unit (PSU) is present that is an incompatible model with one or more other PSUs in the system.

## USB Device Beeps When POST

Intel® Server Boards of the S2600JF family are designed to indicate USB readiness by a series of beep codes early during POST, just before video becomes available. These four to five beeps mean that the USB is powered and initialized, in order for USB devices such as keyboard and mouse to become operational.

If a USB device such as a pen drive or USB CD/DVD ROM drive is attached to any external USB port, a beep code means that the device is recognized, powered and initialized. Each USB port will issue a beep after an external device is ready for use.

These beep codes do not signal any errors. They are designed to advise the user of USB readiness during POST and while attaching external devices.

This USB Beep is OS independent.

## Glossary

Term	Definition
ACPI	Advanced Configuration and Power Interface
AP	Application Processor
APIC	Advanced Programmable Interrupt Control
ASIC	Application Specific Integrated Circuit
ASMI	Advanced Server Management Interface
BIOS	Basic Input/Output System
BIST	Built-In Self Test
BMC	Baseboard Management Controller
Bridge	Circuitry connecting one computer bus to another, allowing an agent on one to access the other
BSP	Bootstrap Processor
Byte	8-bit quantity.
CBC	Chassis Bridge Controller (A microcontroller connected to one or more other CBCs, together they bridge the IPMB buses of multiple chassis.)
CEK	Common Enabling Kit
CHAP	Challenge Handshake Authentication Protocol
CMOS	In terms of this specification, this describes the PC-AT compatible region of battery-backed 128 bytes of memory, which normally resides on the server board
DPC	Direct Platform Control
EEPROM	Electrically Erasable Programmable Read-Only Memory
EHCI	Enhanced Host Controller Interface
EMP	Emergency Management Port
EPS	External Product Specification
ESB2-E	Enterprise South Bridge 2
FBD	Fully Buffered DIMM
FMB	Flexible Mother Board
FRB	Fault Resilient Booting
FRU	Field Replaceable Unit
FSB	Front Side Bus
GB	1024MB
GPIO	General Purpose I/O
GTL	Gunning Transceiver Logic
HSC	Hot-Swap Controller
Hz	Hertz (1 cycle/second)
I <sup>2</sup> C	Inter-Integrated Circuit Bus
IA	Intel® Architecture
IBF	Input Buffer
ICH	I/O Controller Hub
ICMB	Intelligent Chassis Management Bus
IERR	Internal Error
IFB	I/O and Firmware Bridge
INTR	Interrupt

Term	Definition
IP	Internet Protocol
IPMB	Intelligent Platform Management Bus
IPMI	Intelligent Platform Management Interface
IR	Infrared
ITP	In-Target Probe
KB	1024 bytes
KCS	Keyboard Controller Style
LAN	Local Area Network
LCD	Liquid Crystal Display
LED	Light Emitting Diode
LPC	Low Pin Count
LUN	Logical Unit Number
MAC	Media Access Control
MB	1024KB
MCH	Memory Controller Hub
MD2	Message Digest 2 – Hashing Algorithm
MD5	Message Digest 5 – Hashing Algorithm – Higher Security
ms	milliseconds
MTTR	Memory Type Range Register
Mux	Multiplexor
NIC	Network Interface Controller
NMI	Nonmaskable Interrupt
OBF	Output Buffer
OEM	Original Equipment Manufacturer
Ohm	Unit of electrical resistance
PEF	Platform Event Filtering
PEP	Platform Event Paging
PIA	Platform Information Area (This feature configures the firmware for the platform hardware.)
PLD	Programmable Logic Device
PMI	Platform Management Interrupt
POST	Power-On Self Test
PSMI	Power Supply Management Interface
PWM	Pulse-Width Modulation
RAM	Random Access Memory
RASUM	Reliability, Availability, Serviceability, Usability, and Manageability
RISC	Reduced Instruction Set Computing
RMM3	Remote Management Module – 3 <sup>rd</sup> generation
RMM3 NIC	Remote Management Module – 3 <sup>rd</sup> generation dedicated management NIC
ROM	Read Only Memory
RTC	Real-Time Clock (Component of ICH peripheral chip on the server board.)
SDR	Sensor Data Record
SECC	Single Edge Connector Cartridge
EEPROM	Serial Electrically Erasable Programmable Read-Only Memory

Term	Definition
SEL	System Event Log
SIO	Server Input/Output
SMI	Server Management Interrupt (SMI is the highest priority nonmaskable interrupt.)
SMM	Server Management Mode
SMS	Server Management Software
SNMP	Simple Network Management Protocol
SSI	Server System Infrastructure
TBD	To Be Determined
TIM	Thermal Interface Material
UART	Universal Asynchronous Receiver/Transmitter
UDP	User Datagram Protocol
UHCI	Universal Host Controller Interface
UTC	Universal time coordinate
VID	Voltage Identification
VRD	Voltage Regulator Down
Word	16-bit quantity
ZIF	Zero Insertion Force

## Reference Documents

Refer to the following documents for additional information:

- *Intel® Server Board S2600JF Technical Product Specification (Intel Order Code: G31608)*
- ACPI 3.0: <http://www.acpi.info/spec.htm>
- IPMI 2.0
- *Data Center Management Interface Specification v1.0*, May 1, 2008: [www.intel.com/go/dcmi](http://www.intel.com/go/dcmi)
- *PCI Bus Power Management Interface Specification 1.1*: <http://www.pcisig.com/>
- *PCI Express\* Base Specification Rev 2.0 Dec 06*: <http://www.pcisig.com/>
- *PCI Express\* Card Electromechanical Specification Rev 2.0*: <http://www.pcisig.com/>
- PMBus\*: <http://pmbus.org>
- SATA 2.6: <http://www.sata-io.org/>
- SMBIOS 2.4
- SSI-EEB 3.0: <http://www.ssiforum.org>
- USB 1.1: <http://www.usb.org>
- USB 2.0: <http://www.usb.org>
- Windows\* Logo/SDG 3.0
- *Intel® Dynamic Power Technology Node Manager 1.5 External Interface Specification using IPMI, 2007*. Intel Corporation.
- *Node Power and Thermal Management Architecture Specification v1.5, rev.0.79*. 2007, Intel Corporation.
- *Intel® Server System Integrated Baseboard Management Controller Core External Product Specification, 2007* Intel Corporation.
- *Intel® Thurley Server Platform Services IPMI Commands Specification, 2007*. Intel Corporation.
- *Intel® Server Safety and Regulatory, 2011*. Intel Corporation. (Intel Order Code: G23122)
- *Intelligent Platform Management Bus Communications Protocol Specification, Version 1.0, 1998*. Intel Corporation, Hewlett-Packard\* Company, NEC\* Corporation, Dell\* Computer Corporation.
- *Platform Environmental Control Interface (PECI) Specification, Version 2.0*. Intel Corporation.
- *Platform Management FRU Information Storage Definition, Version 1.0, Revision 1.2, 2002*. Intel Corporation, Hewlett-Packard\* Company, NEC\* Corporation, Dell\* Computer Corporation: <http://developer.intel.com/design/servers/ipmi/spec.htm>.