

Intel® 440MX Chipset For Applied Computing

The Intel® 440MX chipset represents the latest in chipset integration. By providing a cost effective, low power single-component chipset specifically designed to reduce system cost, space and power, this product is ideal for low-power, low cost applied computing platform solutions. The 440MX chipset offers designers an extremely cost effective way to enable Intel quality, reliability, and initiatives across all their low power market segments.

The 440MX chipset supports low power Intel® Celeron™ processor and Intel® Pentium® III processor designs. The 440MX is offered in the small form-factor, 492 Ball Grid Array (BGA) package with a typical power dissipation of 2.1W making it an effective solution for fanless applications.

The 440MX chipset provides advanced features like support for USB, ACPI power management and AC-97 link interface, which enable soft technologies. The chipset is a single-component that integrates the North Bridge and the South Bridge and an additional AC-97 digital link (2 channels) into one chip. It replaces the ISA interface with an 8-bit X-bus that supports KBC, SIO, and Flash memory. Figure 1 illustrates a block diagram of the 440MX platform.

- Lower power small total footprint
- Based on the Intel® 440BX AGPset Core Architecture
- Integrated DRAM controller
- Supports up to 100 MHz SDRAM
- 256 MB maximum memory
- AC'97 Host Controller
- Power Management
- PCI Rev 2.2 Compliant
- 4 PCI Bus Masters
- Integrated IDE Controller for Ultra DMA/33
- Integrated USB Controller
- Low Cost PCI Graphics
- SMBus Interface
- 492 BGA
- 3.3-V core and mixed 3.3V with 5.0-V tolerant and GTL I/O Buffers
- 2.1W (at 100 MHz) and 1.6-W (at 66 MHz) TDP (typical) power dissipation with low-power features enabled

Product Highlights

- Flexible processor support ranging from the Intel Celeron processor – Low Power at 400 MHz to the Pentium III processor – Low Power at 700 MHz and beyond with support for 66 or 100 MHz Processor Side Bus (PSB) speeds
- Offers power management options such as ACPI and Suspend To RAM (STR)
- Supports highly integrated single chipset combining north and south bridges

LINECARD

PRODUCT	PRODUCT CODE	PACKAGE	FEATURES
440MX	FW82443MX100	492 BGA	<ul style="list-style-type: none"> ■ Combines the 440BX AGPset core architecture and PIIX4 south bridge into a single chip ■ Advanced power management features ■ AC-97 link interface based on Intel AC'97 Specification v 2.1 ■ BOM cost savings

440MX

Provides New Level of Integration

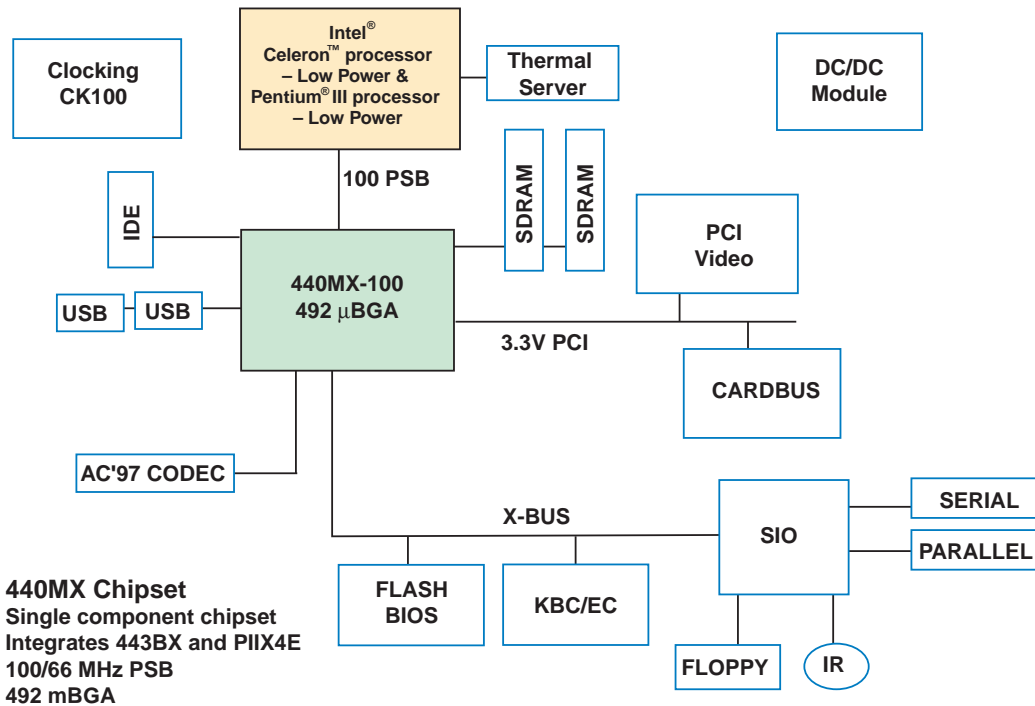

Intel Access

Developer's Site	developer.intel.com
Intel Embedded Chipsets	developer.intel.com/design/chipsets/embedded
Other Intel Support: Intel Literature Center	developer.intel.com/design/litcentr (800) 548-4725 7 a.m. to 7 p.m. CST (U.S. and Canada) International locations please contact your local sales office.
General Information Hotline	(800) 628-8686 or (916) 356-3104 5 a.m. to 5 p.m. PST

Information in this document is provided in connection with Intel products. No license, express or implied, by estoppel or otherwise, to any intellectual property rights is granted by this document. Except as provided in Intel's Terms and Conditions of Sale for such products, Intel assumes no liability whatsoever, and Intel disclaims any express or implied warranty, relating to sale and/or use of Intel products including liability or warranties relating to fitness for a particular purpose, merchantability, or infringement of any patent, copyright or other intellectual property right. Intel products are not intended for use in medical, life saving, or life sustaining applications.

Intel may make changes to specifications and product descriptions at any time, without notice.

Designers must not rely on the absence or characteristics of any features or instructions marked "reserved" or "undefined." Intel reserves these for future definition and shall have no responsibility whatsoever for conflicts or incompatibilities arising from future changes to them.

*Other brands and names are the property of their respective owners.



For more information, visit the Intel Web site at: developer.intel.com

UNITED STATES AND CANADA
Intel Corporation
Robert Noyce Bldg.
2200 Mission College Blvd.
P.O. Box 58119
Santa Clara, CA 95052-8119
USA

EUROPE
Intel Corporation (UK) Ltd.
Pipers Way
Swindon
Wiltshire SN3 1RJ
UK

ASIA-PACIFIC
Intel Semiconductor Ltd.
32/F Two Pacific Place
88 Queensway, Central
Hong Kong, SAR

JAPAN
Intel Kabushiki Kaisha
P.O. Box 115 Tsukuba-gakuen
5-6 Tokodai, Tsukuba-shi
Ibaraki-ken 305
Japan

SOUTH AMERICA
Intel Semicondutores do Brazil
Rue Florida, 1703-2 and CJ22
CEP 04565-001 Sao Paulo-SP
Brazil